

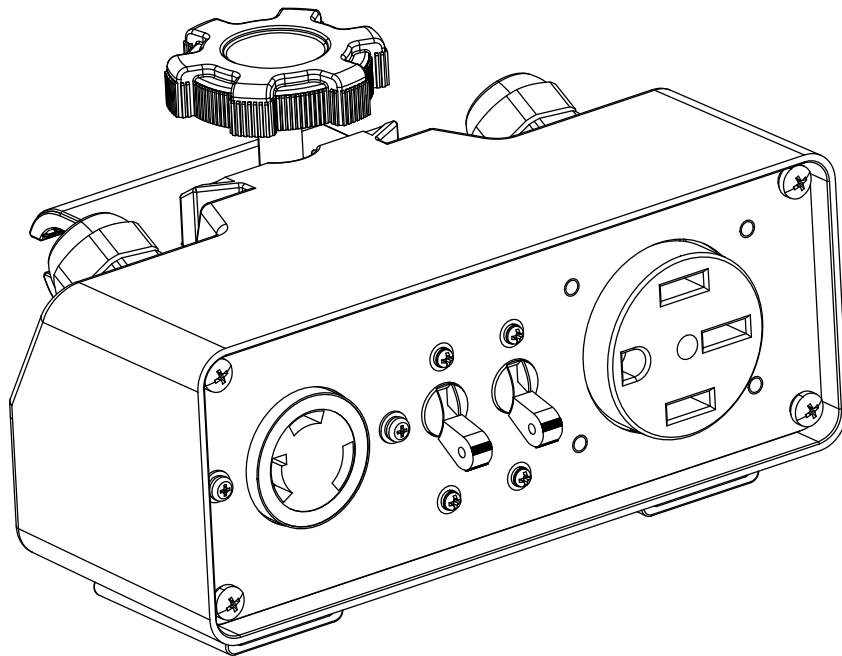

Champion Power Equipment, Inc.

MODEL #201248



PARTS INFORMATION

PARALLEL KIT

SERIAL NUMBER RANGE: ALL



To order replacement parts please visit:
shop.championpowerequipment.com
or call **1-877-338-0999**.

TABLE OF CONTENTS

Parts Diagram **3**

Parts List **4**

Wiring Diagram **5**

PARTS DIAGRAM

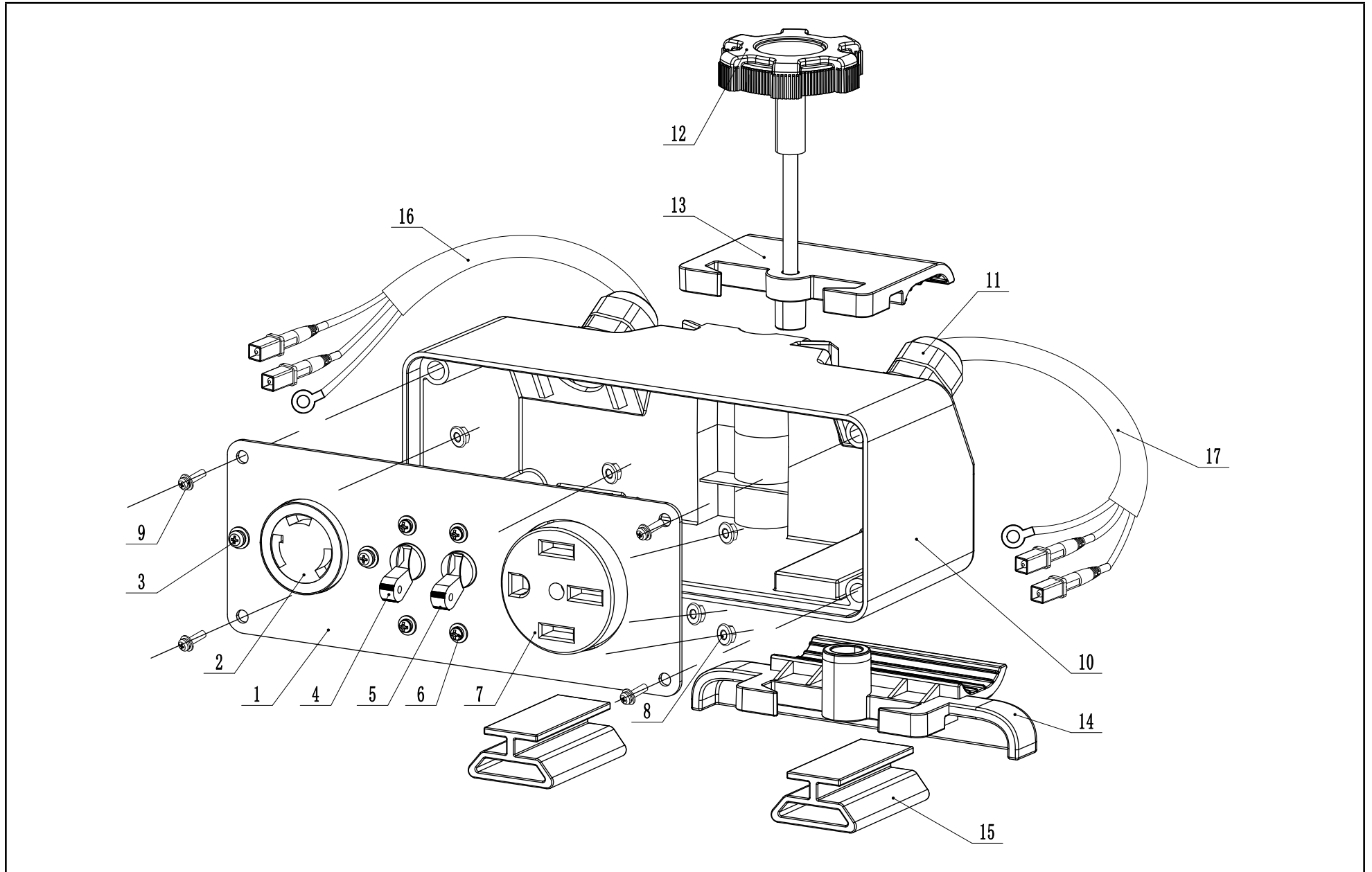

PARTS LIST

#	Part Number	Description	Qty.
1	83.213100.101	Control Panel	1
2	5.1120.073	Receptacle L5-30R, CSA	1
3	1.9074.4.0414.1	Screw/Washer Assembly M4 x 14	2
4	5.1220.930	30Amp Circuit Breaker, Flip Lever, CSA	1
5	5.1220.950	50Amp Circuit Breaker, Flip Lever, CSA	1
6	1.9074.4.0306.1	Screw/Washer Assembly M3 x 6	4
7	5.1120.044	Receptacle 14-50R, CSA	1
8	1.6177.1.04.1	Lock Nut M4, Flange	5
9	1.9074.4.0512.1	Screw/Washer Assembly M5 x 12	4
10	83.213001.31	Control Box	1
11	81.210003.01	Plug, Wire (M25×1.5)	2
12	83.213009.30	Knob Screw	1
13	83.213010.30	Upper Clamp	1
14	83.213011.31	Bottom Clamp	1
15	83.213004.30	Rubber Pad	2
16	5.1900.175	Parallel Wire with Plug, 1800 mm	1
17	5.1900.174	Parallel Wire with Plug, 1000 mm	1

WIRING DIAGRAM

