

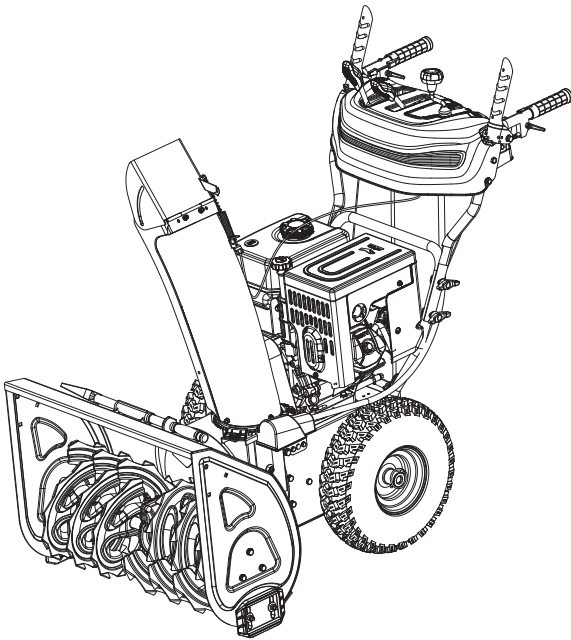

# YARDWORKS<sup>®/MD</sup>

## Snowblower

model number 060-0609-0 | contact us: 1.866.523.5218



**IMPORTANT:** Please read this manual carefully before operating this snowblower and save it for reference.

**⚠ WARNING:** Machine is without engine oil. Properly fill engine oil prior to use to prevent engine damage.

TABLE OF CONTENTS	2
SAFETY INSTRUCTIONS	3
SAFETY SYMBOLS	9
OPERATION SYMBOLS	11
SPECIFICATIONS	13
ASSEMBLY	16
OPERATION	29
CONTROLS	38
MAINTENANCE	44
TROUBLESHOOTING	75
WARRANTY	76



For problems or questions, **DO NOT RETURN TO STORE.**  
Please contact one of our Customer Service Agents  
who would be happy to assist you.



For Customer Assistance Please Call:  
**1.866.523.5218**



## SAFETY DEFINITIONS

The purpose of safety symbols is to attract your attention to possible dangers. The safety symbols, and their explanations, deserve your careful attention and understanding. The safety warnings do not by themselves eliminate any danger. The instructions or warnings they give are not substitutes for proper accident prevention measures.

### **DANGER**

DANGER indicates a hazardous situation which, if not avoided, will result in death or serious injury.

### **WARNING**

WARNING indicates a hazardous situation which, if not avoided, could result in death or serious injury.

### **CAUTION**

CAUTION indicates a hazardous situation which, if not avoided, could result in minor or moderate injury.

### **NOTICE**

NOTICE indicates information considered important, but not hazard-related (e.g., messages relating to property damage).

## GENERAL SAFETY

1. Read the operator's manual carefully. Be thoroughly familiar with the controls and the proper use of the equipment. Know how to stop the unit and disengage the controls quickly.
2. Never allow children under 16 years old to operate the equipment. Never allow adults to operate the equipment without proper instruction.
3. Thrown objects can cause serious injury. Keep the area of operation clear of all persons, particularly small children, and pets. Plan your snow discharge pattern to prevent throwing material toward cars, structures, roads and people.
4. Exercise caution to avoid slipping or falling, especially when operating in reverse.
5. Be aware that the operator or user is responsible for accidents or hazards occurring to other people or their property.
6. Never use the snowblower under the influence of alcohol, medication, or recreational drugs, or if you are tired or ill.

**PREPARATION FOR USE**

1. Disengage all clutch handles before starting the engine.
2. Do not operate the equipment without wearing adequate winter garments. Wear footwear which will improve footing on slippery surfaces.
3. Adjust the auger housing height to clear gravel or crushed rock surface.
4. Never attempt to make any adjustments while the engine is running (except where specifically recommended in the manual).
5. Let engine and machine adjust to outdoor temperatures before starting to clear snow.
6. The operation of any powered machine can result in foreign objects being thrown into the eyes. Always wear safety glasses or eye shields during operation, or while performing an adjustment or repair.
7. Inspect the auger and impeller before starting to ensure that there is no ice buildup.

**⚠ CAUTION:** Thoroughly inspect the area where the equipment is to be used and remove all doormats, sleds, boards, wires, and other foreign objects.

**⚠ CAUTION:** Let engine and machine adjust to outdoor temperatures before starting to clear snow.

## SAFE HANDLING OF GASOLINE

Gasoline is an extremely flammable substance and the vapors are explosive. Serious personal injury can occur when gasoline is spilled on yourself or your clothes, which can ignite. If you come into contact with gasoline, wash affected areas of skin and change clothing immediately.

1. Use only an approved gasoline container.
2. Extinguish all cigarettes, cigars, pipes and other sources of ignition prior to working with or near gasoline.
3. Never refuel machine within closed spaces.
4. Never remove gas cap or add fuel while the engine is hot or running.
5. Allow engine to cool at least two minutes before refueling.
6. Do not over fill fuel tank. Keep fuel level at least ½" (1.27 cm) below bottom of filler neck to provide space for fuel expansion.
7. Replace gasoline cap and tighten securely.
8. If gasoline is spilled, wipe it off the engine and equipment. Move machine to another area. Wait 5 minutes before starting the engine.
9. Never store the machine or fuel container inside where there is an open flame, spark or pilot light (e.g., furnace, water heater, space heater, clothes dryer etc.).
10. Allow machine to cool at least 5 minutes before storing.
11. Never fill containers inside a vehicle or on a truck or trailer bed with a plastic liner. Always place containers on the ground away from your vehicle before filling.
12. If possible, remove gas-powered equipment from the truck or trailer and refuel it on the ground. If this is not possible, then refuel such equipment on a trailer with a portable container, rather than from a gasoline dispenser nozzle.
13. Keep the nozzle in contact with the rim of the fuel tank or container opening at all times until fueling is complete. Do not use gas cans with nozzle lock-open devices.

**⚠ DANGER:** To avoid severe injury or property damage use high levels of care while handling gasoline. Gasoline is an extremely flammable substance and the vapors are explosive. Serious personal injury can occur when gasoline is spilled on yourself or your clothes, which can ignite. If you come into contact with gasoline, wash affected areas of skin and change clothing immediately.

**OPERATING THE SNOWBLOWER**

1. Do not put hands or feet near or under rotating parts. Keep clear of the discharge opening at all times.
2. Exercise extreme caution when operating on or crossing gravel drives, walks, or roads. Stay alert for hidden hazards or traffic.
3. After striking a foreign object, stop the engine, remove the spark plug, thoroughly inspect the snowblower for any damage, and repair the damage before restarting and operating the snowblower.
4. If the unit should start to vibrate abnormally, stop the engine and check immediately for the cause. Vibration is generally a warning of trouble. Vibration typically indicates a mechanical problem has occurred.
5. Stop the engine whenever you leave the operating position, before unclogging the auger housing or discharge guide, and when making any repairs, adjustments, or inspections.
6. Before cleaning, inspecting or repairing any parts of the snowblower ensure the auger has stopped moving. Disconnect the spark plug wire and keep it away from the plug to prevent accidental starting.
7. Before leaving the machine unattended, disengage all control levers, stop the engine and remove the safety key.
8. Do not run the engine indoors. Exhaust fumes are dangerous.
9. Do not clear snow across the face of slopes. Exercise extreme caution when changing direction on slopes. Do not attempt to clear steep slopes.
10. Never operate the snowblower without proper guards, plates or other safety protective devices in place.
11. Never operate the snowblower near glass enclosures, automobiles, window wells, etc., without proper adjustment of the snow discharge angle. Keep children and pets away.
12. Do not overload the machine capacity by attempting to clear snow at too fast a rate.

**⚠ WARNING: Do not put hands or feet near or under rotating parts. Keep clear of the discharge opening at all times.**

**⚠ WARNING: Do not clear snow across the face of slopes. Exercise extreme caution when changing direction on slopes. Do not attempt to clear steep slopes.**

13. Never operate the machine at high transport speeds on slippery surfaces. Use care when reversing.
14. Never direct discharge at bystanders or allow anyone in front of the unit.
15. Disengage power to the impeller when snowblower is transported or not in use.
16. Use only attachments and accessories approved by the manufacturer of snowblower.
17. Never operate the snowblower without good visibility or light. Always be sure of your footing, and keep a firm hold on the handles. Walk; never run.
18. Take all possible precautions when leaving the machine unattended. Stop the engine and remove the safety key.
19. Keep all nuts, bolts and screws tight to be sure the equipment is in safe working condition.
20. Replace worn or damaged parts for safety. Use only genuine replacement parts and accessories.
21. This snowblower is not intended for use by persons (including children) with reduced physical, sensory or mental capabilities, or lack of experience and knowledge, unless they have been given supervision or instruction concerning use of the appliance by a person responsible for their safety.
22. Be careful while working on the machine or clearing a blockage in the auger or impeller to ensure that fingers and hands do not become crushed or cut.
23. Do not touch hot engine components like the muffler, muffler guard or engine block during operation of the snowblower as they will cause burns.
24. Should the unit stop discharging snow for any reason, release the controls to stop and inspect for any lodged items or damaged parts in the auger housing. Reference "Troubleshooting" section for causes and solutions.

**⚠ WARNING: Replace worn or damaged parts for safety. Use only genuine replacement parts and accessories.**

**CLEARING A CLOGGED DISCHARGE CHUTE**

To clear the chute:

- SHUT THE ENGINE OFF!
- Wait 10 seconds to be sure the impeller blades have stopped rotating.
- Always use a clean-out tool. DO NOT use your hands.







**MAINTENANCE AND STORAGE**

- The owner/operator is responsible for all periodic maintenance.
- Complete all scheduled maintenance in a timely manner.
- Correct any issue before operating the snowblower.
- Check shear bolts, engine mounted bolts, etc., at frequent intervals for proper tightness to sure the equipment is in safe, working condition.
- Never store the machine with fuel in the fuel tank inside a building where ignition sources are present such as hot water heaters, space heaters, clothes dryers or any open flame sources. Allow the engine to cool before storing in any enclosure.
- Always refer to owner's guide instructions for important details if the snowblower is to be stored for an extended period.
- Maintain or replace safety and instructions labels, as necessary.
- Run the snowblower for one minute to clear out packed snow and ice to prevent freeze-up during storage.

**⚠ WARNING:** Hand contact with the rotating impeller inside the discharge chute is the most common cause of injury associated with snowblowers. Never use your hand to clean out the discharge chute or auger assembly.

**⚠ WARNING:** Never operate a damaged or defective snowblower.









Some of the following symbols may be used on this product. Please study them and learn their meaning. Proper interpretation of these symbols will allow you to more safely operate the product.

Symbol	Meaning
	<p><b>Read Operator's Manual.</b> To reduce the risk of injury, user must read and understand operator's manual before using this product.</p>
	<p><b>Eye and Ear Protection.</b> Always wear safety goggles or safety glasses with side shields, and as necessary a full face-shield as well as full ear protection when operating this product.</p>
	<p><b>Safety Alert.</b> Precautions that involve your safety.</p>
	<p><b>Risk of Fire/Explosion.</b> Fuel and its vapors are extremely flammable and explosive. Fire can cause severe burns or death. Do not add fuel while the product is operating or still hot.</p> <p><b>Open Flame Alert.</b> Fuel and its vapors are extremely flammable and explosive. Keep fuel away from smoking, open flames, sparks, pilot lights, heat, and other ignition sources.</p>
	<p><b>Electric Shock.</b> Failure to use the starter in dry conditions and to observe safe practices can result in electric shock.</p>
	<p><b>Toxic Fumes.</b> The engine exhaust from this product contains chemicals known to cause cancer and birth defects and other reproductive harm.</p> <p><b>Risk of Asphyxiation.</b> This engine emits carbon monoxide, an odourless, colourless poison gas. Breathing carbon monoxide can cause nausea, fainting or death. Use only in an outdoor well-ventilated area.</p>









Symbol	Meaning
	<p><b>Thrown Objects.</b> This machine may pick up and throw objects which can cause serious personal injury.</p>
	<p><b>Always Use Chute Tool.</b> Never use your hands to clear a clogged chute assembly. Shut OFF engine and remain behind handles until all moving parts have stopped before unclogging.</p>
	<p><b>Hot Surface.</b> To reduce the risk of injury or damage, avoid contact with any hot surface.</p>
	<p><b>Risk of Fire.</b> Fuel and its vapors are extremely flammable and explosive. Fire can cause severe burns or death. Do not add fuel while the product is operating or still hot.</p>
	<p><b>Rotating Auger.</b> DANGER: Avoid injury from rotating auger — keep feet away.</p>
	<p><b>Rotating Blades.</b> Never put your hand in the chute. Contact with rotating parts can amputate fingers and hands.</p>

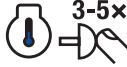

Some of the following symbols may be used on this product. Please study them and learn their meaning. Proper interpretation of these symbols will allow you to more safely operate the product.

Symbol	Meaning
	<b>Check Oil Level.</b> Recommended oil is 0W-30. The engine can be seriously damaged without oil. Always check the oil level before using. The machine must be resting firmly on level ground when checking.
	<b>Check Fuel Level.</b> Use clean, fresh, regular unleaded gasoline with a minimum octane rating of 87 and an ethanol content of less than 10% by volume.
	<b>Minimum Octane.</b> Use clean, fresh, regular unleaded gasoline with a minimum octane rating of 87 and an ethanol content of less than 10% by volume.
	<b>Fuel Valve: ON.</b> Move the fuel valve lever to the on position.
	<b>Fuel Valve: OFF.</b> Move the fuel valve lever to the OFF position.
	<b>Choke: ON.</b> To start a cold engine, move the choke lever to the choke position.
	<b>Choke: OFF.</b> When the engine starts, move the choke to run position.
	<b>Throttle: Full Speed.</b> Move the throttle lever to full speed to start the engine.
	<b>Throttle: Low Speed.</b> Lowers the speed of the engine.

**OPERATION SYMBOLS**

Symbol	Meaning
	<p><b>Insert Engine Key.</b> Make sure the engine safety key is inserted into the key hole.</p>
	<p><b>Cold Prime.</b> To start a cold engine, prime 3-5 times.</p>
	<p><b>Warm Prime.</b> To start a warm engine, DO NOT prime.</p>
	<p><b>Recoil Start.</b> Pull the recoil starter grip to start manually.</p>
	<p><b>Remove Engine Key.</b> Remove the engine key.</p>
	<p><b>Engine Start.</b> To use the electric start feature, see this Operator's manual for further instructions.</p>
	<p><b>Engine Stop.</b></p>
	<p><b>Gasoline Tank: Full</b></p>
	<p><b>Gasoline Tank: Empty</b></p>

**SNOWBLOWER**

<b>Stages</b>	2
<b>Speed Control</b>	6 forward/2 reverse
<b>Clearing Width</b>	27" (68.6 cm)
<b>Clearing Depth</b>	21" (53.3 cm)
<b>Impeller Diameter</b>	12" (30.5 cm)
<b>Auger Diameter</b>	12" (30.5 cm)
<b>Tire Diameter</b>	15" (38 cm)

**ENGINE**

<b>Brand</b>	Champion Power Equipment
<b>Displacement</b>	301 cc
<b>Engine Model</b>	R300S
<b>Start Type</b>	Electric, Recoil

**OIL**

<b>Oil Capacity</b>	37.2 fl. oz. (1.1 L)
<b>Oil Type</b>	0W-30

**FUEL**

Use clean, fresh, regular unleaded gasoline with a minimum octane rating of 87 and an ethanol content of less than 10% by volume.

<b>Fuel Capacity</b>	1.53 gal. (5.8 L)
----------------------	-------------------

**SPARK PLUGS**

<b>OEM Spark Plug</b>	F6RTC
<b>Replacement Spark Plug</b>	NGK BPR6ES or equivalent
<b>Make certain the spark plug gap is 0.028 – 0.031" (0.7 – 0.8 mm).</b>	

**BELTS**

<b>OEM Auger Belt</b>	Gates Truflex G 5LXA925 (Kevlar) = (L × W × H = 925 × 16.6 × 8.2 mm)
<b>OEM Drive Belt</b>	Gates HTD Timing 5M-825-15 (L × W = 825 × 15 / Pitch = 5 mm)

**SNOWBLOWER**

- A. Self-drive Control Lever
- B. Speed Control Lever
- C. Discharge Chute Deflector Lever
- D. Shear Pin Storage
- E. Discharge Chute Rotation Lever
- F. Grip Heat Warmer Switch
- G. Auger Control Lever
- H. Clean-out Tool
- I. Control Panel
- J. Handle Locking Knobs
- K. Discharge Chute Deflector
- L. Discharge Chute
- M. Auger
- N. Shave Plate
- O. Skid Shoes
- P. Auger Housing
- Q. Wheels
- R. Lower Handle
- S. Upper Handle
- T. Lights

**ENGINE**

- A. Key (Safety Lock Out)
- B. Primer Bulb
- C. Throttle Lever
- D. Choke Lever
- E. Fuel Valve (On/Off)
- F. Fuel Cap
- G. Electric Start Button
- H. Recoil Starter Grip
- I. Oil Fill and Level Check Cap
- J. Oil Drain Plug
- K. Fuel Level Gauge

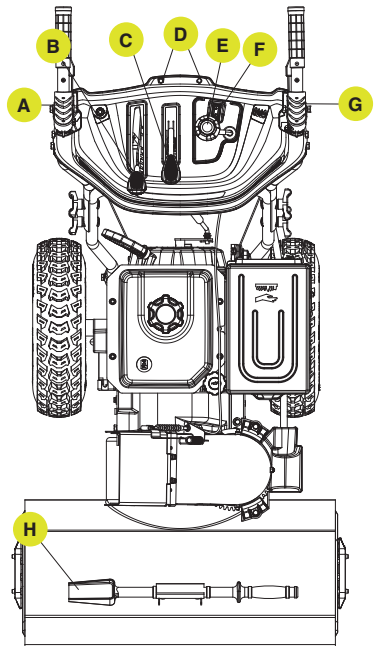

**SPECIFICATIONS**

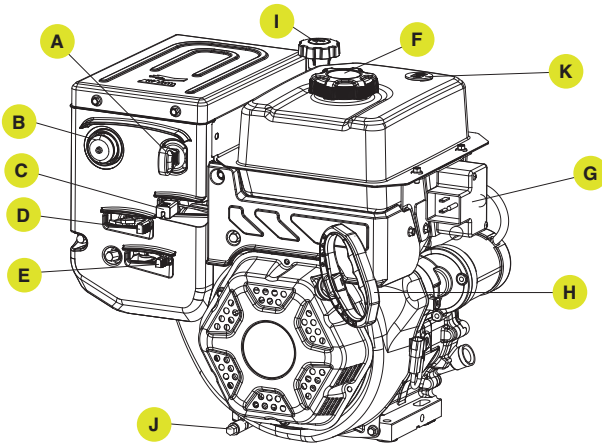
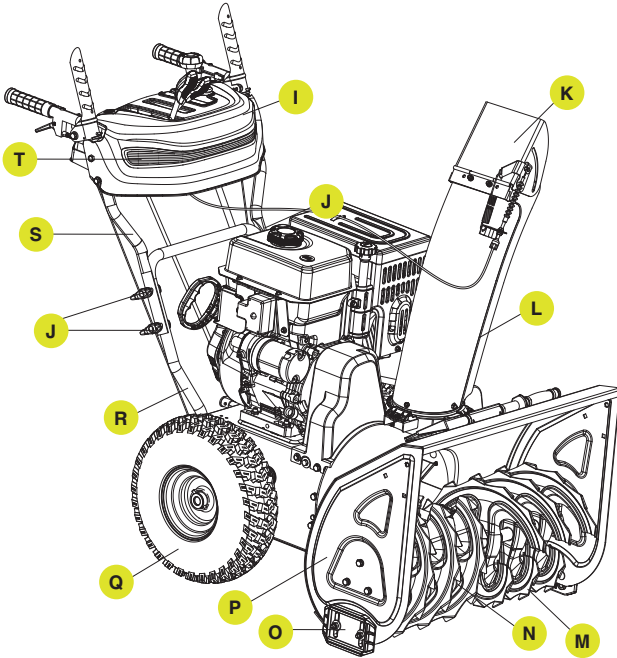

**UNPACKING**

1. Set the shipping carton on a solid, flat surface.
2. Remove everything loose from the carton.
3. Cut down the bottom carton to allow a flat surface area to install the assembly parts without scratching parts or cutting tires.
4. Now you are ready for assembly.

**TOOLS INCLUDED**











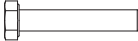

Part	Part Qty.	Bag A
Wrench (10/13)	1	Yes

**ADDITIONAL PARTS**

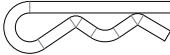
Part	Part Qty.	Bag A	Preassembled
Shear Pins	4+2	4	2 on the panel
Clip (for auger)	4+2	4	2 on the panel
Starter Electric Cord	1	No	No
Engine Oil	1	Yes	No

model no. 060-0609-0 | contact us: 1.866.523.5218

**ASSEMBLY PARTS**

Part	Part Qty.	Description	Hardware Qty.	Hardware Reference	Tool(s) Needed
Lower Handle	1	M8 × 20 bolt	2		13 mm wrench
		ø8 Flat Washer	2		N/A
		M8 × 45 bolt	2		13 mm wrench
		Curve washer	2		N/A
Upper Handle	1	M8×50 bolt	4		N/A
		Curved washer	4		N/A
		Locking knob	4		N/A
Speed Control Lever	1	Clip (pre-assembled)	2		N/A
		ø8 Flat Washer (preassembled)	2		N/A
Discharge Chute	1	Bolt M6x12	3		N/A
		ø6 Washer	3		N/A
		M6 Lock Nut	3		10 mm wrench
Chute Cable	1	(preassembled on chute end)			
Chute Deflector Cable	1	M6 Nut (preassembled)	2		10 mm wrench

**ASSEMBLY**

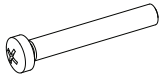
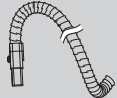
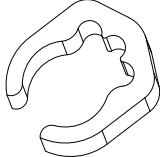
Steering Trigger	2	M5 × 35 screw	2		Cross or Phillips-Head screwdriver
Wire Harness	1	(preassembled on engine and panel end)			
Cable Clamp	4	(preassembled)			



## REMOVE THE WHEELS

To make the lower handle easier to assemble, remove the wheels from both sides. For each wheel, locate the pin (A) holding the wheel on. Lift the ring (B) around the axle (C) and then pull the pin (A) out holding the wheel on (Fig.1). Repeat on the other side. Remove the wheels and carefully place the snowblower on the ground.

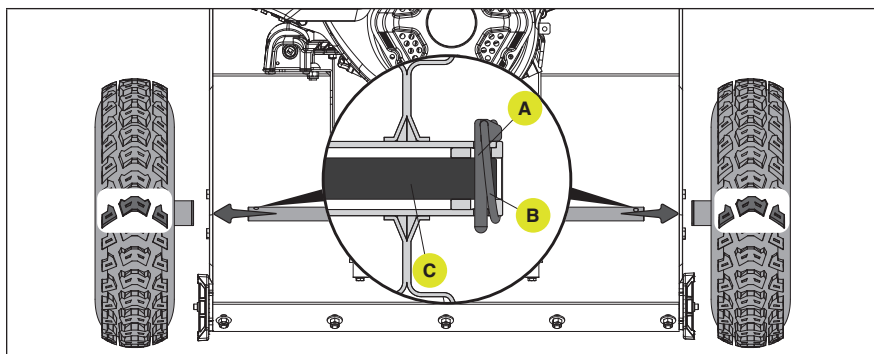

Figure 1

## HANDLE

1. Attach the lower handle (A) onto the unit body with 2 bolts (B), and 2 curved rectangular washers (C) for the top holes and then 2 bolts (D), and 2 flat washers (E) for the bottom holes using included tool or your own 13 mm wrench (Fig. 2). Torque until snug. Do not overtighten.

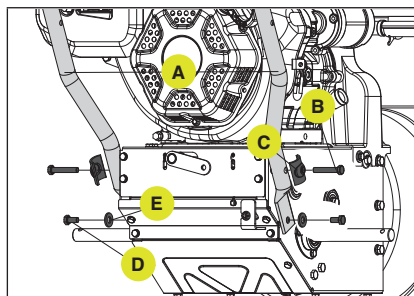

Figure 2

2. Connect the upper and lower handle with bolts (F), washers (G) and locking knobs (H) (Fig. 3). Torque until snug. Do not overtighten.

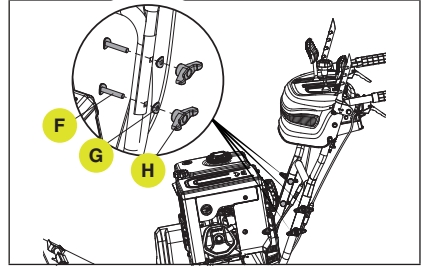

Figure 3

### INSTALL THE WHEELS

Slide the wheel (A) onto axle (B). Tread pattern should face forward. Place axle pin (C) into wheel. The axle has a center hole to attach the wheel to the axle (which connects to the drive train). Once inserted, fold ring (D) around axle to hold in place (Fig. 4).

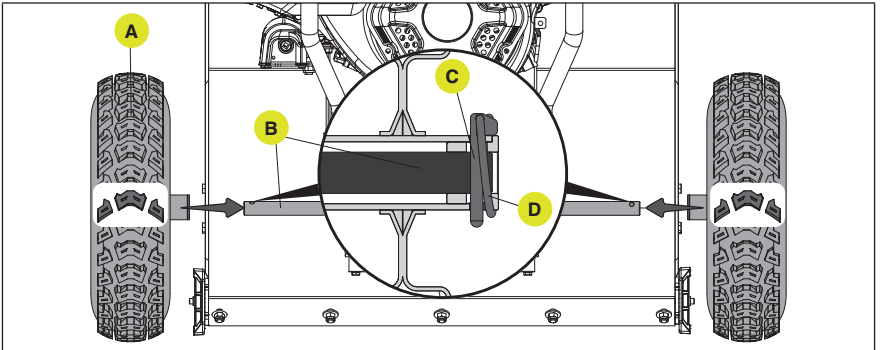

Figure 4

### SPEED CONTROL CONNECTING LEVER

1. Attach the connecting lever (A) and connecting base with clip under the panel. Remove the washer and clip, insert as shown into the connecting base, then install the washer (B) and clip (C). Make sure the spring (D) is loaded on the correct side. (Fig. 3)
2. Connect the other end of the connecting lever (A) and speed adjusting handle with clip on the base. Remove the washer and clip, insert as shown into the connecting base, then install the washer (B) and clip (C). Make sure the spring (D) is loaded on the correct side. (Fig. 5)

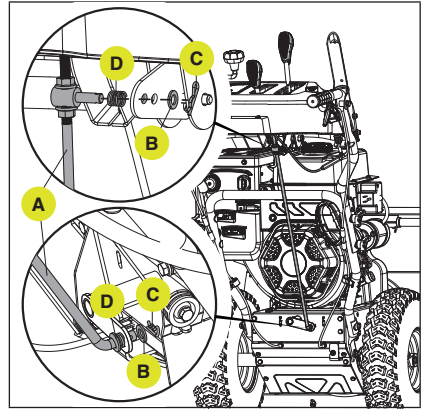

Figure 5

### CHUTE

Remove the chute (A) from the bubble wrap and attach it to the chute gear (B). Connect the chute with 3 bolts (C), 3 washers (D) and 3 locking nuts (E) as shown (Fig. 6). Torque until snug. Do not overtighten.

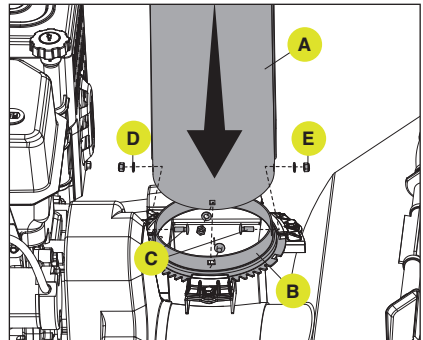

Figure 6

### CHUTE CABLE

Locate the thick chute cable (A) zip tied to the lower handle and connect under the panel. Make sure this cable is routed underneath the lower handle as shown before assembly to the control panel. Align center, insert, then tighten cap (B) clockwise until snug. (Fig. 7)

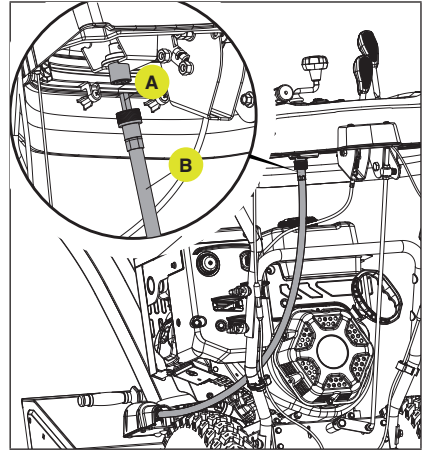

Figure 7

### DISCHARGE CHUTE DEFLECTOR CABLE

Locate the coiled chute deflector cable (A) and uncoil. Open the chute deflector completely by hand then install the cylindrical end (B) of the cable as shown, ensuring that the chute deflector adjustment handle is at the last or highest position, and then press the chute deflector to hang the cable threaded head into the hole by placing the nut on the top side shown by the arrow (C), then adjust the bottom nut (D) into position to tighten the cable. (Fig. 8)

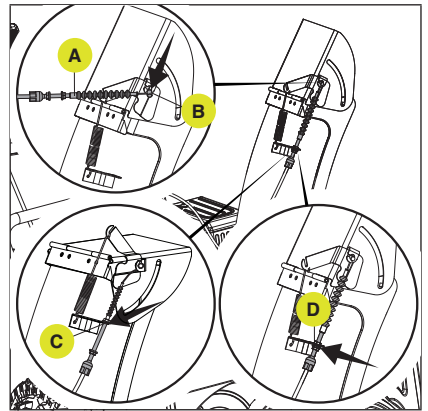

Figure 8

model no. 060-0609-0 | contact us: 1.866.523.5218

### WIRE HARNESS

Locate engine and panel wire harness. Connect the wire harness by aligning the plug from the panel (A) with the engine harness (B). The harness will make an audible “click.” Press the lock in (the red arrow), then perform a pull test to confirm locked together. (Fig. 9)

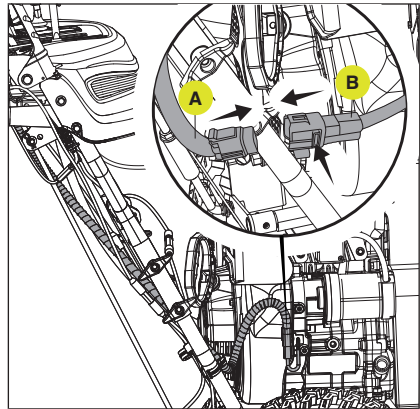

Figure 9

### TRIGGER STEERING SYSTEM

Attached both left and right triggers to their respective handles as shown. Connect each trigger with a screw (A) (Fig. 10). Torque until snug. Do not overtighten.

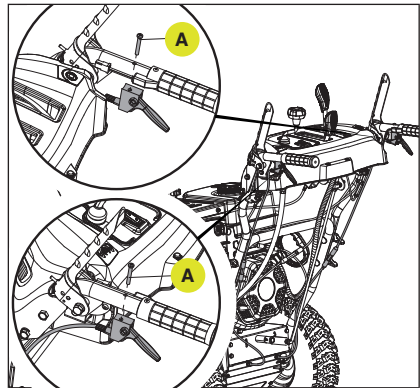

Figure 10

**CABLE CLAMPS**

Connect the cable clamps (A) to the handle bars as shown. If already connected, move into the correct location, and remove to position the cables and then reconnect to the handle bars as shown. Make sure the cables aren't pinched. (Fig. 11 and 12)

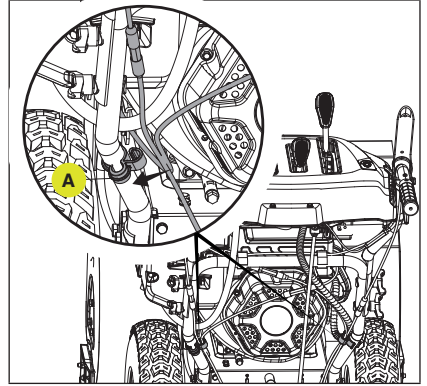

Figure 11

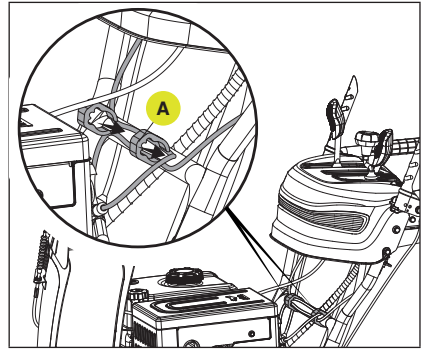

Figure 12

## CHECK/ADD ENGINE OIL

Capacity of engine oil: 16.9 fl. oz. (0.5 L)

Use 0W-30, but in some cases, depending on weather, 5W-30 will work. See chart for oil type recommendations.

Weather will affect engine oil and engine performance. Change the type of engine oil used based on weather conditions to suit the engine needs.

Synthetic oil may be used after the 5-hour initial break-in period. Using synthetic oil does not decrease the recommended oil change interval.

1. Check the oil with engine stopped and level.
2. Remove the oil cap/dipstick (A) and wipe it clean. (Fig. 13)

Recommended Engine Oil Type				
← 0W-30 / 5W-30				
°F	-20	0	20	40
°C	-28.9	-17.8	-6.7	4.4
Ambient temperature				

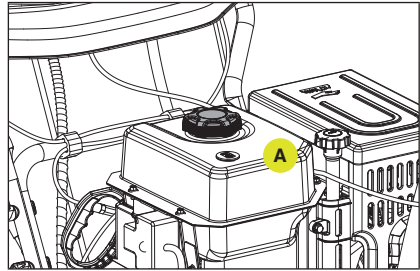

Figure 13

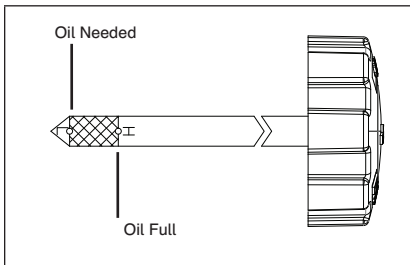

Figure 14

3. Insert the oil cap/dipstick into the oil filler neck but do not screw it in, then remove it to check the oil level.
4. If the oil level is near or below the lower limit mark on the dipstick, remove the oil cap/dipstick, and fill with the recommended oil to the upper limit mark. Do not overfill. (Fig. 14)
5. Reinstall the oil cap/dipstick.

**⚠ WARNING:** Machine is shipped without engine oil, properly fill engine oil prior to use to prevent engine damage.

## ADD FUEL

Fuel tank capacity: 0.7 gal. (2.6 L)

Use clean, fresh, regular unleaded gasoline with a minimum octane rating of 87 and an ethanol content of less than 10% by volume.

1. Remove the fuel tank cap (A).  
(Fig. 15)

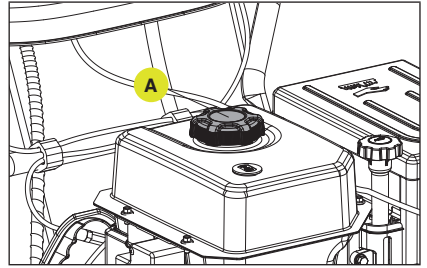

Figure 15

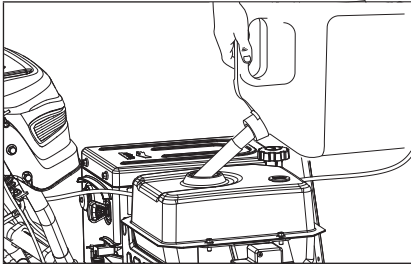

Figure 16

2. Add fuel to the bottom of the fuel level limit in the neck of the fuel tank.  
Do not overfill. Wipe up spilled fuel before starting the snowblower.  
(Fig. 16)

3. The approximate fuel level is shown on the fuel gauge on top of the fuel tank.  
(Fig. 17)

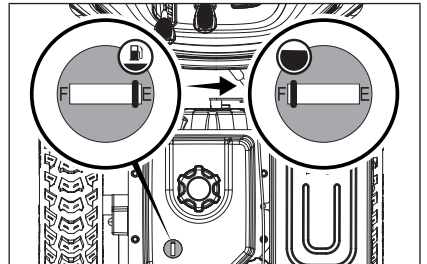

Figure 17



### SAFE HANDLING OF GASOLINE

Gasoline is an extremely flammable substance and the vapors are explosive. Serious personal injury can occur when gasoline is spilled on yourself or your clothes, which can ignite. If you come into contact with gasoline, wash affected areas of skin and change clothing immediately.

1. Use only an approved gasoline container.
2. Extinguish all cigarettes, cigars, pipes and other sources of ignition prior to working with or near gasoline.
3. Never refuel machine within closed spaces.
4. Never remove gas cap or add fuel while the engine is hot or running.
5. Allow engine to cool at least two minutes before refueling.
6. Do not over fill fuel tank. Keep fuel level at least ½" (1.27 cm) below bottom of filler neck to provide space for fuel expansion.
7. Replace gasoline cap and tighten securely.
8. If gasoline is spilled, wipe it off the engine and equipment. Move machine to another area. Wait 5 minutes before starting the engine.

**⚠ DANGER:** To avoid severe injury or property damage use high levels of care while handling gasoline. Gasoline is an extremely flammable substance and the vapors are explosive. Serious personal injury can occur when gasoline is spilled on yourself or your clothes, which can ignite. If you come into contact with gasoline, wash affected areas of skin and change clothing immediately.

**⚠ WARNING:** Gasoline is highly flammable and explosive, and you can be burned or seriously injured when refueling.

- Stop engine and keep heat, sparks, and flame away.
- Refuel only outdoors.
- Gasoline is poisonous, be careful not to touch or breathe in the vapor.

9. Never store the machine or fuel container inside where there is an open flame, spark or pilot light (e.g., furnace, water heater, space heater, clothes dryer etc.).
10. Allow machine to cool at least 5 minutes before storing.
11. Never fill containers inside a vehicle or on a truck or trailer bed with a plastic liner. Always place containers on the ground away from your vehicle before filling.
12. If possible, remove gas-powered equipment from the truck or trailer and refuel it on the ground. If this is not possible, then refuel such equipment on a trailer with a portable container, rather than from a gasoline dispenser nozzle.
13. Keep the nozzle in contact with the rim of the fuel tank or container opening at all times until fueling is complete. Do not use gas cans with nozzle lock-open devices.

## GENERAL SAFETY

1. Read the operator's manual carefully. Be thoroughly familiar with the controls and the proper use of the equipment. Know how to stop the unit and disengage the controls quickly.
2. Never allow children under 16 years old to operate the equipment. Never allow adults to operate the equipment without proper instruction.
3. Thrown objects can cause serious injury. Keep the area of operation clear of all persons, particularly small children, and pets. Plan your snow discharge pattern to prevent throwing material toward cars, structures, roads and people.
4. Exercise caution to avoid slipping or falling, especially when operating in reverse.
5. Be aware that the operator or user is responsible for accidents or hazards occurring to other people or their property.
6. Never use the snowblower under the influence of alcohol, medication, or recreational drugs, or if you are tired or ill.

## PREPARATION FOR USE

1. Disengage all clutch handles before starting the engine.
2. Do not operate the equipment without wearing adequate winter garments. Wear footwear which will improve footing on slippery surfaces.
3. Adjust the auger housing height to clear gravel or crushed rock surface.
4. Never attempt to make any adjustments while the engine is running (except where specifically recommended in the manual).
5. Let engine and machine adjust to outdoor temperatures before starting to clear snow.
6. The operation of any powered machine can result in foreign objects being thrown into the eyes. Always wear safety glasses or eye shields during operation, or while performing an adjustment or repair.
7. Inspect the auger and impeller before starting to ensure that there is no ice buildup.

**⚠ WARNING:** Read the operator's manual carefully. Be thoroughly familiar with the controls and the proper use of the equipment. Know how to stop the unit and disengage the controls quickly.

**⚠ WARNING:** Thoroughly inspect the area where the equipment is to be used and remove all doormats, sleds, boards, wires, and other foreign objects.

**OPERATING THE SNOWBLOWER**

1. Do not put hands or feet near or under rotating parts. Keep clear of the discharge opening at all times.
2. Exercise extreme caution when operating on or crossing gravel drives, walks, or roads. Stay alert for hidden hazards or traffic.
3. After striking a foreign object, stop the engine, remove the spark plug, thoroughly inspect the snowblower for any damage, and repair the damage before restarting and operating the snowblower.
4. If the unit should start to vibrate abnormally, stop the engine and check immediately for the cause. Vibration is generally a warning of trouble. Vibration typically indicates a mechanical problem has occurred.
5. Stop the engine whenever you leave the operating position, before unclogging the auger housing or discharge guide, and when making any repairs, adjustments, or inspections.
6. Before cleaning, inspecting or repairing any parts of the snowblower ensure the auger has stopped moving. Disconnect the spark plug wire and keep it away from the plug to prevent accidental starting.
7. Before leaving the machine unattended, disengage all control levers, stop the engine and remove the safety key.
8. Do not run the engine indoors. Exhaust fumes are dangerous.
9. Do not clear snow across the face of slopes. Exercise extreme caution when changing direction on slopes. Do not attempt to clear steep slopes.
10. Never operate the snowblower without proper guards, plates or other safety protective devices in place.
11. Never operate the snowblower near glass enclosures, automobiles, window wells, etc., without proper adjustment of the snow discharge angle. Keep children and pets away.
12. Do not overload the machine capacity by attempting to clear snow at too fast a rate.
13. Never operate the machine at high transport speeds on slippery surfaces. Use care when reversing.
14. Never direct discharge at bystanders or allow anyone in front of the unit.
15. Disengage power to the impeller when snowblower is transported or not in use.
16. Use only attachments and accessories approved by the manufacturer of snowblower.

**⚠ WARNING: Never operate a damaged or defective snowblower.**

17. Never operate the snowblower without good visibility or light. Always be sure of your footing, and keep a firm hold on the handles. Walk; never run.
18. Take all possible precautions when leaving the machine unattended. Stop the engine and remove the safety key.
19. Keep all nuts, bolts and screws tight to be sure the equipment is in safe working condition.
20. Replace worn or damaged parts for safety. Use only genuine replacement parts and accessories.
21. This snowblower is not intended for use by persons (including children) with reduced physical, sensory or mental capabilities, or lack of experience and knowledge, unless they have been given supervision or instruction concerning use of the appliance by a person responsible for their safety.
22. Be careful while working on the machine or clearing a blockage in the auger or impeller to ensure that fingers and hands do not become crushed or cut.
23. Do not touch hot engine components like the muffler, muffler guard or engine block during operation of the snowblower as they will cause burns.
24. Should the unit stop discharging snow for any reason, release the controls to stop and inspect for any lodged items or damaged parts in the auger housing. Reference "Troubleshooting" section for causes and solutions.

## COMMON SITUATIONS WHILE OPERATING

### CLEARING A CLOGGED DISCHARGE CHUTE

Hand contact with the rotating impeller inside the discharge chute is the most common cause of injury associated with snowblowers. Never use your hand to clean out the discharge chute or auger assembly.

To clear the chute:

1. **SHUT THE ENGINE OFF!**
2. Wait 10 seconds to be sure the impeller blades have stopped rotating.
3. Always use a clean-out tool. **DO NOT** use your hands.

 **WARNING:** Never operate a damaged or defective snowblower.

## BEFORE OPERATION

### CHECK THE GENERAL CONDITION AND MAKE REPAIRS:

- Look around and underneath the engine for signs of oil or gasoline leaks.
- Remove any excessive dirt or debris, especially around the muffler and recoil starter.
- Look for signs of damage.
- Check that all shields and covers are in place, and all nuts, bolts, and screws are tightened.

### CHECK THE ENGINE:

1. There is no fuel or oil in the engine. Fill with fuel and add 0W-30 prior to first use.
2. Check the fuel level (see ADD FUEL section).
3. Check the oil level (see CHECK/ADD OIL section).

## OPERATING SUGGESTIONS

### PREPARING FOR SNOW REMOVAL

**IMPORTANT!** Before the first snowfall, the area in which snow removal is to take place should be cleared of all door mats, stones, sticks, etc., which might be picked up by the auger and damage the snow thrower. Any obstacles should be marked to prevent the auger from being driven into them.

To become familiar with the controls and machine, operate the snow thrower in a clear area before removing snow. The more familiar you become with the snow thrower the better results you will have in its use.

**⚠ WARNING:** If snow clogs the discharge chute do not try to remove it before:

- Releasing the auger control handle.
- Stopping the engine.
- Disconnecting the cable from the spark plug.

Do not put your hand inside the chute or auger. Use the chute clearing tool included with your snowblower.

A light coat of wax may be applied to the inside surface of the auger housing, discharge chute and deflector to prevent snow and ice from sticking. Be certain all controls are disengaged, and engine is not running.

Allow 2 to 4 minutes of engine warm-up time before starting snow removal.

The best results are obtained when snow is removed as soon as possible after it falls, and before it is packed down by driving or walking on snow.

### SNOW CONDITIONS

Snow removal conditions vary so greatly from the first fluffy snowfall to the heavy wet snow that operating instructions must be flexible to fit the type of snow removal encountered. The operator must adapt the operation of the snow thrower to depth of snow, wind direction, temperature, and snow conditions.

### OPERATING TIPS

1. Pay attention to your body to avoid over exertion and to avoid frost bite. Take breaks indoors to rest & warm up.
2. Whenever possible discharge snow downwind.
3. Do not attempt to remove ice or hard packed frozen snow.
4. Always overlap each pass slightly to assure complete snow removal.
5. Remove snow one auger width beyond the pavement, to provide area for wind-blown drifts to form to keep your pavement drift-free.

**NOTICE:** The engine can be seriously damaged without oil. Always check the oil level before using. The machine must stand on level ground when checking.

Engine key may be attached to the recoil starter grip. Please remove the key from the recoil starter grip and attach/install properly.

**WARNING:** Never start the engine until all the above measures under assembly have been carried out.

- Never use the snowblower without first reading and understanding the instructions and all the warning and instruction stickers on the machine.
- Always use protective goggles or a visor during use, maintenance and service.

6. Remove snow one auger width beyond street edge by 20-33 feet (6-10 meters) to the snowplow approach side of your driveway entrance. This will give an area for the snowplow exit flow to spill off, which will keep the entrance to your driveway free of a snowplow ridge.
7. Remove snow from around your mailbox to prevent the snow exiting the snowplow from pushing your mailbox over.
8. Be considerate. Watch your throwing distance and direction to avoid blowing snow on your neighbor's house or driveway, and the street.

### OPERATING SPEED

When throwing snow, it is important that the auger and impeller are kept at a maximum speed for the best results. This is accomplished by having the throttle control set at fast (Rabbit position). Ground speed is controlled by selecting 1, 2, 3, 4, 5 or 6 with the self-drive speed control lever.

Operate in position 1 or 2 (low speed) for heavy snow removal.

Operate in position 3 or 4 (medium speed) for moderate snow removal.

Operate in position 5 or 6 (high speed) for light snow removal and transport.

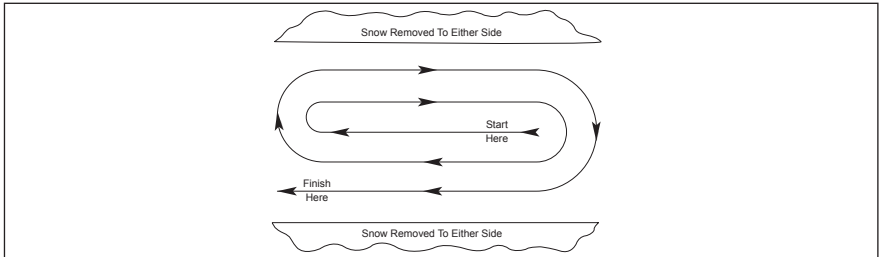

Figure 18

A definite pattern of operation is required to thoroughly clean the snow area. This pattern will avoid a second removal of snow and will avoid throwing snow in unwanted places. Where it is possible to throw snow to the right and left, as on a long driveway, it is advantageous to start in the middle. Plow from one end to the opposite end throwing snow to both sides without changing direction of the discharge chute (Fig.18).



If snow can only be thrown to one side of the driveway or sidewalk, start at one end on the far side. At the end of the first pass, rotate the discharge chute 180° for the return pass. At the end of each succeeding pass, rotate the discharge chute 180° to maintain direction of throw in the same area (Fig. 19).

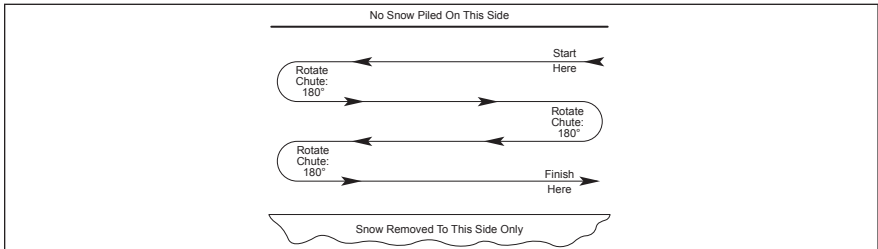

Figure 19

## OPERATION AT HIGH ALTITUDE

The density of air at high altitude is lower than at sea level. Engine power is reduced as the air mass and air-fuel ratio decrease. Engine power will be reduced approximately 3 ½% for every 1000' (304 m) of elevation above sea level. This is a natural trend and cannot be changed by adjusting the engine. At high altitudes increased exhaust emissions can also result due to the increased enrichment of the air fuel ratio. Other high altitude issues can include hard starting, increased fuel consumption and spark plug fouling. To alleviate high altitude issues other than the natural power loss, we can provide a high altitude carburetor main jet at an additional cost.

The part number and recommended minimum altitude for the application of the high altitude carburetor main jet is listed in the following table. In order to select the correct high altitude main jet, it is necessary to identify the carburetor model. For this purpose, a code is stamped on the side of the carburetor. Select the correct high altitude jet part number corresponding to the carburetor code found on your particular carburetor.

Carburetor Code	Main Jet	Jet Part Number	Altitude
16100-Z0S0210-R9A1	Main Jet	16161-Z151910-00A1	
	High Altitude	16161-Z151710-00A1	914-1828 m (3000-6000')
	High Altitude	16161-Z151510-00A2	1828-2438 m (6000-8000')

## STARTING THE ENGINE

1. Make sure the engine key (safety lock out) (A) is inserted into the keyhole.
2. To start a cold engine: (Fig. 20)
  - 2a. Move the throttle lever (B) to full speed.
  - 2b. Move the choke lever (C) to the choke position.
  - 2c. Move the fuel shut-off lever (D) to the ON position.
  - 2d. Prime (E) 3-5 times.
  - 2e. Move the choke lever (C) to the run position once the engine begins to run after you pull the recoil start grip or use the electric start.

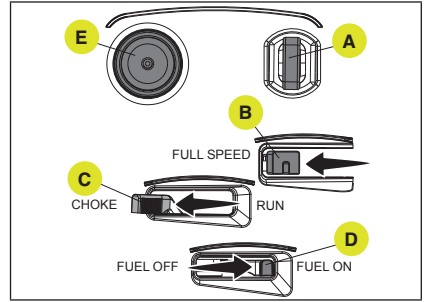

Figure 20

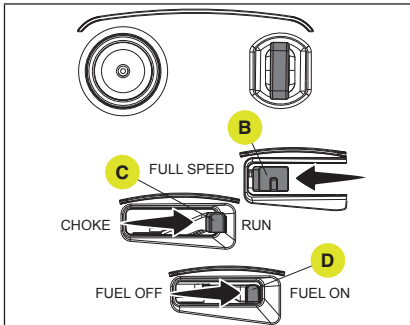

Figure 21

3. To start a warm engine: (Fig. 21)
  - 3a. Move the throttle lever (B) to full speed.
  - 3b. Move the choke lever (C) to the run position.
  - 3c. Move the fuel shut-off lever (D) to the ON position.
  - 3d. Do not prime.

- Stand back and to the right of the unit, pull the starter grip lightly until you feel resistance then pull briskly. Return the starter grip gently. (Fig. 22)

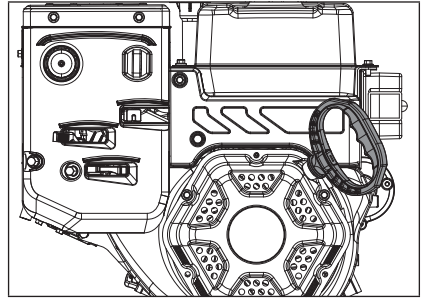

Figure 22

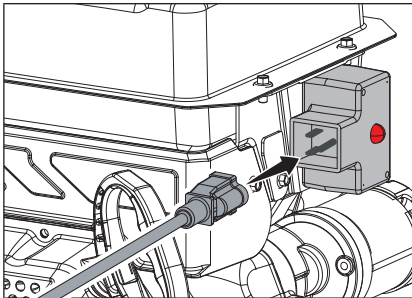

Figure 23

- Alternatively, for electric start, plug in the supplied electrical cord into the starter. Press the electric start button and make sure that the main supply voltage is 120 V~ 60 Hz. (Fig. 23)

## STOPPING THE ENGINE

To stop the engine after finished blowing, turn the fuel valve off and let the carburetor run out of fuel until the engine stops. This is the best way to stop the engine before putting the snowblower away to prevent fuel from sitting in the carburetor. Fuel left in the carburetor will go bad and create gum that will clog the carburetor jets.

To quickly stop the engine, such as in an emergency, remove the engine key (safety lock out) from the keyhole.

**⚠ CAUTION:** To prevent damaging the electric starter, do not run it more than 10 times at intervals of 5 seconds on, then 5 seconds off. If the engine does not start after this series of attempts, allow the starter to cool for at least 40 minutes before trying to start it again. If the engine still does not start, contact customer service center for assistance 1.866.523.5218. Once started, disconnect the plug from the power supply and the starter.

**SELF-DRIVE CONTROL LEVER**

Located on the right-side (from behind the snowblower). (Fig. 24)

When the snowblower has been put into gear, pushing this lever towards the handle engages the wheels.

Releasing the self-drive control lever causes the machine to stop moving.

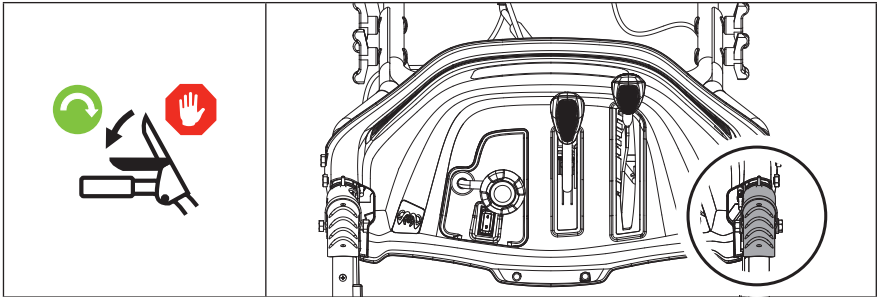

Figure 24

**SPEED CONTROL LEVER**

Forward speeds range from slowest position 1 to fastest position 6.

Reverse speeds range from slowest position R1 to fastest position R2. (Fig. 25)

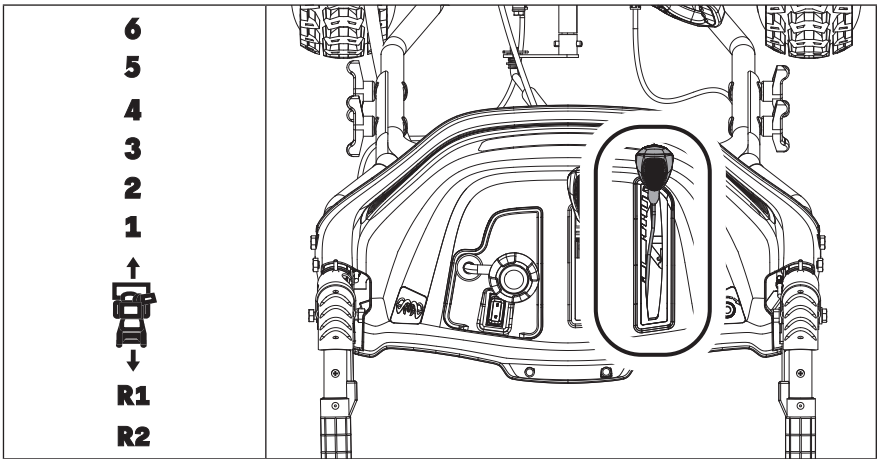

Figure 25

### AUGER CONTROL LEVER

Located on the left-side (from behind the snowblower). (Fig. 26)

Pushing this lever towards the handle causes the auger and impeller to activate.

Releasing the auger control lever causes the auger to stop moving.

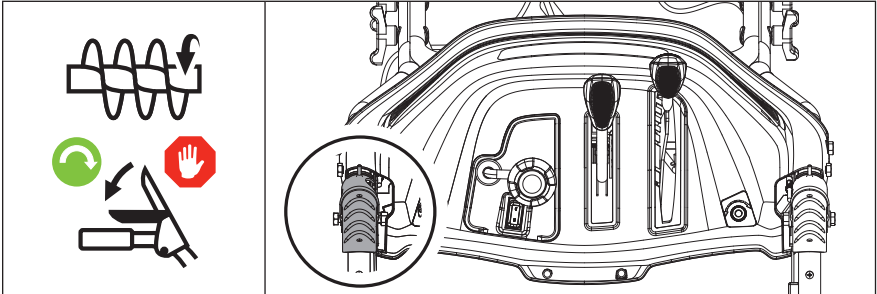

Figure 26

### DISCHARGE HEIGHT LEVER

The discharge chute deflector lever controls the deflector up or down. Pull the lever back toward the operator to tip the deflector up. Push the lever forward to tip the deflector down.

(Fig. 27)

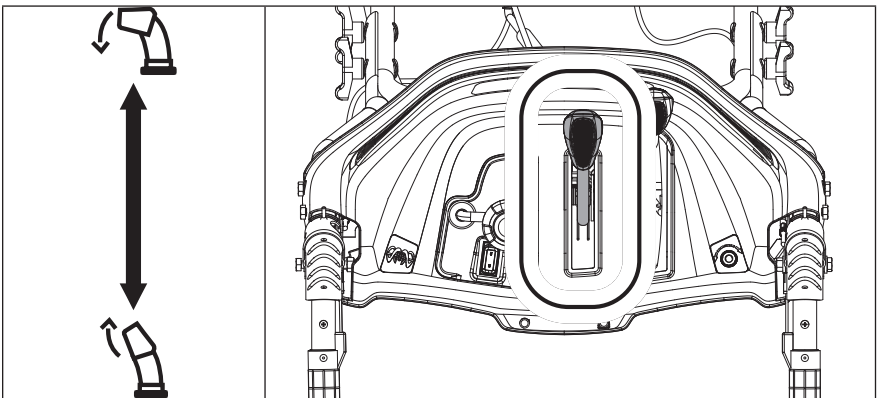

Figure 27

**DISCHARGE DIRECTION CRANK**

Move the discharge chute rotation crank either left or right. Clockwise (CW) moves the chute to the right. Counterclockwise (CCW) moves the chute to the left. (Fig. 28)

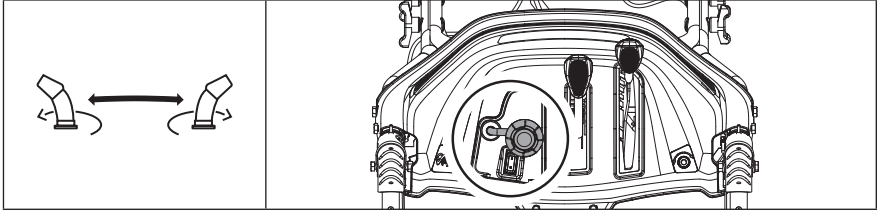

Figure 28

**TRIGGER STEERING SYSTEM**

This model is equipped with a dual trigger steering feature. A small trigger under each hand grip controls the steering of the machine.

1. Engage the self-drive control lever (A) to move the machine forward. (Fig. 29)
2. Pull up on the left trigger (B), to turn left.
3. Release the left trigger, to continue straight.
4. Pull up on the right trigger (C), to turn right.
5. Release the right trigger, to continue straight.

6. Disengage self-drive control lever (A), then pull both triggers to make a tight 180° turn or push back to the garage.

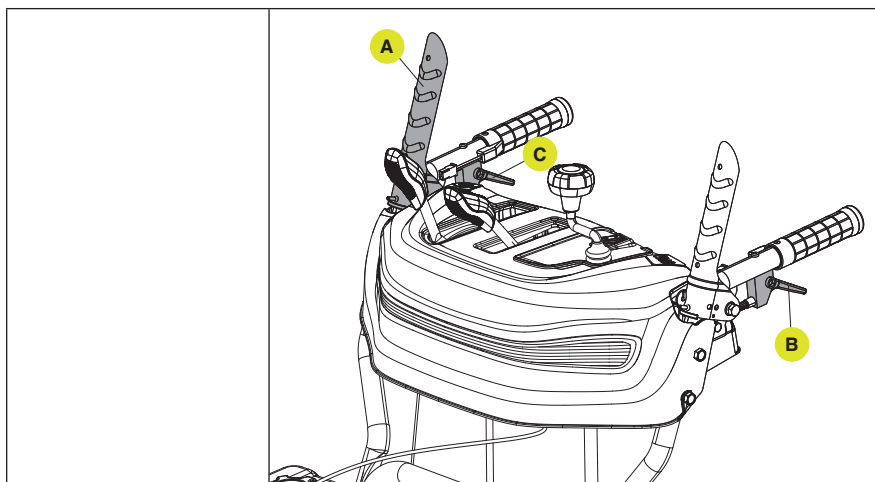

Figure 29

### CLUTCH LOCK FEATURE

This snowblower offers a clutch lock feature that will enable the operator to keep the snowblower moving forward while you adjust the chute. To use the clutch lock system, follow the following steps.

- While both the drive and auger control levers are fully depressed, release the auger control lever (A) while keeping the self-drive control lever (B) fully depressed. The clutch lock feature will automatically keep the auger control lever engaged as long as the self-drive control lever is depressed. (Fig. 30)

**⚠ WARNING:** If snow clogs the discharge chute do not try to remove it before:

- Releasing the auger control handle.
- Stopping the engine.
- Disconnecting the cable from the spark plug.

Do not put your hand inside the chute or auger. Use the chute clearing tool included with your snowblower.

- This allows the operator to keep driving the snowblower while they now use their left hand to make any adjustments to the discharge chute needed to maximize operation. To disengage the clutch lock feature simply release the self-drive control lever.

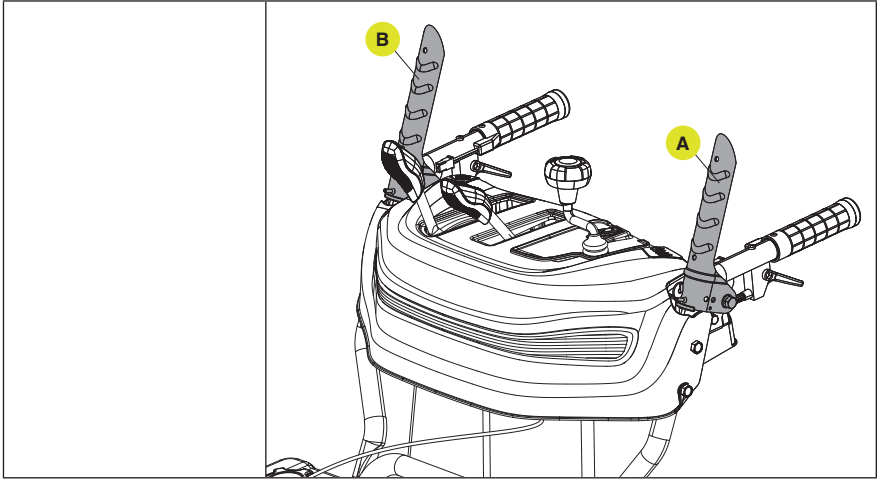

Figure 30

### HEATED HAND GRIPS

Turn on the grip warmer switch to activate the heated hand grips. (Fig. 31)

Turn off the grip warmer switch before stopping the snowblower.

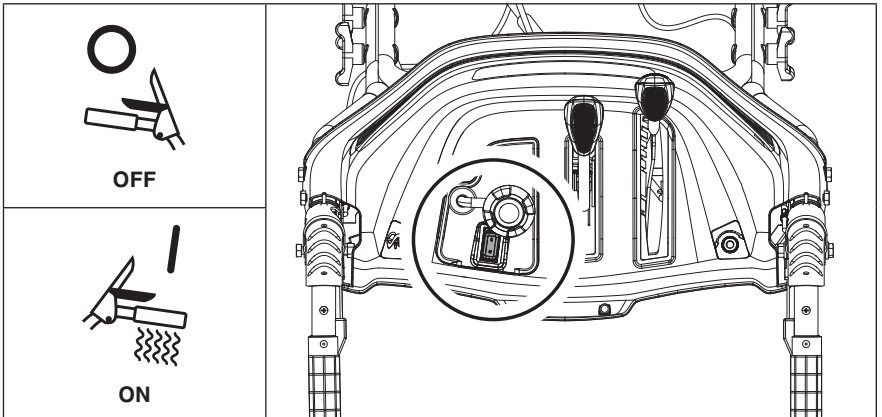

Figure 31



**LIGHTS**

The lights on the control panel turn on automatically when the engine is started.

The lights on the control panel turn off automatically when the engine is stopped.

### ADJUST THE SKID SHOES

- Tilt the snowblower auger back and place a spacer under the shave plate below the augers that is the height that you want the shave plate to ride above the ground.
- Loosen the bolts holding the skid shoes in place and slide the skid shoes down until they contacts the ground.
- Re-tighten the skid shoe bolts.

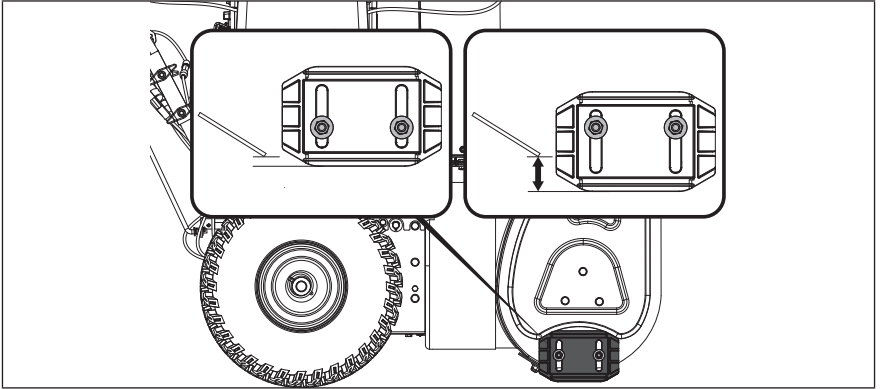

Figure 32

### OIL CHANGE

Drain the engine oil when the engine is warm. Warm oil drains quickly and completely.

1. Turn the fuel valve lever to the OFF position to reduce the possibility of fuel spillage.
2. Place a suitable container below the snowblower to catch the used oil.

model no. 060-0609-0 | contact us: 1.866.523.5218

3. Remove the drain bolt and drain the oil into the container by slightly tipping the engine to tilt the oil drain downward. (Fig. 33)

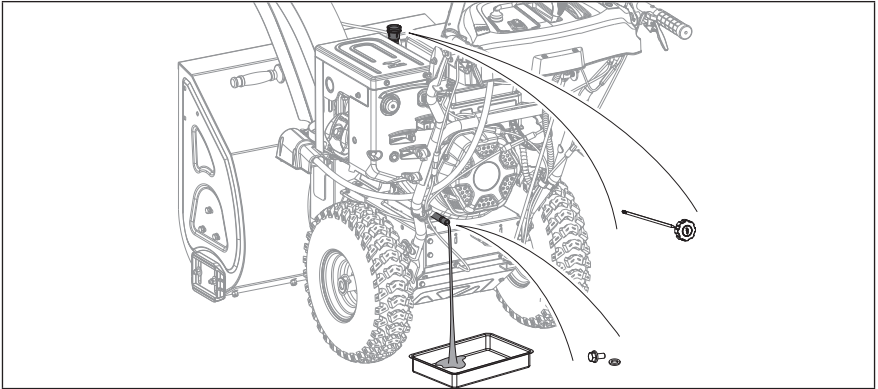

Figure 33

4. Replace the drain bolt. Tighten until snug.
5. With the engine in a level position, fill to the upper limit mark on the dipstick with the recommended oil (0W-30). (Fig. 34)

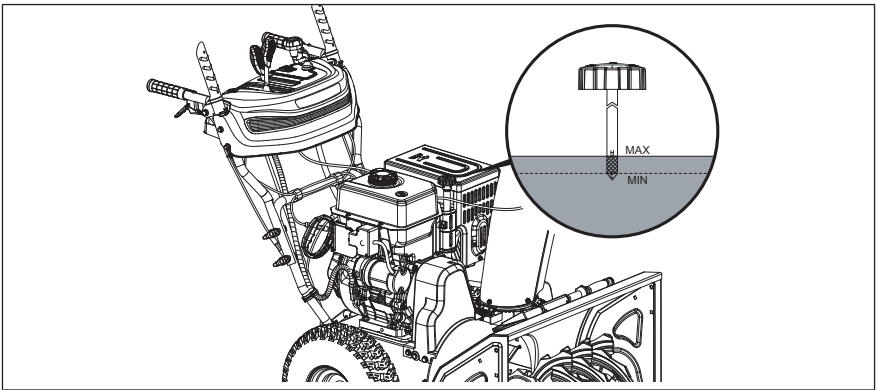

Figure 34

6. Reinstall the oil cap/dipstick securely.

## REPLACING SHEAR PINS

1. The augers are secured to the spiral shaft with shear pins and clips. If the auger should strike a foreign object or ice jam, the snowblower is designed so that the pins shear. (Fig. 35)

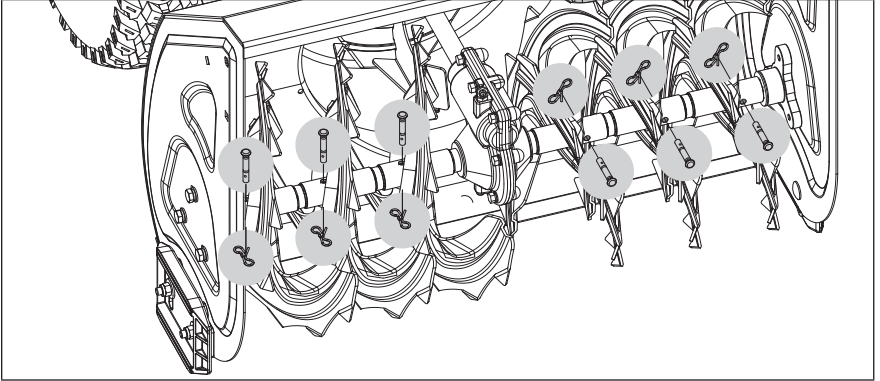

Figure 35

2. If the augers will not turn, check to see if the pins have sheared. Replacement shear pins and clips are found on the control panel and the manual bag. (Fig. 36)

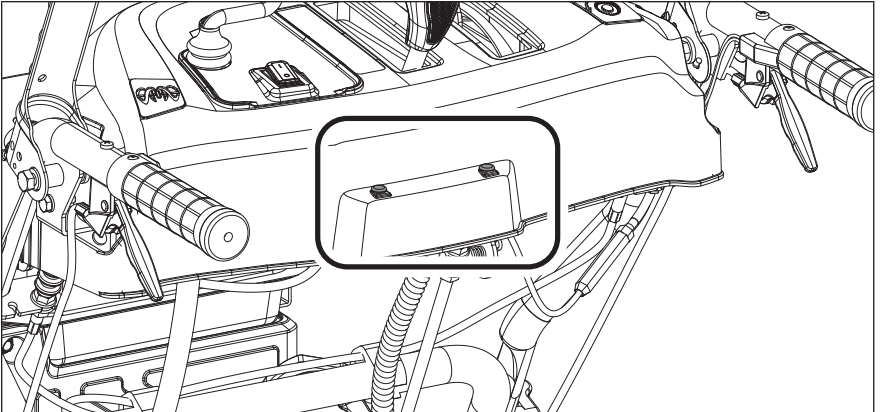

Figure 36

3. Tap out broken shear pin with a hammer and punch or M6 bolt.
4. Apply anti seize lubricant to replacement shear pin to prevent corrosion and to make pin easy to remove in future.
5. Install replacement shear pin through hole in auger and hole in auger shaft.
6. Install clip through hole at end of shear pin.

## ADJUST SELF-DRIVE CONTROL HANDLE CABLE

The cables are preset by the factory. Proper tension is important because you will want your snowblower to move forward properly in heavy snowfalls. You will want to perform this test when temperatures are above freezing before snow season sets in. There are 2 levels of tension in the control handles. It is best to run this test while the engine is on. Shut down the engine once you're ready to make any adjustments. (Fig. 37)

Stage 1 there is no tension, the transmission is disengaged.

Stage 2 there is tension, the transmission is engaged.

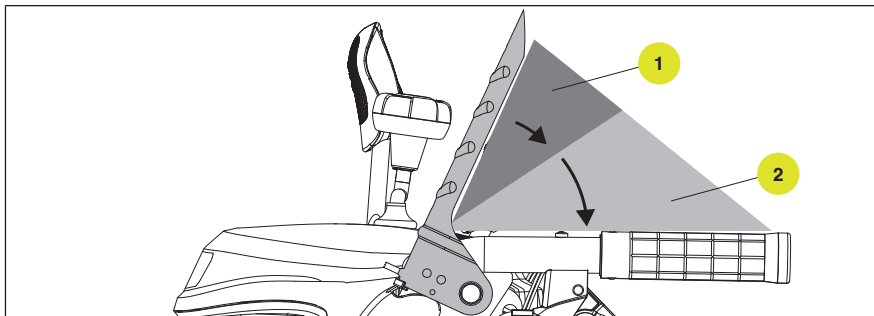

Figure 37

If there is no stage 2, the friction disc is near end of life.

Stage 1 increases slightly during long-term usage. If stage 1 is most of the control handle movement, the wheels will not rotate properly. Make adjustments as follows.

Tighten the cable and reduce the length of stage 1 to approximately what is shown above visually. Do not reduce the length of stage 1 to almost none, there will be a risk of no disengagement. Slide rubber boot back, loosen the nut (A) counterclockwise, then loosen the center bolt (B) clockwise. Test function. Tighten the nut clockwise against the long sleeve bolt. Slide rubber boot back to cover the nut. (Fig. 38)

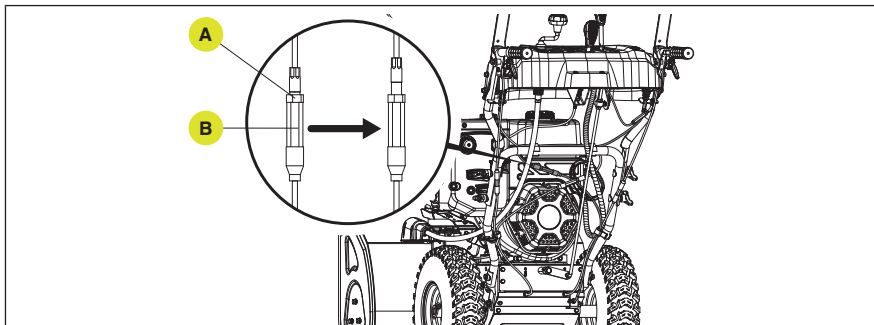

Figure 38

If the snowblower fails to drive with the drive control engaged and performing the drive control cable adjustment fails to correct the problem, the friction disc may need to be replaced. See 'Repair or Replace Friction Disc'.

If the friction disc is ok, then you should replace the cable.

If you find the wheel drives when the handle is not pressed, or when you press the handle and the wheels do not drive or rotate, the cable is most likely frozen. You should replace the cable or wait until it thaws out to test.

### ADJUST SPEED CONTROL LEVER

Make sure all fluids are removed and spark plug is disconnected.

Tools required:

- 13 mm wrench

To adjust your snowblower's speed control, proceed as follows:

1. Locate the speed control rod (A) connected to the connecting lever base (B). Disassemble the speed control rod from the connecting lever base. (Fig. 39)

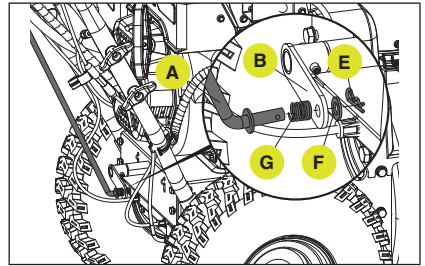

Figure 39

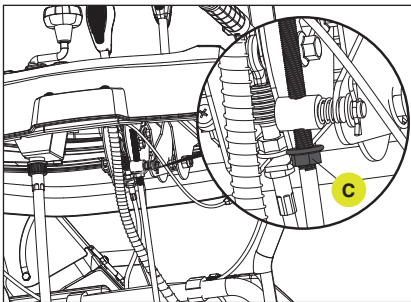

Figure 40

2. Below the panel, loosen the nut (C) counterclockwise. (Fig. 40)

3. Rotate the speed control rod (D) upwards to increase forward speed and decrease reverse speed. Alternatively, rotate the speed control rod downwards to decrease forward speed and increase reverse speed. (Fig. 41)

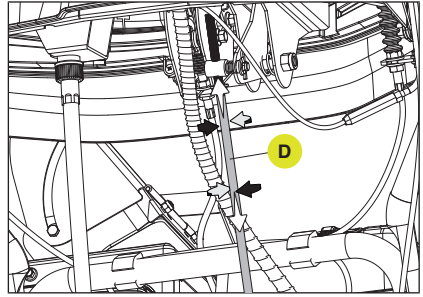

Figure 41

4. Reinstall connecting lever rod to the connecting lever base then install the clip (E) and washer (F). Make sure the spring (G) is loaded on the correct side as shown earlier. (Fig. 39)
5. Perform a speed test to confirm everything is in working order.
6. Tighten the nut from earlier (C).

### ADJUST AUGER CONTROL CABLE

Proper tension is important because you will want your snowblower to maximize belt life in heavy snowfalls. The belt tension controlled by the auger cable is preset by the factory. During regular usage, the auger belt will lose tension over time and need to be adjusted. If you notice your auger is not engaging, follow these steps to correct performance.

1. Locate the auger control cable, connected to the auger control lever on the left side (from behind the snowblower). (Fig. 42)

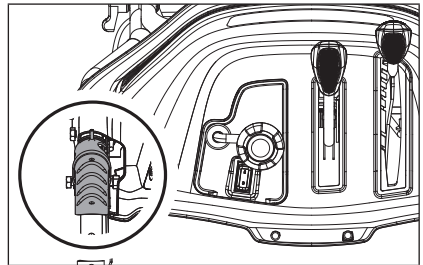

Figure 42

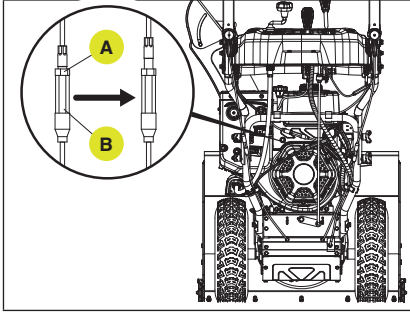

Figure 43

- MAINTENANCE**
- Slide rubber boot back, loosen the nut (A) counterclockwise, then loosen the center bolt (B) clockwise. Test function. Tighten the nut clockwise against the long sleeve bolt. Slide rubber boot back to cover the nut. Lengthening this nut connection will create more tension with the auger belt. Do not over adjust the cable, too much tension on belt will not allow the belt to separate from the pulley when disengaging. If the belt isn't allowed to disengage properly, you could cause premature wearing of the belt and ultimately cause belt failure. (Fig. 43)
  - With a helper, operate the auger control on and off with the control lever, and make sure the auger visually isn't turning when released (Your helper would need to be a safe distance to help you determine if the adjustments are working. They will need to view the auger or impeller rotation while you press down or release the control lever). If when released, there is a slightly turning of the auger, make slight adjustments to fine tune performance to stop the rotation when released, but working when pressed down.



model no. 060-0609-0 | contact us: 1.866.523.5218

### ADJUST DISCHARGE CHUTE DEFLECTOR CABLES

Make sure all fluid are removed and spark plug is disconnected.

Tools required:

- 10 mm wrench

To adjust the chute deflector cable, when it does not open fully or does not tip down enough, proceed as follows:

1. Locate the chute deflector control lever on the control panel. (Fig. 44)

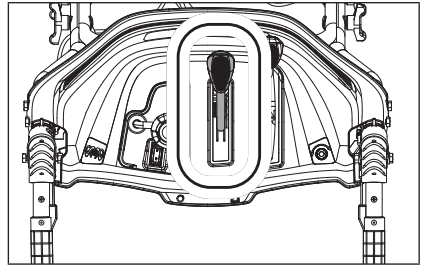

Figure 44

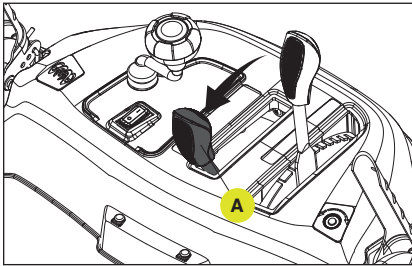

Figure 45

2. Move the chute deflector lever (A) all the way back to move the deflector to the highest, near vertical position. (Fig. 45)

3. On the chute deflector control cable, slide back the rubber boot and loosen the two nuts (B), one each side of the bracket as shown. (Fig. 46)

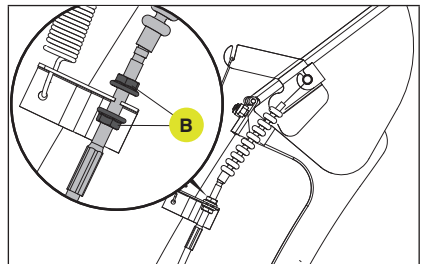

Figure 46

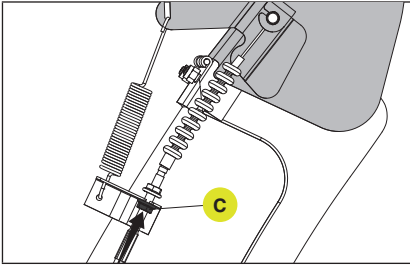

Figure 47

4. Rotate the lower nut (C) clockwise to move the nut upwards toward the bracket to remove cable slack. Stop turning the nut when you feel the cable is engaged against the return spring, and just before the deflector starts moving down. If the deflector moves down a bit, then turn the lower nut counterclockwise away from the bracket to engage the spring, without moving the deflector downwards. (Fig. 47)

5. Rotate the upper nut (D) clockwise to move the nut downwards against the bracket. Tighten these two nuts until snug. (Fig. 48)
6. Slide the rubber boot back to cover the end of the cable sheath.
7. Test the deflector to verify that you have full travel, from near vertical to fully down.

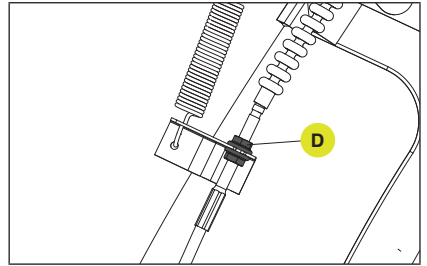

Figure 48

### ADJUST CHUTE DEFLECTOR TENSION

- 10 mm wrench
  - 13 mm wrench
1. Locate M8 lock nut (A) under the panel on the pivot of the chute deflector lever.
  2. Locate the head of the M8 bolt (B) on the right side of the lever for the M8 lock nut. (Fig. 49)

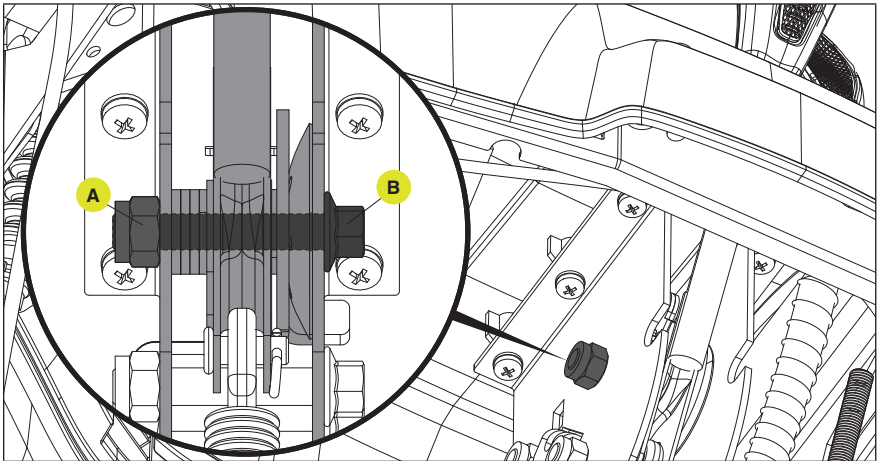

Figure 49

3. To increase deflector tension to prevent unwanted deflector movement from heavy snow, use a 10 mm wrench on the head of the bolt and a 13 mm wrench to tighten the M8 lock nut.
4. To decrease deflector tension to make deflector move easier, use a 10 mm wrench on the head of the bolt and use a 13 mm wrench to loosen the M8 lock nut.

## REPLACE SELF-DRIVE CONTROL CABLE

Make sure all fluid are removed and spark plug is disconnected.

Tools required:

- 10 mm wrench
- 13 mm wrench

To remove and replace your snowblower's self-drive cable, proceed as follows:

1. Carefully pivot the snowblower up and forward so that it rests on the auger housing. Place a piece of cardboard or moving blanket on the ground before tipping forward. Make sure all fluids are removed and spark plug is disconnected.
2. Remove the base frame cover (A) from the underside of the snowblower by removing the six M6 × 12 bolts. (Fig. 50)

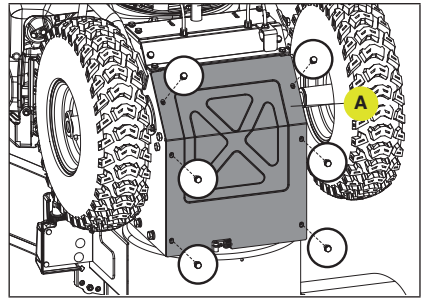

Figure 50

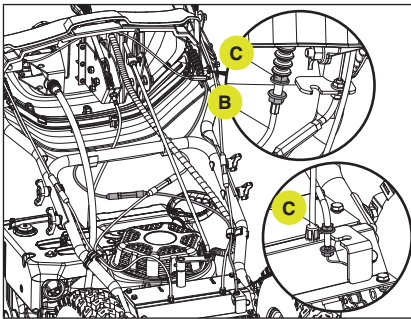

Figure 51

3. Locate the cable (B), slide back any rubber boot and loosen the top nuts (C) on each end of the cable as shown. (Fig. 51)

model no. 060-0609-0 | contact us: 1.866.523.5218

4. Unhook the connector (D) in the control handle. You may have to move the control handle to make this easier to remove. (Fig. 52)

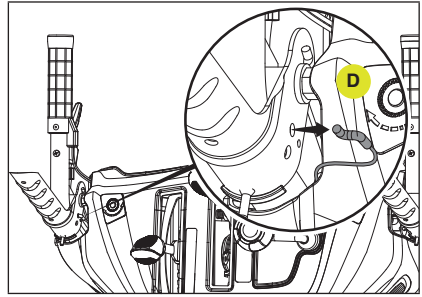

Figure 52

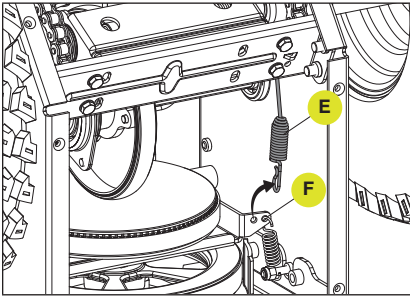

Figure 53

5. Unhook the spring (E) from the drive plate (F). (Fig. 53)
6. Perform the steps in reverse with the new cable.

## REPLACE AUGER CABLE

Make sure all fluids are removed and spark plug is disconnected.

Tools required:

- 10 mm wrench
- 13 mm wrench

To remove and replace your snowblower's auger cable, proceed as follows:

1. Remove the plastic belt cover on the front of the engine by removing two M6 × 12 bolts and flat washers. (Fig. 54)

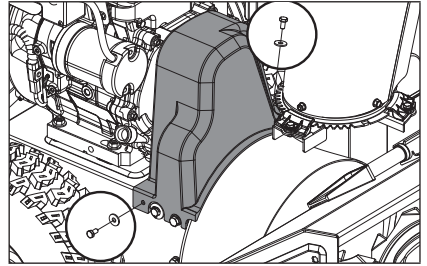

Figure 54

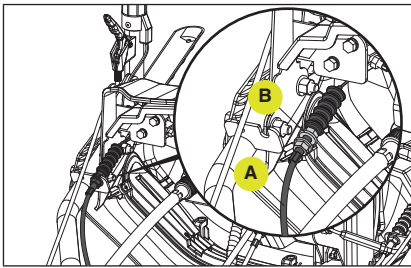

Figure 55

2. Locate the auger control cable (A), connected to the auger control lever on the left side (from behind the snowblower) under the control panel.
3. Slide back the rubber boot and loosen the tops nuts (B) on each end of the cable. (Fig. 55)

- Unhook the connector (C) in the control handle. You may have to move the control handle to make this easier to remove. (Fig. 56)

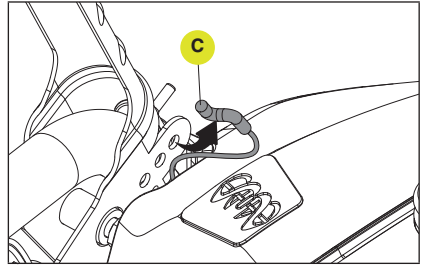

Figure 56

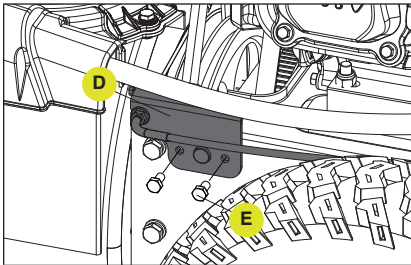

Figure 57

- Remove the auger plate (D) as shown on the front of the engine by removing two M6 x 12 bolts (E). (Fig. 57)

- Unhook the spring (F) from the auger plate (G). (Fig. 58)
- Perform the steps in reverse with the new cable.

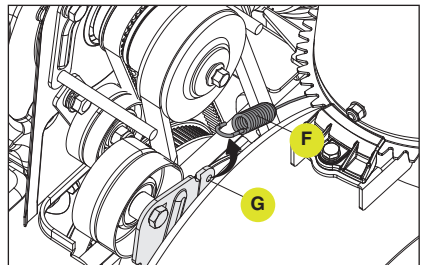

Figure 58

## REPLACE AUGER BELT

Make sure all fluids are removed and spark plug is disconnected.

Tools required:

- 10 mm wrench
- 13 mm wrench

To remove and replace your snowblower's auger belt, proceed as follows:

1. Remove the plastic belt cover on the front of the engine by removing two M6 x 12 bolts and flat washers. (Fig. 59)

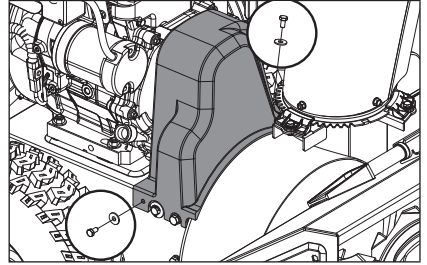

Figure 59

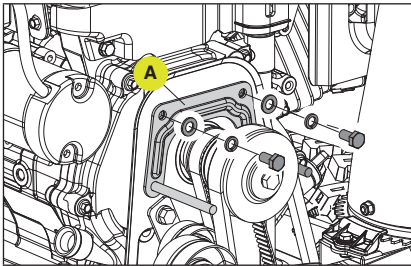

Figure 60

2. Remove belt guide (A) by removing two M8 x 20 bolts, flat and locking washers. (Fig. 60)



model no. 060-0609-0 | contact us: 1.866.523.5218

3. Unhook the spring (B) from the auger plate (C). (Fig. 61)

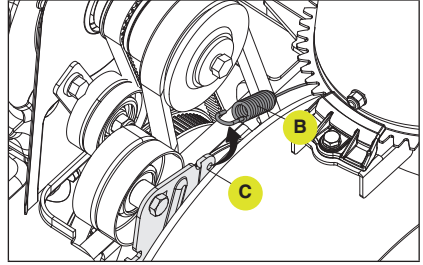

Figure 61

**MAINTENANCE**

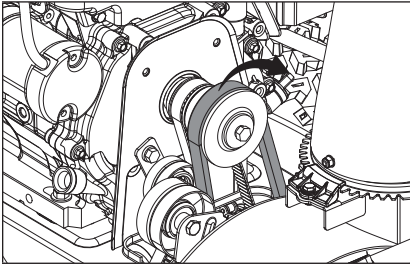

Figure 62

4. Slip the old auger drive belt off the engine pulley. (Fig. 62)

5. Remove auger housing from engine base by removing three M8 x 16 bolts, flat and locking washers on each side. (Fig. 63)

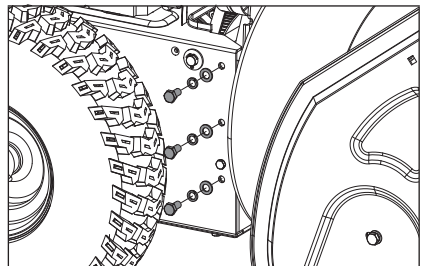

Figure 63

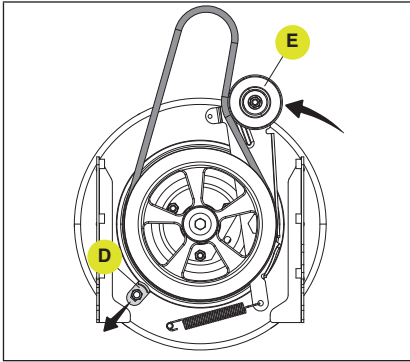

Figure 64

6. With the base and auger housing separated, use 13 mm wrench to loosen the M8 nut and slide lower belt guide (D) away from the auger pulley to give room to remove belt. Push the auger idler pulley (E) toward the large auger pulley to release the brake, and pull the belt off from the large pulley. (Fig. 64)
7. Perform the steps in reverse with the new belt.
8. Perform an auger test to confirm everything is in working order.

**⚠ WARNING:** If cutting the belt be careful of the idler pulley and arm as they are spring loaded and could cause injury when the belt is cut.

## REPAIR OR REPLACE FRICTION DISC

Make sure all fluids are removed and spark plug is disconnected.

Tools required:

- 13 mm wrench
- 22 mm wrench

To remove and replace your snowblower's friction disc, proceed as follows:

1. Carefully pivot the snowblower up and forward so that it rests on the auger housing. Place a piece of cardboard or moving blanket on the ground before tipping forward. Make sure all fluids are removed and spark plug is disconnected.
2. Remove the wheels by first removing the wheel clip and then sliding the wheels off the axles. (Fig. 65)

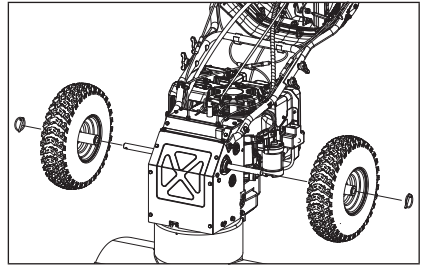

Figure 65

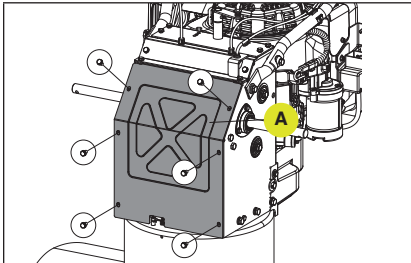

Figure 66

3. Remove the base frame cover (A) from the underside of the snowblower by removing the six M6 × 12 bolts. (Fig. 66)

4. Carefully remove the M8 hex bolt (B) on the left side which secures the hex shaft and chain gear shaft to the snowblower frame. Use a 22 mm or adjustable wrench (C) to hold the center of the hex shaft and use a 13 mm socket to remove the bolt on the left side. (Fig. 67)

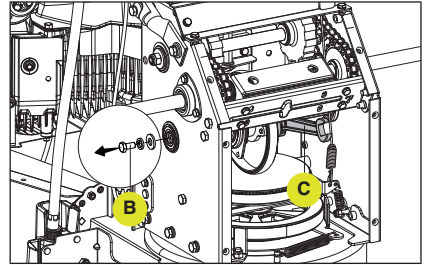

Figure 67

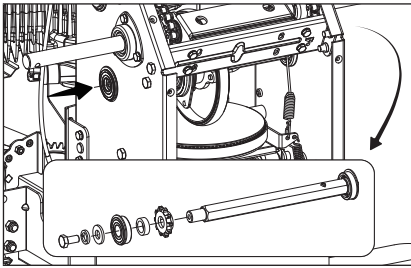

Figure 68

5. Slide out the hex shaft. Punch the shaft out from the left side. Make sure all pieces shown are accounted (only the shaft is removed, the chain sprocket wheel will remain on the chain). (Fig. 68)

6. Remove the friction disc. (Fig. 69)

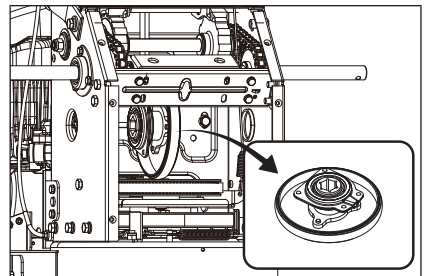

Figure 69

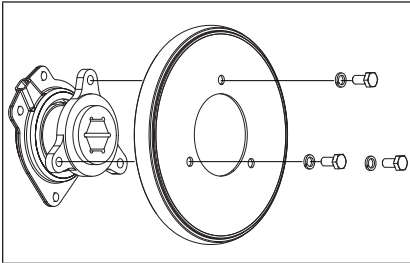

Figure 70

7. Unscrew the three M6 bolts along with 3 locking washers from the friction disc. Discard the worn friction disc and replace with a new one. Do not overtighten. (Fig. 70)

8. Clean the aluminum friction disc by wiping down with a clean cloth and follow the previous steps in reverse order to reassemble hexagon shaft parts. Make sure the parts are aligned as shown when finally assembled. (Fig. 71)
9. Perform the remaining steps in reverse to fully reassemble the snowblower.
10. Perform an drive test to confirm everything is in working order.

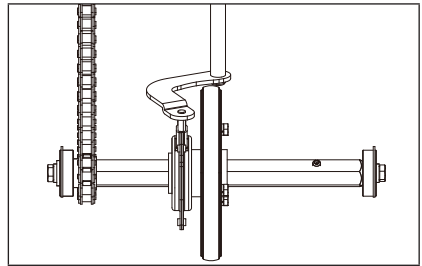

Figure 71

## REPLACE TRIGGER STEERING CABLE

Make sure all fluids are removed and spark plug is disconnected.

Tools required:

- Cross or Phillips-Head screwdriver
- 10 mm size wrench

To replace your snowblower's trigger steering system, proceed as follows:

1. Remove left, right or both right triggers (A) from their respective handles as shown. Shown is the left trigger. (Fig. 72)

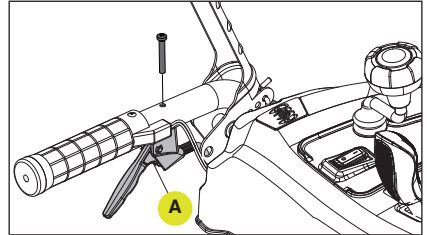

Figure 72

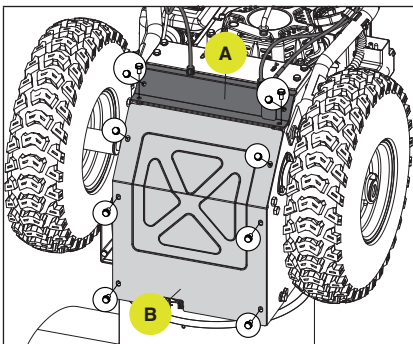

Figure 73

2. Carefully pivot the snowblower up and forward so that it rests on the auger housing. Place a piece of cardboard or moving blanket on the ground before tipping forward. Make sure all fluids are removed and spark plug is disconnected.
3. Remove the base frame covers (A and B) from the underside of the snowblower by removing the ten M6 × 12 bolts. (Fig. 73)

4. On the underside of the smaller cover, squeeze and remove the strain relief from the metal plate. This will dislodge the cable from the smaller base frame cover. (Fig. 74)

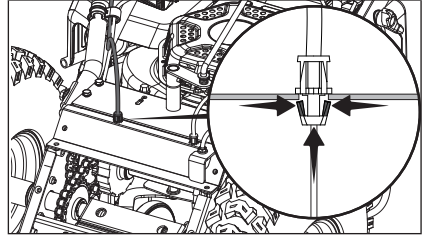

Figure 74

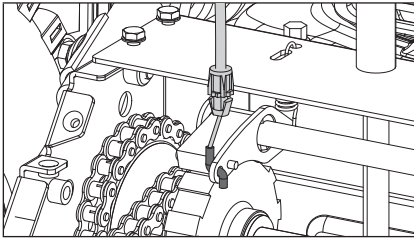

Figure 75

5. Unhook the connector. (Fig. 75)

6. On the trigger end, disconnect the connector. This will require some effort to disconnect. (Fig. 76)

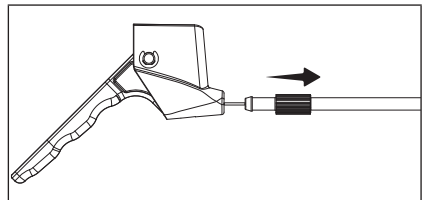

Figure 76

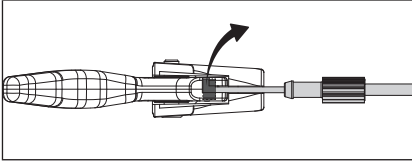

Figure 77

7. Unhook the connector. (Fig. 77)
8. Perform the steps in reverse to fully reassemble the snowblower.
9. Perform a drive test to confirm everything is in working order.

## REPLACE CHUTE DEFLECTOR CABLE

Make sure all fluids are removed and spark plug is disconnected.

Tools required:

- 13 mm wrench
- Needle nose pliers

To remove and replace your snowblower's chute deflector cable, proceed as follows:

1. Adjust deflector to fully upright, open position by moving the control all the way back. (Fig. 78)

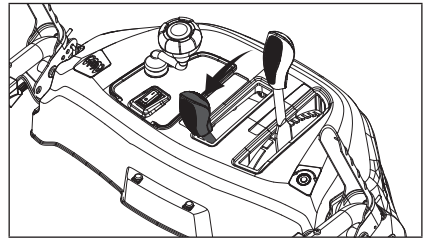

Figure 78

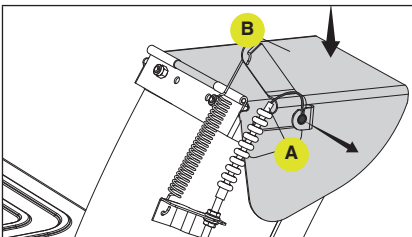

Figure 79

2. Locate the chute deflector cable (A), connected to the chute deflector (B), then push down on the chute deflector and remove the connector from the bracket. (Fig. 79)



model no. 060-0609-0 | contact us: 1.866.523.5218

- Slide back the rubber boot and completely loosen the top nut (C) on the end of the cable as shown so you can slide the cable out. (Fig. 80)

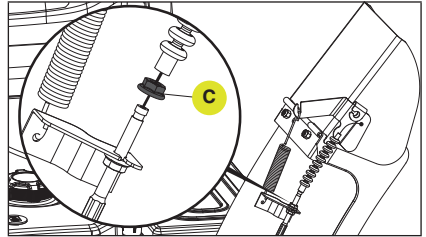

Figure 80

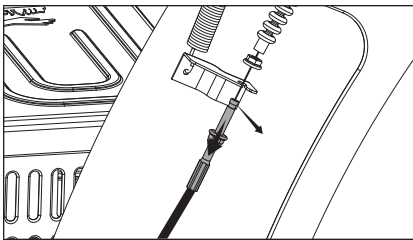

Figure 81

- Pull the cable downwards and remove the cable from the connector bracket on the chute. (Fig. 81)

- Move the control all the way forward. (Fig. 82)

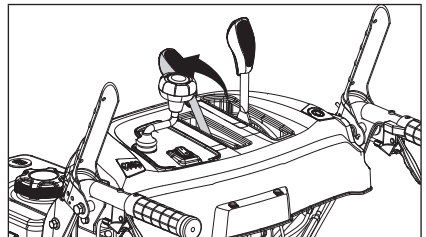

Figure 82

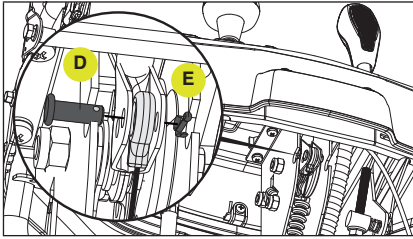

Figure 83

6. Under the control panel, location the chute deflector cable, remove both the pin (D) and cotter pin (E). (Fig. 83)

7. Completely loosen both nuts (F) on this cable. (Fig. 84)

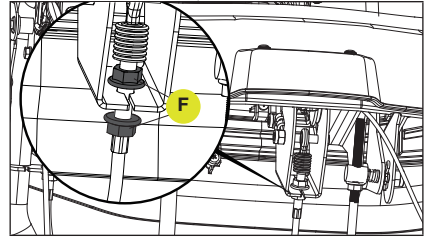

Figure 84

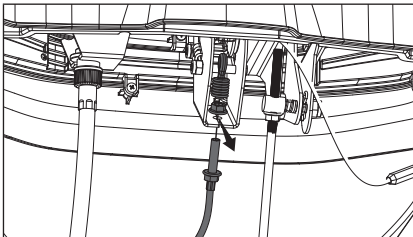

Figure 85

8. Remove the cable from the bracket. (Fig. 85)
9. Perform the steps in reverse with the new cable.

## REPLACE CLUTCH LOCK CABLE

Make sure all fluids are removed and spark plug is disconnected.

Tools required:

- 10 mm wrench

To replace your snowblower's clutch lock cable, proceed as follows:

1. On the underside of the control panel, loosen the top nut (A) from the clutch cable on the right. (Fig. 86)

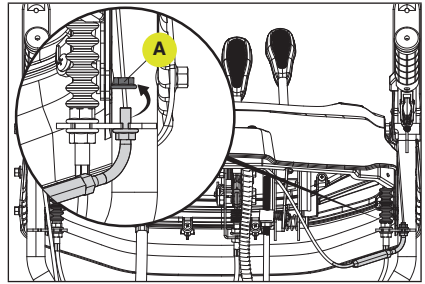

Figure 86

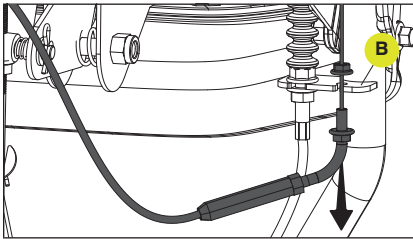

Figure 87

2. Pull down on the cable to remove it from the metal plate (B) holding it in place. (Fig. 87)

3. Remove the connector (C) from the self-drive control lever. (Fig. 88)

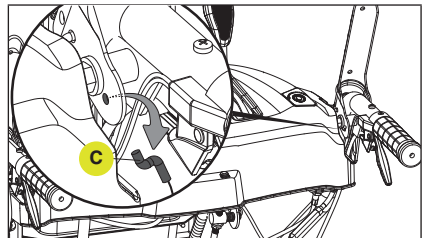

Figure 88

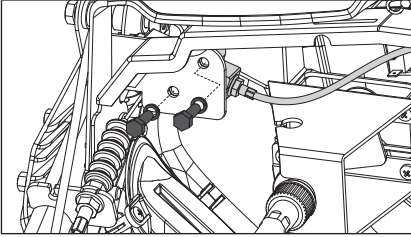

Figure 89

4. Remove the two M6 x 20 bolts and lock washers from the plate underneath the control panel near the auger control lever. (Fig. 89)

5. Loosen the nut from the compression spring barrel. (Fig. 90)

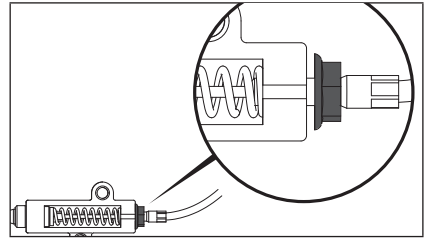

Figure 90

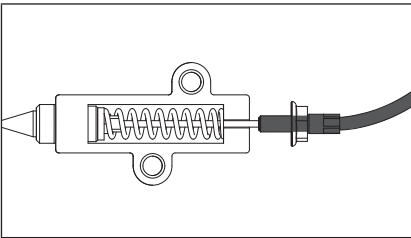

Figure 91

6. Loosen the cable from the spring barrel, by turning counterclockwise. (Fig. 91)

7. Remove spring assembly. (Fig. 92)

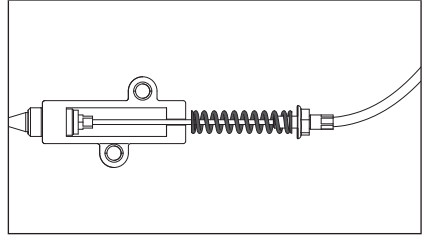

Figure 92

8. Remove the cable compression spring barrel. (Fig. 93)
9. Reassemble new clutch cable in reverse order.
10. Perform a drive test to confirm everything is in working order.

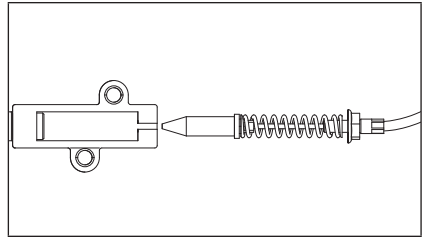

Figure 93

## GENERAL LUBRICATION

All bearings and bushings are permanently lubricated and require no maintenance. Lubricating these parts will only result in the grease getting on to the friction wheel and disc drive plate, which could damage the rubber clad friction wheel.

## GEAR BOX LUBRICATION

Add grease to auger gear box every 50 hours, or every 2 years.

Tools Required:

- Grease gun
  - #2 Phillips Screwdriver
1. Clean dirt off the zerk fitting (A) and the M5 x 10 cross recessed bolt (B). (Fig. 94)
  2. Use a Phillips screwdriver to remove the M5 x 10 cross recessed bolt (B). (Fig. 94)

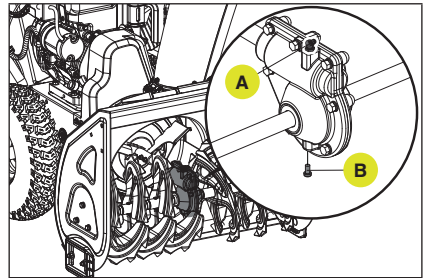

Figure 94

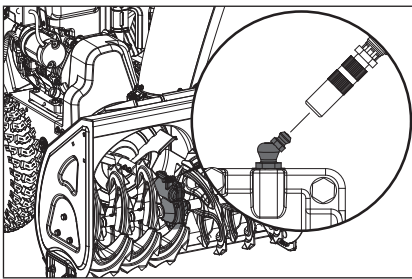

Figure 95

3. Use Low Temp NLGI #2 grease lithium base in a grease gun.
4. Attach grease gun to zerk fitting. (Fig. 95)
5. Add grease by 8 -10 pumps to push old dirty grease out the bottom drain hole.
6. Stop pumping when fresh grease comes out of the drain hole.
7. Reinstall the M5 x 10 cross recessed bolt. Tighten until snug.

## VALVE CLEARANCE

If set in summer: (if set at room temperature about 50°F – 86°F (10°C-30°C) intake clearance 0.10~0.15mm (.004”-.006”) exhaust clearance 0.15~0.20mm (.006”-.008”)

If set in winter: (if set in cold at < 32°F (0°C) then recommend setting a little tighter at: intake clearance 0.05~0.10mm (.002”-.004”) exhaust clearance 0.10~0.15mm (.004”-.006”)

## REGULAR SERVICE PERIODS

Perform at every indicated year or operating hour interval, whichever comes first.

Item	Service	Each Use	Every year or 20 hrs.	Every 2 years or 50 hrs.	Every 4 years or 100 hrs.	Every 6 years or 150 hrs.
Engine Oil	Check level	<input type="checkbox"/>				
	Change		<input type="checkbox"/>			
Spark Plug	Check/Clean				<input type="checkbox"/>	
	Replace					<input type="checkbox"/>
Spark Arrester (optional parts)	Clean				<input type="checkbox"/>	
Auger Gear Box	Grease			<input type="checkbox"/>		
Tire Pressure	Check-adjust		<input type="checkbox"/>			
Skid Shoe	Check-adjust height	<input type="checkbox"/>				
Idle Speed	Check-adjust					<input type="checkbox"/> (1)
Valve Clearance	Check-adjust					<input type="checkbox"/> (1)
Fuel Tank and Strainer	Clean					<input type="checkbox"/> (1)
Fuel Line	Check	Every 2 years (replace if necessary) (1)				

(1) These items should be serviced by your servicing dealer unless you have the proper tools and are mechanically proficient.

**⚠ NOTICE:** For Emission control devices and systems, read and understand your responsibilities for service as stated in the Emission Control Warranty Statement of this manual.

**LONG-TERM STORAGE**

Never store the machine with gasoline in the fuel tank in a confined area with bad ventilation. Gasoline fumes could reach open flames, sparks, cigarettes, etc.

To avoid the engine freezing and problems starting the engine, leave the engine running for 5-10 minutes after your work has been completed. This will ensure all moisture will disappear that would otherwise cause starting problems.

If the machine is to be stored for a longer period than 30 days, the following procedures are recommended.

1. Mix fuel stabilizer with gasoline according to fuel stabilizer manufacturer's directions.
2. Start the engine and let it run until it stops due to lack of fuel.
3. Change the engine oil if it has not been done for 3 months.
4. Remove the spark plug and empty a little engine oil (about 1 oz {30 mL}) in the hole. Crank the engine a couple of times. Replace the spark plug.
5. Clean the whole machine thoroughly.
6. Inspect the machine for damage, and repair if necessary.
7. Apply rust protection to the metal surfaces.
8. Store the machine indoors if possible.

**TRANSPORTING**

If the engine has been running, allow it to cool for at least 15 minutes before loading the machine on the transport vehicle. A hot engine and exhaust system can burn you and can ignite some materials.

Keep the engine level when transporting to reduce the possibility of fuel leakage. Move the fuel valve lever to the OFF position.

**⚠ WARNING: Never operate a damaged or defective snow blower.**

**⚠ WARNING: Improper maintenance will void your warranty.**



PROBLEM	POSSIBLE CAUSE	REMEDY
Engine fails to start.	Engine flooded.	Repeat start attempts with choke OFF.
	Water in fuel.	Drain tank and refill with fresh fuel.
	Other.	Check carefully the start procedure according to this manual.
	Red ignition key pulled out or missing.	Push in red key. If key is lost, you may use a wood Popsicle stick as a temporary key until Red key is found or replaced.
Engine starts hard or runs poorly.	Spark plug issues.	Replace the spark plug.
	Fuel cap ventilation is blocked.	Clear the ventilation or replace cap.
Auger does not rotate.	Foreign material caught in system.	Clean.
	Auger drive belt slipping.	Adjust the belt cable to increase tension.
	Auger drive belt broken.	Replace the belt.
	Shear pin broken.	Replace the shear pin.
Auger does not stop when the lever is released.	Auger drive belt is out of adjustment.	Adjust the belt cable to decrease tension.
	Auger drive guide is out of adjustment.	Adjust the guide.
Snowblower veers to one side.	Wheel spring lock pin is inserted on one side.	Check the wheel locks.
	Shoes are mounted unevenly.	Adjust shoes.
	Scraper blade uneven.	Adjust scraper blade and shoes.
Snowblower does not drive.	Drive belt worn/broken.	Replace traction drive belt.
	Friction disc worn out.	Repair or replace friction disc.
	Drive belt slipping.	Adjust the belt cable to increase tension.
	Oil or grease contamination on aluminum drive disc.	Clean off aluminum drive disk with solvent, such as, brake cleaner.
	Water drip onto aluminum drive disk.	Sometimes wet snow near 0°C (32°F) may melt and drip onto aluminum drive disc. Wait 2-4 minutes for the water to evaporate and then try wheel drive.

#### 4-YEAR LIMITED WARRANTY

For Four YEARS from the date of purchase within Canada, YARDWORKS CANADA will, at its option, repair or replace for the original purchaser, free of charge, any part or parts found to be defective in material or workmanship.

#### THIS WARRANTY DOES NOT COVER:

1. Any part that has become inoperative due to misuse, commercial use, abuse, neglect, accident, improper maintenance, or alteration;
2. The unit, if it has not been operated and/or maintained in accordance with the owner's manual;
3. Normal wear parts like belts, skid shoes and shave plates except as noted below;
4. Routine maintenance items such as oil, spark plug, fuel line; or
5. Normal deterioration of the exterior finish due to use or exposure.

#### FULL 270-DAY WARRANTY ON NORMAL WEAR PARTS:

Normal wear parts are defined as wheels, tires, belts, drive disc, skid shoes and shave plate. These parts are warranted to the original purchaser to be free from defects in material and workmanship for a period of two hundred seventy (270) days from the date of retail purchase.

#### HOW TO OBTAIN SERVICE:

Warranty service is available by calling the toll-free helpline at 1.866.523.5218.

The factory will not accept the return of a complete unit unless prior written permission has been extended by YARDWORKS CANADA.

#### TRANSPORTATION CHARGES:

Transportation charges for the movement of the snowblower or accessories are the responsibility of the purchaser. The purchaser must pay transportation charges for any part submitted for replacement under this warranty unless such return is requested in writing by YARDWORKS CANADA.

#### OTHER WARRANTIES:

All other warranties, express or implied, including any implied warranty of merchantability is limited in its duration to that set forth in this express limited warranty. The provisions as set forth in this warranty provide the sole and exclusive remedy of YARDWORKS CANADA obligations arising from the sale of its products.



model no. 060-0609-0 | contact us: 1.866.523.5218

### **ADDITIONAL LIMITATIONS**

This warranty applies only to the original purchaser and may not be transferred. Neither the retailer nor the manufacturer shall be liable for any other expense, loss or damage, including, without limitation, any indirect, incidental, consequential or exemplary damages arising in connection with the sale, use or inability to use this product.

### **NOTICE TO CONSUMER**

This warranty gives you specific legal rights, and you may have other rights, which may vary from province to province. The provisions contained in this warranty are not intended to limit, modify, take away from, disclaim or exclude any statutory warranties set forth in any applicable provincial or federal legislation.

Made in China

Imported by  
Trileaf Distribution Toronto, Canada M4S 2B8

**WARRANTY**

**YARDWORKS CANADA will not be liable for incidental or consequential loss or damage.**

**CHAMPION POWER EQUIPMENT, INC. (CPE)  
AND UNITED STATES ENVIRONMENT PROTECTION AGENCY (U.S. EPA)  
EMISSION CONTROL SYSTEM WARRANTY**

**Your Champion Power Equipment (CPE) engine complies with U.S. EPA emissions regulations.**

**YOUR WARRANTY RIGHTS AND OBLIGATIONS:**

The US EPA and CPE are pleased to explain the Federal Emission Control Systems Warranty on your 2023 small off-road engine (SORE) and engine powered equipment. New engines and equipment must be designed, built and equipped, at the time of sale, to meet U.S. EPA regulations for small off-road engines (SORE). CPE warrants the emission control system on your small off-road engine (SORE) and equipment for the period of time listed below, provided there has been no abuse, neglect, unapproved modification, or improper maintenance of your equipment.

Your emission control system may include parts such as the carburetor, fuel-injection system, the ignition system, catalytic converter and fuel lines. Also included may be hoses, belts, connectors and other emission related assemblies. Where a warrantable condition exists, CPE will repair your small off-road engine (SORE) at no cost to you including diagnosis, parts and labor.

**MANUFACTURER'S EMISSION CONTROL SYSTEM WARRANTY COVERAGE:**

This emission control system is warranted for two years, subject to provisions set forth below. If, during the warranty period, an emission related part on your engine is defective in materials or workmanship, the part will be repaired or replaced by CPE.

**OWNER WARRANTY RESPONSIBILITIES:**

As the small off-road engine (SORE) owner, you are responsible for the performance of the required maintenance listed in your Owner's Manual. CPE recommends that you retain all your receipts covering maintenance on your small off-road engine, but CPE cannot deny warranty solely for the lack of receipts or for your failure to ensure the performance of all scheduled maintenance.

As the small off-road engine (SORE) owner, you should however be aware that CPE may deny you warranty coverage if your small, off-road engine (SORE) or a part has failed due to abuse, neglect, improper maintenance or unapproved modifications.

You are responsible for presenting your small off-road engine (SORE) to an Authorized CPE service outlet or alternate service outlet as described in (3)(f.) below, CPE dealer or CPE, Santa Fe Springs, Ca. as soon as a problem exists. The warranty repairs should be completed in a reasonable amount of time, not to exceed 30 days.

If you have any questions regarding your warranty rights and responsibilities, you should contact:

Champion Power Equipment, Inc.  
Customer Service  
12039 Smith Ave.  
Santa Fe Springs, CA 90670  
1-877-338-0999  
tech@championpowerequipment.com

## **EMISSION CONTROL SYSTEM WARRANTY**

**The following are specific provisions relative to your Emission Control System (ECS) Warranty Coverage.**

- 1. APPLICABILITY:** This warranty shall apply to 1997 and later model year small off-road engines (SORE). The ECS Warranty Period shall begin on the date the new engine or equipment is delivered to its original, end-use purchaser, and shall continue for 24 consecutive months thereafter.
- 2. GENERAL EMISSIONS WARRANTY COVERAGE**

CPE warrants to the original, end-use purchaser of the new engine or equipment and to each subsequent purchaser that each of its small off-road engines (SORE) is:

  - 2a. Designed, built and equipped so as to conform to U.S. EPA emissions standards for spark-ignited engines at or below 19 kilowatts.
  - 2b. Free from defects in materials and workmanship that cause the failure of a warranted part to be identical in all material respects to the part as described in the engine manufacturer's application for certification for a period of two years.
- 3. THE WARRANTY ON EMISSION-RELATED PARTS WILL BE INTERPRETED AS FOLLOWS:**
  - 3a. Any warranted part that is not scheduled for replacement as required maintenance in the Owners Manual shall be warranted for the ECS Warranty Period. If any such part fails during the ECS Warranty Period, it shall be repaired or replaced by CPE according to Subsection "d" below. Any such part repaired or replaced under the ECS Warranty shall be warranted for any remainder of the ECS Warranty Period.
  - 3b. Any warranted, emissions-related part which is scheduled only for regular inspection as specified in the Owners Manual shall be warranted for the ECS Warranty Period. A statement in such written instructions to the effect of "repair or replace as necessary", shall not reduce the ECS Warranty Period. Any such part repaired or replaced under the ECS Warranty shall be warranted for the remainder of the ECS Warranty Period.
  - 3c. Any warranted, emissions-related part which is scheduled for replacement as required maintenance in the Owner's Manual shall be warranted for the period of time prior to the first scheduled replacement point for that part. If the part fails prior to the first scheduled replacement, the part shall be repaired or replaced by CPE according to Subsection "d" below. Any such emissions-related part repaired or replaced under the ECS Warranty, shall be warranted for the remainder of the ECS Warranty Period prior to the first scheduled replacement point for such emissions-related part.
  - 3d. Repair or replacement of any warranted, emissions-related part under this ECS Warranty shall be performed at no charge to the owner at a CPE Authorized Service Outlet.
  - 3e. The owner shall not be charged for diagnostic labor which leads to the determination that a part covered by the ECS Warranty is in fact defective, provided that such diagnostic work is performed at a CPE Authorized Service Outlet.
  - 3f. CPE shall pay for covered emissions warranty repairs at non-authorized service outlets under the following circumstances:
    - i. The service is required in a population center with a population over 100,000 according to U.S. Census 2000 without a CPE Authorized Service Outlet AND
    - ii. The service is required more than 100 miles from a CPE Authorized Service Outlet. The 100 mile limitation does not apply in the following states: Alaska, Arizona, Colorado, Hawaii, Idaho, Montana, Nebraska, Nevada, New Mexico, Oregon, Texas, Utah and Wyoming.
  - 3g. CPE shall be liable for damages to other original engine components or approved modifications proximately caused by a failure under warranty of an emission-related part covered by the ECS Warranty.
  - 3h. Throughout the ECS Warranty Period, CPE shall maintain a supply of warranted emission-related parts sufficient to meet the expected demand for such emission-related parts.

- 3i. Any CPE Authorized and approved emission-related replacement part may be used in the performance of any ECS Warranty maintenance or repair and will be provided without charge to the owner. Such use shall not reduce CPE's warranty obligation.
- 3j. Unapproved add-on or modified parts may not be used to modify or repair a CPE engine. Such use voids this ECS Warranty and shall be sufficient grounds for disallowing an ECS Warranty claim. CPE shall not be liable hereunder for failures of any warranted parts of a CPE engine caused by the use of such an unapproved add-on or modified part.

**EMISSION-RELATED PARTS INCLUDE THE FOLLOWING:  
(using those portions of the list applicable to the engine)**

Systems covered by this warranty	Parts Description
Fuel Metering System	Fuel regulator, Carburetor and internal parts
Air Induction System	Air cleaner, Intake manifold
Ignition System	Spark plug and parts, Magneto ignition system
Exhaust System	Exhaust manifold, catalytic converter
Miscellaneous Parts	Tubing, Fittings, Seals, Gaskets, and Clamps associated with these listed systems.
Evaporative Emissions	Fuel Tank, Fuel Cap, Fuel Lines (for liquid fuel and fuel vapors), Fuel Line Fittings, Clamps, Pressure Relief Valves, Control Valves, Control Solenoids, Electronic Controls, Vacuum Control Diaphragms, Control Cables, Control Linkages, Purge Valves, Gaskets, Liquid/Vapor Separator, Carbon Canister, Canister Mounting Brackets, Carburetor Purge Port Connector

**TO OBTAIN WARRANTY SERVICE:**

You must take your CPE engine or the product on which it is installed, along with your warranty registration card or other proof of original purchase date, at your expense, to any Champion Power Equipment dealer who is authorized by Champion Power Equipment, Inc. to sell and service that CPE product during his normal business hours. Alternate service locations defined in Section (3)(f.) above must be approved by CPE prior to service. Claims for repair or adjustment found to be caused solely by defects in material or workmanship will not be denied because the engine was not properly maintained and used.

**If you have any questions regarding your warranty rights and responsibilities, or to obtain warranty service, please write or call Customer Service at Champion Power Equipment, Inc.**

**Champion Power Equipment, Inc.**  
 12039 Smith Ave.  
 Santa Fe Springs, CA 90670  
 1-877-338-0999  
 Attn.: Customer Service  
[tech@championpowerequipment.com](mailto:tech@championpowerequipment.com)