

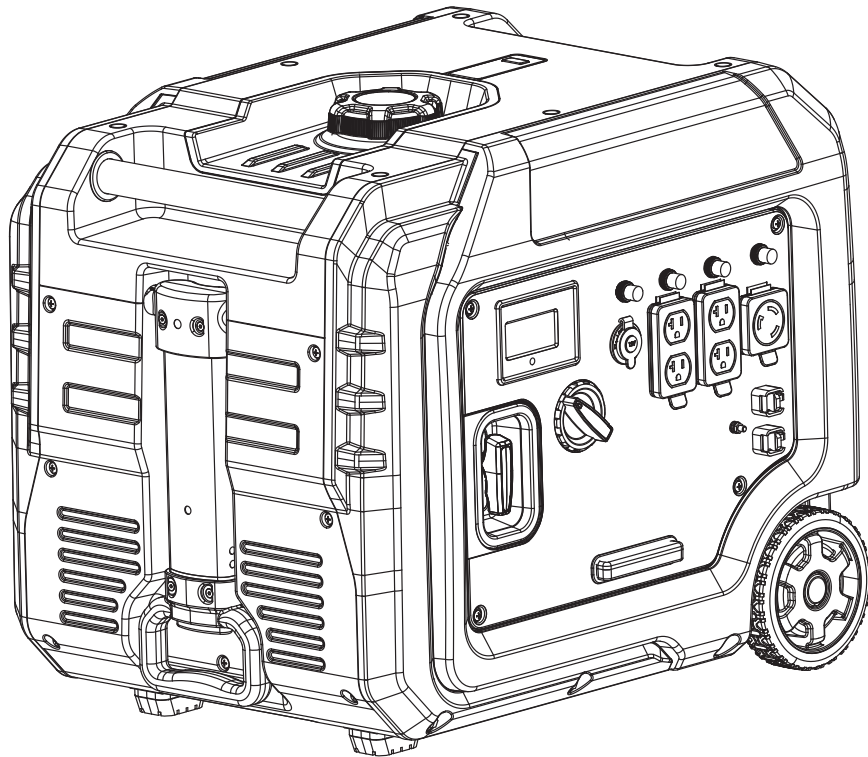

Champion Power Equipment, Inc., Santa Fe Springs, CA USA

MODEL #201242



PARTS INFORMATION

5500W PORTABLE INVERTER GENERATOR

SERIAL NUMBER RANGE: ALL



To order replacement parts please visit:
shop.championpowerequipment.com
or call **1-877-338-0999**.

TABLE OF CONTENTS

Inverter Generator Parts Diagram	3
Inverter Generator Parts List	4
Engine Parts Diagram	6
Engine Parts List	7
Cylinder Head Parts Diagram	9
Cylinder Head Parts List	10
Carburetor Parts Diagram	11
Carburetor Parts List	12
Fuel Tank Parts Diagram	13
Fuel Tank Parts List	14
Control Panel Parts Diagram	15
Control Panel Parts List	16
Frame Assembly Parts Diagram	17
Frame Assembly Parts List	18
Wiring Diagram	19

INVERTER GENERATOR PARTS DIAGRAM

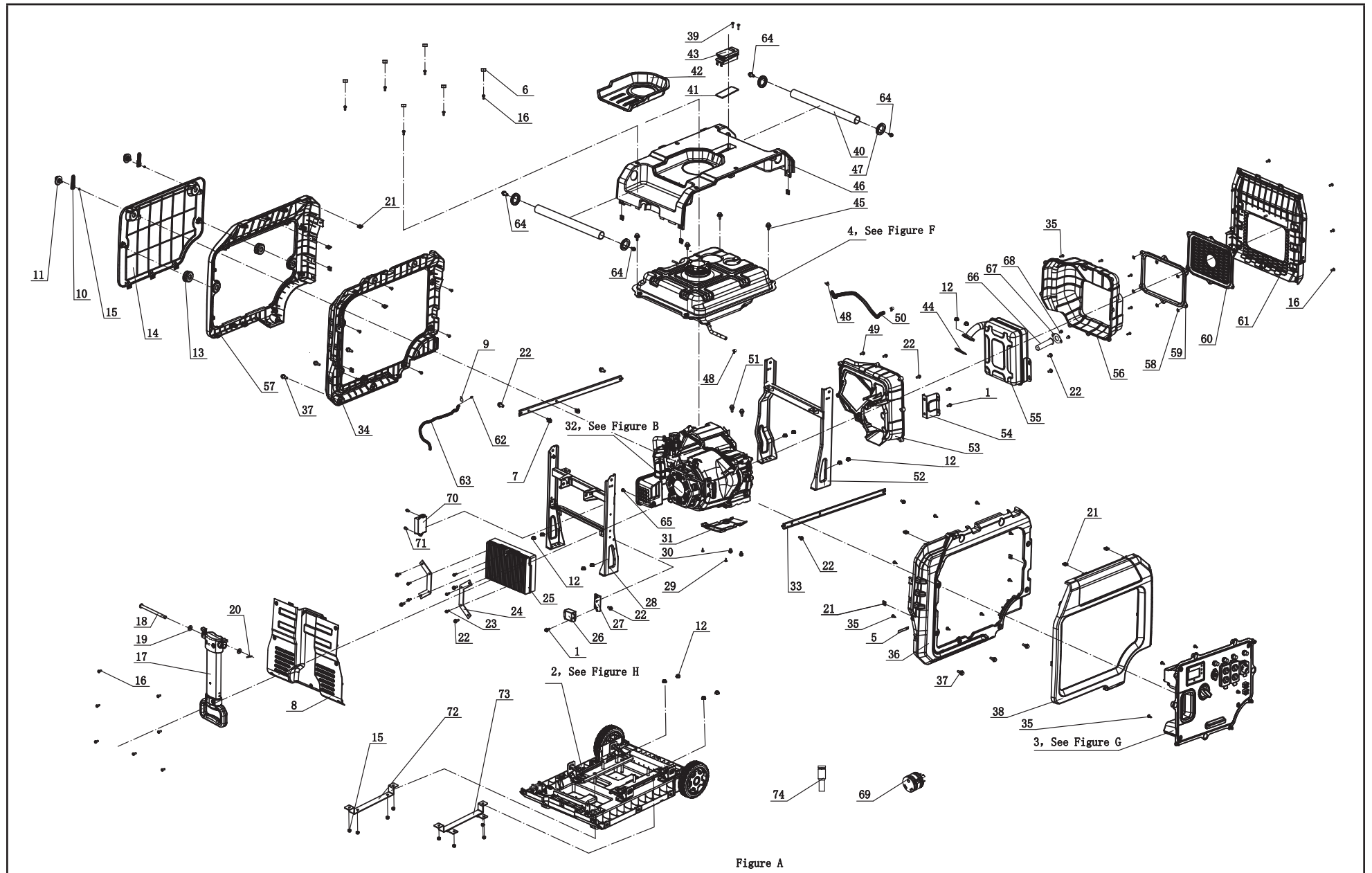

Figure A

INVERTER GENERATOR PARTS LIST

#	Part Number	Description	Qty.
1	1.5789.0615	Flange Bolt M6 x 15	3
2	63.200600.01	Base Setting Component Assembly, See Figure H	1
3	63.210000.07	Control Panel Assembly, See Figure G	1
4	63.070000.01	Fuel Tank Assembly, See Figure F	1
5	2.05.050	Clamp, Wire, 100	3
6	63.200503.00	Cover, Connect Port	6
7	2.05.001	Clamp, Ø8 x 6.5	2
8	63.200200.01	Cover, Left, CSA	1
9	2.06.006	Clamp, Ø7 x Ø1	1
10	63.200410.01	Cover, Rotary Knob	2
11	63.200410.00	Rotary Knob, Protector, Rear Cover	2
12	1.6177.1.08	Lock Nut M8, Flange	14
13	63.200103.00	Rubber Sleeve	2
14	63.200402.02	Protector, Rear Cover, CSA	1
15	1.6177.1.06	Lock Nut M6, Flange	10
16	1.818.0514.1	Screw M5×14	22
17	63.200700.00	Handle Assembly	1
18	63.200509.00	Handle, Pin	1
19	2.03.073	Bushing	2
20	2.16.006	Cotter Pin, (Ø2×20)	1
21	2.02.010	Cage Nut M5	20
22	1.5789.0612	Flange Bolt M6 x 12	13
23	1.5789.0512	Flange Bolt M5 x 12	5
24	63.220004.00	Holder, Control Unit	2
25	63.221000.02	Control Unit, 4.0KW, 120V/60Hz, Wireless Parallel	1
26	5.1800.011	Rectifier	1
27	63.200018.01	Support Arm	1
28	63.201100.03	Supporter, Left	1

#	Part Number	Description	Qty.
29	1.845.3595	Screw, ST3.5 x 9.5	2
30	1.5789.0610	Flange Bolt M6 x 10	2
31	63.080600.00	Protector Assembly, Lower	1
32	63.402	Engine, 224 cc, See Figure B	1
33	63.201600.03	Supporter, Fuel Tank	2
34	63.200401.03	Supporter, Rear Cover, CSA, Black	1
35	1.845.4216	Screw, ST4.2 x 16	29
36	63.200101.03	Supporter, Front Cover, t, CSA, Black	1
37	2.08.075.1	Bolt M6 x 20	6
38	63.200101.02	Front Covert, CSA	1
39	1.823.0325	Screw M3×25	2
40	63.200700.01	Handle	2
41	63.213004.02	Rubber Pad	1
42	63.200502.00	Spillway, Fuel Tank	1
43	63.214000.00	Indicator Light Assembly, Fuel Tank	1
44	26.100001.00	Gasket, Exhaust	1
45	2.08.179.1	Flange Bolt M6 x 25	4
46	63.200500.01	Cover, Top, CSA, Black	1
47	63.200102.00	Rubber Sleeve	4
48	2.06.018	Clamp, Ø10.5 x b8	3
49	2.08.102	Screw M6×13	1
50	63.070011.01	Fuel Pipe, Fuel Valve To Carburetor	1
51	2.08.168	Bolt	2
52	63.201100.02	Supporter, Right	1
53	63.081100.00	Muffler Protector Assembly, Front	1
54	63.101005.00	Supporter, Muffler Assembly	1
55	63.101000.00.2	Muffler Assembly	1
56	63.081200.00	Muffler Protector Assembly, Rear	1
57	63.200401.02	Supporter, Rear Cover, CSA, Black	1
58	2.03.069	Retaining Ring, M5	6

#	Part Number	Description	Qty.
59	63.200304.00	Rubber Seal, Muffler Cover	1
60	63.200303.01	Muffler Cover, CSA	1
61	63.200302.01	Cover, Right Side, CSA, Black	1
62	24.070030.00	Hole, Breather Tube	1
63	63.070014.01	Pipe, Fuel Tank To Canister	1
64	1.16674.0812	Flange Bolt M8 x 12	4
65	1.818.0514.1	Screw M5x20	2
66	46.101300.08	Spark Arrester Assembly	1
67	46.101503.08	Plate, Spark Arrester	1
68	1.9074.13.0514	Screw/Washer Assembly M5 x 10	2
69	9.3000.016	Rv Adaptor Plug	1
70	5.1830.022	Module, CO Shutdown	1
71	1.16674.0516	Bolt M5 x 16	2
72	63.202400.01	Transportation Support 2	1
73	63.202400.00	Transportation Support 1	1
74	9.1130.000.1	Wrench, 10, Black	1

ENGINE PARTS DIAGRAM

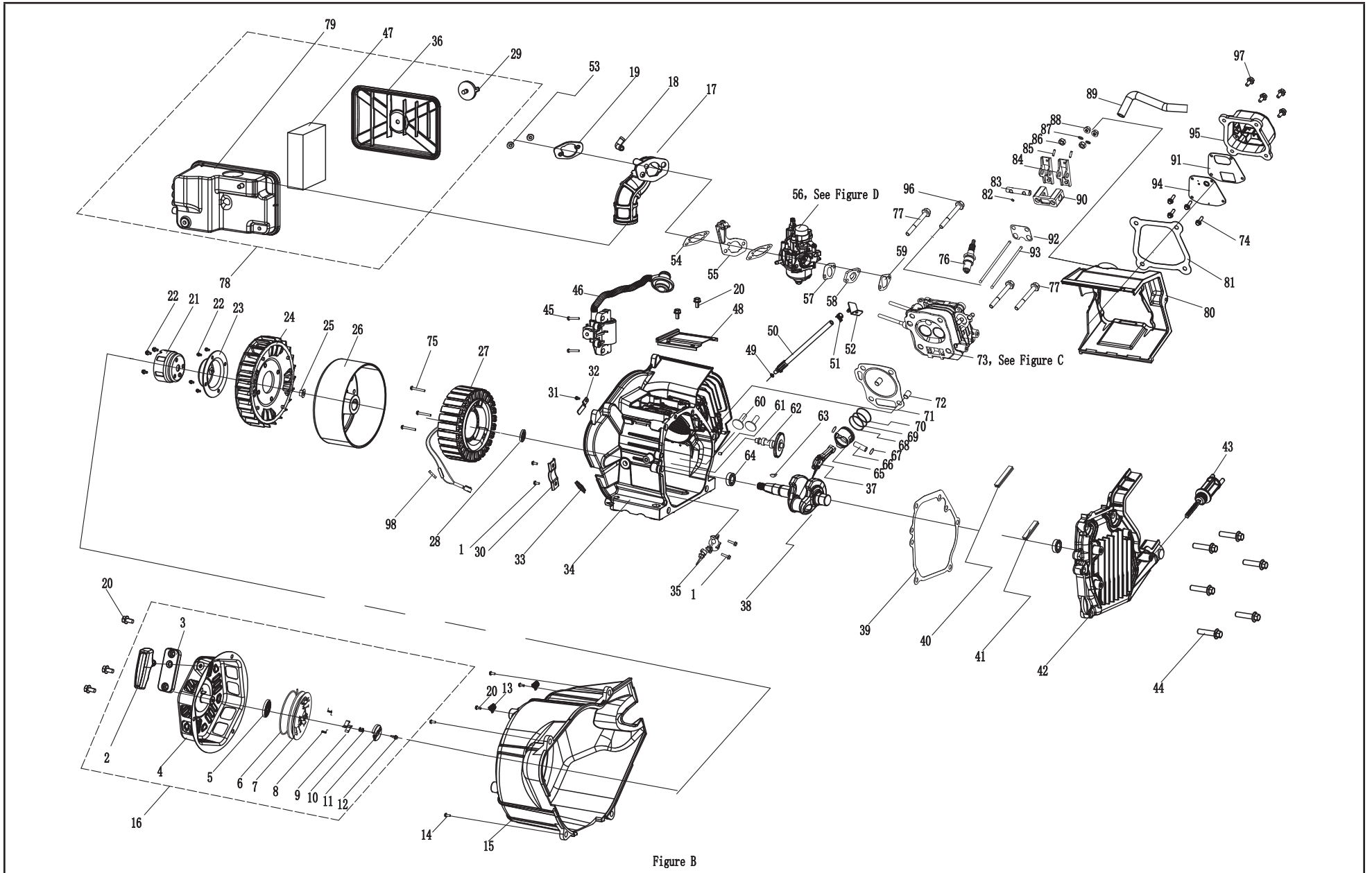

Figure B

ENGINE PARTS LIST

#	Part Number	Description	Qty.
1	1.5789.0612	Flange Bolt M6 x 12	4
2	62.061300.00	Handle, Recoil, Soft	1
3	63.061200.00	Handle Guide Plate	1
4	83.061100.01.1	Cover, Recoil Starter, Black	1
5	21.061005.00	Spring, Recoil Starter	1
6	2.10.001.1	Rope Ø4x1570, Black	1
7	21.061001.01	Reel, Recoil Starter	1
8	45.060003.00	Spring, Ratchet	2
9	45.060002.00	Starter Ratchet, Steel	2
10	45.060009.00	Spring Guide, Ratchet	1
11	45.060007.00	Ratchet Guide	1
12	45.060008.00	Screw, Ratchet Guide	1
13	2.05.050	Clamp, Wire, 100	2
14	1.5789.0620	Flange Bolt M6 x 20	4
15	63.080100.00	Fan Cover	1
16	63.061000.00	Recoil Assembly	1
17	63.090004.02	Air Cleaner Tube	1
18	63.090003.00	Joint, Breather Pipe	1
19	63.090005.00	Pinch, Air Cleaner Tube	1
20	1.5789.0610	Flange Bolt M6 x 10	7
21	63.060001.00	Pulley, Starter	1
22	1.16674.0616	Flange Bolt M6 x 10	7
23	182.060002.00	Connecting Base	1
24	63.080001.00	Cooling Fan	1
25	2.02.006	Nut M14 x 1.5	1
26	63.191100.01	Rotor	1
27	63.191200.05	Stator Component	1
28	2.11.001	Oil Seal Ø25 x Ø41.3 x 6	1
29	62.200410.00	Rotary Knob, Protector, Rear Cover	1
30	182.030006.00	Pinch	1

#	Part Number	Description	Qty.
31	1.5789.0608	Flange Bolt M6 x 8	1
32	63.030006.01	Pinch	1
33	63.030032.00	Sheath, Wire	1
34	63.030100.00.1	Crankcase	1
35	21.127000.02	Oil Level Sensor	1
36	63.091200.00	Cover, Air Cleaner	1
37	27.050200.00	Connecting Rod	1
38	27.050100.04	Crankshaft	1
39	24.030008.00	Gasket, Crankcase Cover	1
40	27.030013.00	Seal Strip, Crankcase Cover, Long	1
41	27.030013.01	Seal Strip, Crankcase Cover, Short	1
42	63.030007.00	Cover, Crankcase	1
43	63.031000.00.2	Oil Dipstick Assembly	1
44	1.5789.0832	Flange Bolt M8 x 32	6
45	2.08.182	Flange Bolt M6 x 20	2
46	63.123000.01	Ignition Coil, Silicon Rubber	1
47	63.091003.00	Element, Air Cleaner	1
48	63.080300.00	Air Guide	1
49	2.03.016	Washer Ø10 x Ø16 x 1.5, Drain Bolt	1
50	83.032000.00	Hose, Oil Drain	1
51	2.06.013	Clamp	1
52	45.030200.00	Support	1
53	1.6177.06	Flange Nut M6	2
54	24.130004.20	Gasket, Air Cleaner	2
55	63.130200.01	Support, Choker Rod	1
56	63.130000.03	Carburetor Assembly, See Figure D	1
57	22.130003.00	Gasket, Carburetor	1
58	63.130001.00	Insulator, Carburetor	1
59	24.130002.00	Gasket, Insulator	1
60	25.040013.00	Lifter, Valve	2

#	Part Number	Description	Qty.
61	2.04.001	Dowel Pin Ø9 x 14	2
62	27.041000.00	Camshaft	1
63	2.14.012	Woodruff Key 4 x 7.5 x 19	1
64	1.276.6205.9	Bearing 6205	2
65	27.050005.00	Piston	1
66	23.050003.00	Pin, Piston	1
67	2.09.001	Circlip Ø18 x Ø1	2
68	27.050303.00	Ring, Oil	1
69	27.050302.00	Ring, Second Piston	1
70	27.050301.00	Ring, First Piston	1
71	27.030009.01	Gasket, Cylinder Head	1
72	2.04.003	Dowel Pin Ø10 x 14	2
73	63.010000.00	Cylinder Head Assembly, See Figure C	1
74	1.16674.0512.2	Flange Bolt M5 x 12	4
75	1.5789.0655	Flange Bolt M6 x 55	3
76	2.15.002(F6RTC)	Spark Plug F6RTC	1
77	1.5789.0865	Flange Bolt M8 x 65	3
78	63.091000.00	Air Cleaner Assembly	1
79	63.091100.00	Base, Air Cleaner	1
80	63.080200.00	Air Shroud, Cylinder	1
81	85.020002.00	Gasket, Cylinder Head Cover	1
82	21.040008.00	Rotator, Exhaust Valve	1
83	24.040202.00	Shaft, Rocker Arm	1
84	22.040009.00	Rocker Arm	2
85	22.040012.00	Screw, Valve Adjustment	2
86	21.040021.00	Nut M6 x 0.5, Lock	2
87	1.97.1.06	Washer Ø6	2
88	1.6177.1.06	Lock Nut M6, Flange	2
89	23.020001.03	Breather Tube	1
90	24.040201.00	Retainer, Rocker Arm	1
91	85.030022.00	Gasket, Ventilation Chamber Cover	1
92	24.040004.00	Guide Plate, Push Rod	1

#	Part Number	Description	Qty.
93	27.040005.00	Push Rod	2
94	85.030300.00	Ventilation Chamber Cover Assembly	1
95	85.021101.00	Cover, Cylinder Head	1
96	2.08.121	Flange Bolt M10 x 65	1
97	1.5789.0615	Flange Bolt M6 x 15	4
98	5.1280.011	Fuse, 15A	1

CYLINDER HEAD PARTS DIAGRAM

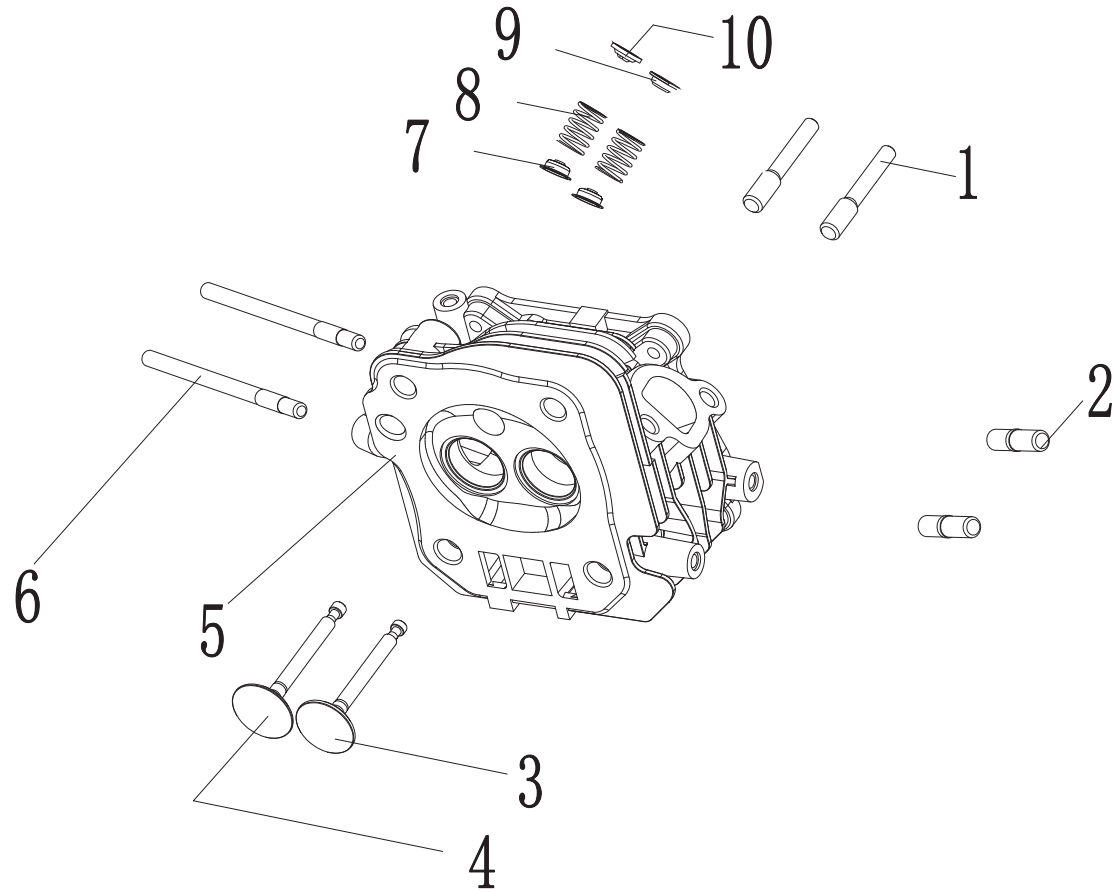

Figure C

CYLINDER HEAD PARTS LIST

#	Part Number	Description	Qty.
1	23.040010.00	Bolt, Rocker Arm	2
2	2.01.010	Stud Bolt M8 x 35	2
3	23.040006.02	Valve, Exhaust	1
4	23.040002.02	Valve, Intake	1
5	26.010100.01	Cylinder Head, 224cc	1
6	2.01.049	Stud Bolt M6 x 99	2
7	23.040017.00	Oil Seal, Valve, Steel	2
8	21.040003.00	Spring, Valve	2
9	21.040007.00	Retainer, Exhaust Valve Spring	1
10	21.040001.00	Retainer, Intake Valve Spring	1

CARBURETOR PARTS DIAGRAM

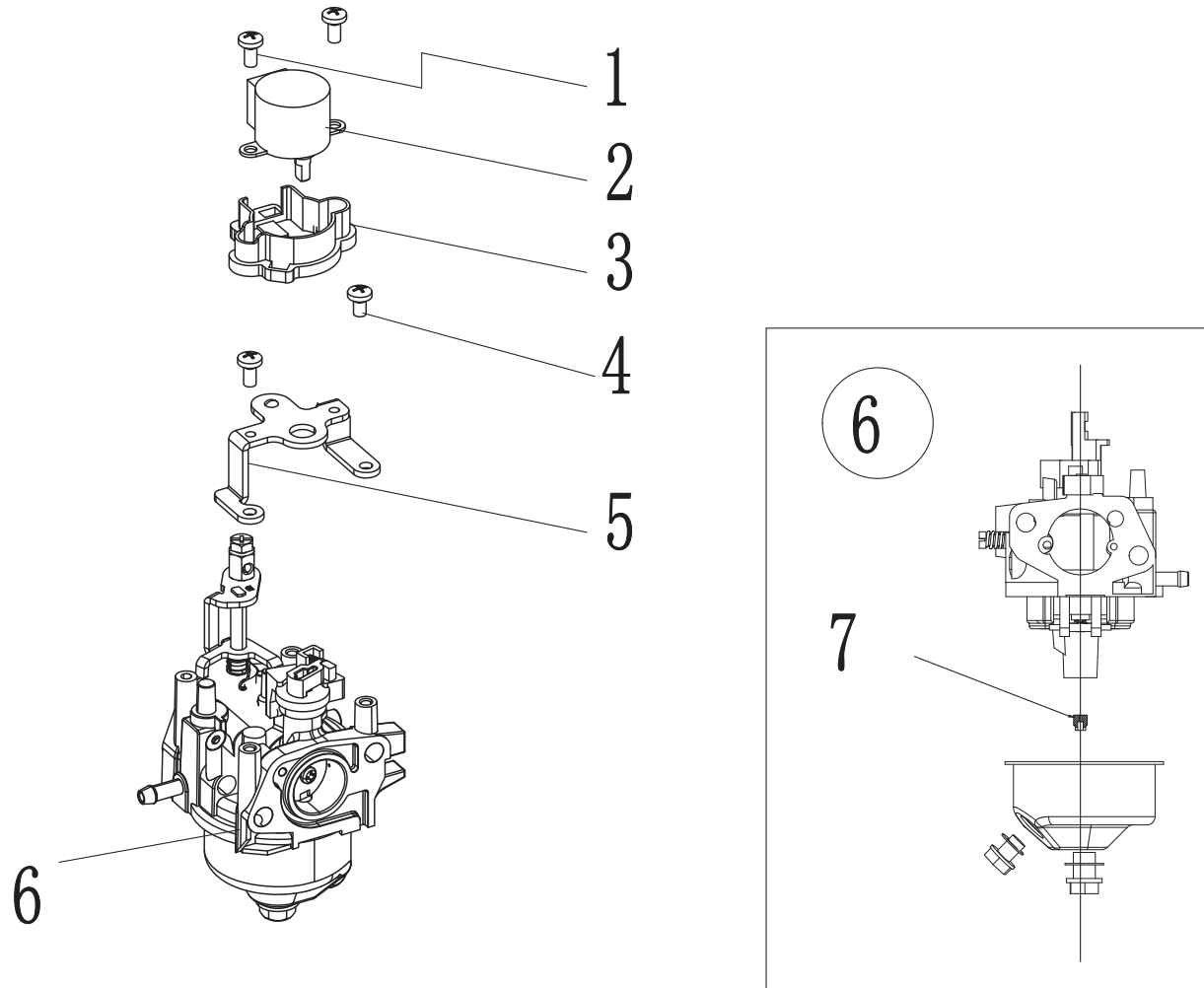

Figure D

CARBURETOR PARTS LIST

#	Part Number	Description	Qty.
1	1.823.0408.1	Screw M4 x 8	2
2	62.132200.00	Stepper Motor	1
3	85.132100.04	Support, Stepper Motor	1
4	1.9074.3.0408	Screw M4 x 8	4
5	85.130005.04	Support, Stepper Motor	1
6	63.131000.00	Carburetor	1
7	63.131017.00	Standard Main Jet	1
	63.131017.00.01	Altitude Main Jet	/

FUEL TANK PARTS DIAGRAM

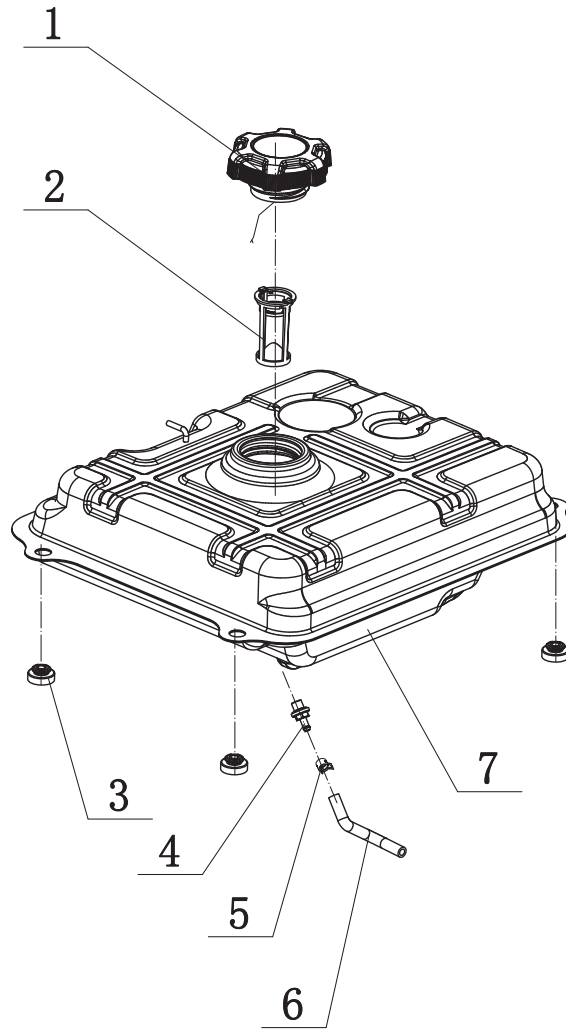

Figure F

FUEL TANK PARTS LIST

#	Part Number	Description	Qty.
1	122.070100.09	Fuel Tank Cap	1
2	63.070300.00	Fuel Filter, Fuel Pipe	1
3	63.070015.00	Mount Vibration, Fuel Tank	4
4	63.070600.00	Connect	1
5	2.06.018	Clamp, Ø10.5 x b8	1
6	63.070011.00	Fuel Pipe, Fuel Tank To Fuel Valve	1
7	63.071000.01.1	Fuel Tank	1

CONTROL PANEL PARTS DIAGRAM

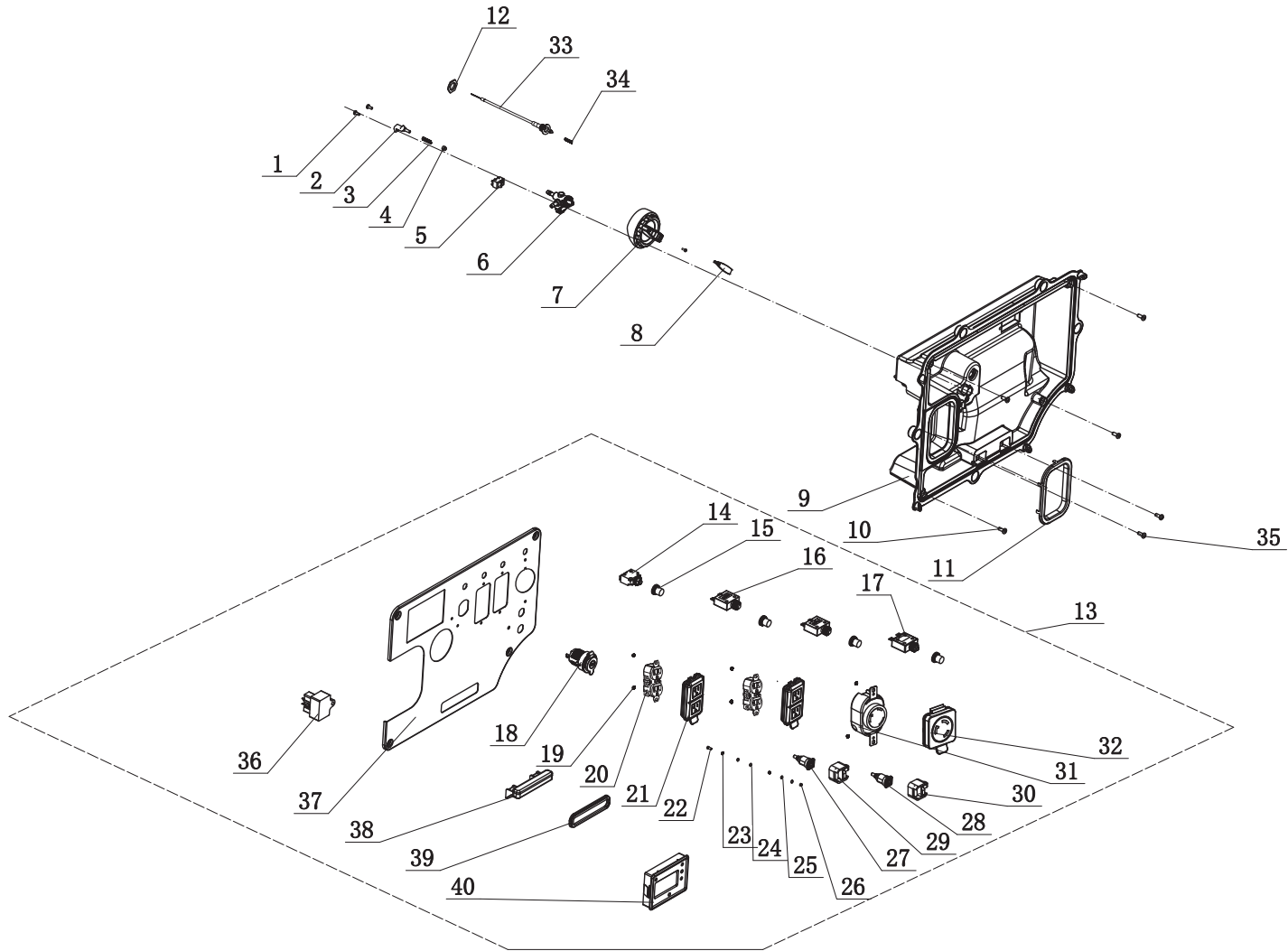

Figure G

CONTROL PANEL PARTS LIST

#	Part Number	Description	Qty.
1	1.823.0412.1	Screw M4×12	3
2	62.139006.00	Pressure Plate	1
3	62.139007.00	Spring, Steel Ball	1
4	62.139008.00	Ball Bearing, Rotary Knob	1
5	5.1050.006	Microswitch	1
6	63.070400.00	Fuel Valve	1
7	62.139001.00	Rotary Knob	1
8	62.139002.00.48	Cover, Rotary Knob	1
9	63.210002.02	Control Box, CSA	1
10	1.9074.4.0512.1	Screw/Washer Assembly M5 x 12, Black	4
11	63.200106.00	Protector, Front Cover	1
12	2.02.036	Thin Hexnut M16 x 1.5	1
13	201242.21	Control Panel	1
14	5.1200.908	8 Amp Circuit Breaker, Push Button	1
15	5.1870.014	Circuit Breaker Cover, Push Button	4
16	5.1210.920	20 Amp Circuit Breaker, Push Button	2
17	5.1210.930	30 Amp Circuit Breaker, Push Button	1
18	5.1110.005	Receptacle, DC12V	1
19	1.6177.1.04.1	Lock Nut M4, Flange	6
20	5.1120.027	Receptacle 5-20R, Duplex,CSA	2
21	5.1870.025	Receptacle Cover, Receptacle 5-20R, Duplex	2
22	1.5783.0520.1	Bolt M5 x 20, Black	1
23	1.862.05	Lock Washer Ø5, Toothed	1
24	1.93.05.1	Lock Washer Ø5, Black	2
25	1.97.1.05.1	Washer Ø5, Black	2
26	1.6170.05.1	Nut M5	2
27	83.210001.01.1	Connect Port, Black	1
28	83.210001.01.3	Connect Port, Red	1
29	5.1870.032	Cover, Connect Port, 125V/25A, Black	1
30	5.1870.032.3	Cover, Connect Port, 125V/25A, Red	1

#	Part Number	Description	Qty.
31	5.1120.023	Receptacle L5-30	1
32	5.1870.023	Receptacle Cover, Receptacle L5-30	1
33	63.130200.00	Pull Choke Assembly	1
34	62.130201.00	Spring, Pull Choke	1
35	1.818.0514.1	Screw M5×14	2
36	5.1830.027	Module, Indicator Light	1
37	63.01.8.48	Control Panel	1
38	63.214000.01	Indicator Light Assembly, Control Panel	1
39	63.213004.00	Indicator Light Assembly Cover	1
40	63.210017.04	Multifunction Display (2N)	1

FRAME ASSEMBLY PARTS DIAGRAM

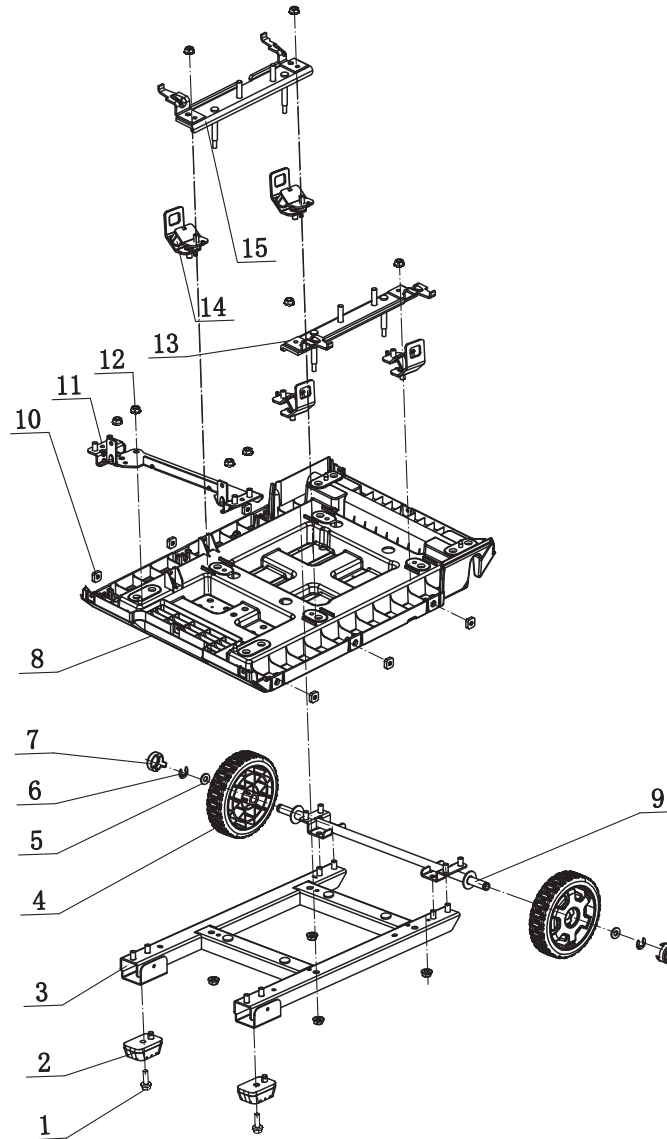
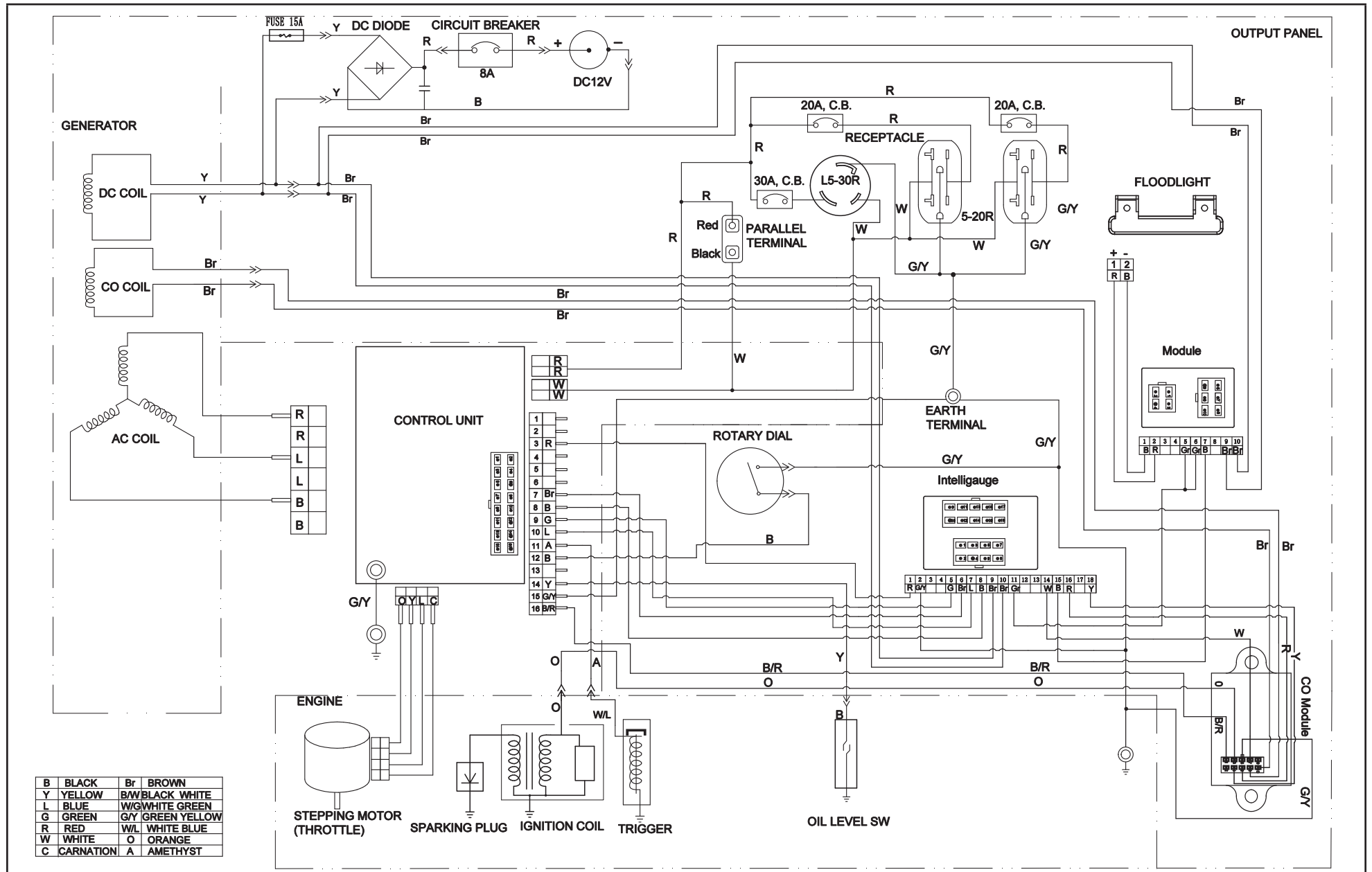

Figure H

FRAME ASSEMBLY PARTS LIST

#	Part Number	Description	Qty.
1	1.5789.0615	Flange Bolt M6 x 15	2
2	63.201400.00	Rubber Pad	2
3	63.201100.00	Base Setting Component	1
4	83.201701.03.48	5.5 in. Wheel, Yellow	2
5	1.848.12	Washer Ø12	2
6	1.894.1.12	Retaining Ring, Ø12	2
7	83.201702.03.48	Plug, Wheel, Yellow	2
8	63.200601.01	Base Setting,CSA	1
9	63.201500.00	Axle	1
10	2.02.014	Nut M6, Square	6
11	63.201600.02	Supporter	1
12	1.6177.1.08	Lock Nut M8, Flange	12
13	63.201600.00	Supporter, Right	1
14	63.201200.00	Motor Mount	4
15	63.201600.01	Supporter, Left	1

WIRING DIAGRAM



B	BLACK	Br	BROWN
Y	YELLOW	B/W	BLACK WHITE
L	BLUE	W/G	WHITE GREEN
G	GREEN	G/Y	GREEN YELLOW
R	RED	W/L	WHITE BLUE
W	WHITE	O	ORANGE
C	CARNATION	A	AMETHYST