

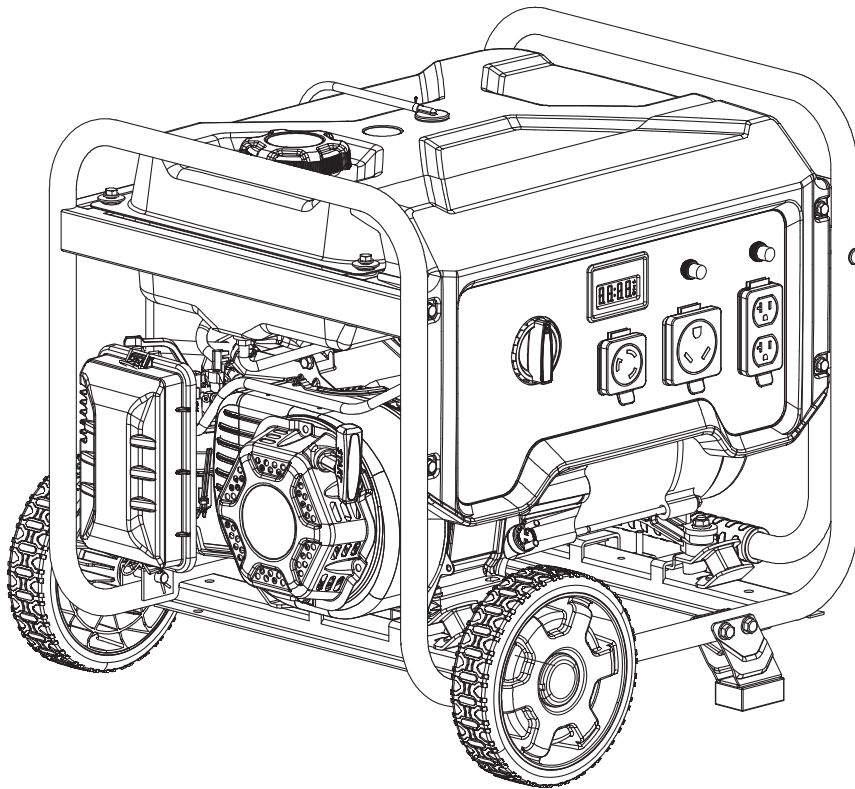

Champion Power Equipment, Inc., Santa Fe Springs, CA USA

MODEL #201070



PARTS INFORMATION

3650W PORTABLE GENERATOR

SERIAL NUMBER RANGE: ALL



To order replacement parts please visit:
shop.championpowerequipment.com
or call **1-877-338-0999**.

TABLE OF CONTENTS

Generator Parts Diagram	3
Generator Parts List	4
Engine Parts Diagram	5
Engine Parts Part List	6
Cylinder Head Diagram	8
Cylinder Head Part List	9
Alternator Diagram	10
Alternator Part List	11
Fuel Tank Diagram	12
Fuel Tank Part List	13
Control Panel Diagram	14
Control Panel Part List	15
Frame Assembly Diagram	16
Frame Assembly Part List	17
Wiring Diagram	18

GENERATOR PARTS DIAGRAM

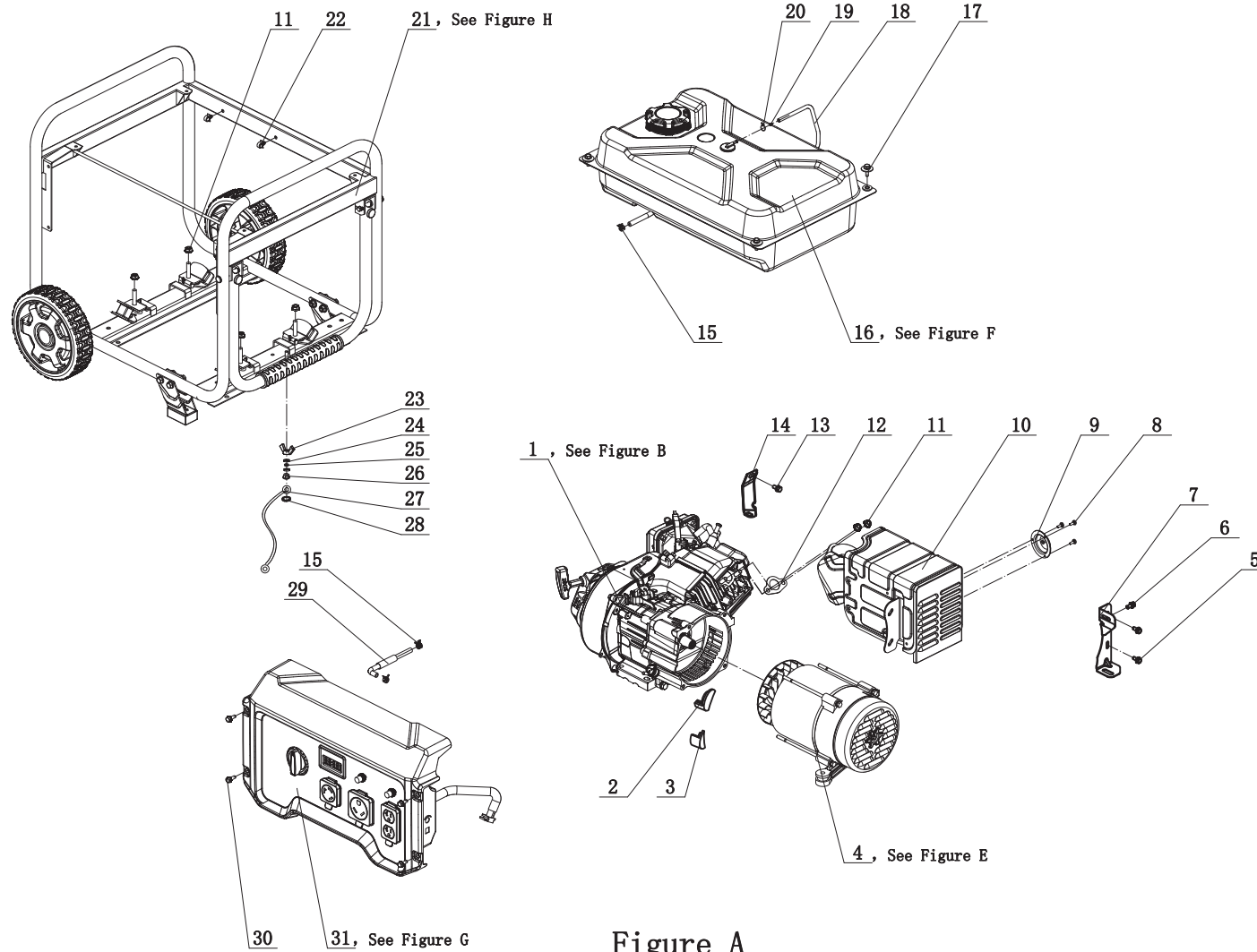

Figure A

GENERATOR PARTS LIST

#	Part Number	Description	Qty.
1	27.409.48	Engine, 224cc, See Figure B	1
2	122.190005.00	Rubber, Fore-Cover, B	1
3	122.190005.01	Rubber, Fore-Cover, A	1
4	124.190000.02	Alternator Assembly, See Figure E	1
5	1.5789.0620	Flange Bolt M6 x 20	2
6	1.5789.0615	Flange Bolt M6 x 15	1
7	27.100100.01	Bracket, Muffler	1
8	1.823.0406	Screw M4 x 6	3
9	27.101300.00	Spark Arrester	1
10	27.101000.04.2	Muffler Assembly, Black	1
11	1.6177.1.08	Lock Nut M8, Flange	6
12	26.100001.00	Gasket, Exhaust	1
13	1.5789.0608	Flange Bolt M6 x 8	1
14	23.090006.21	Bracket, Air Cleaner Support	1
15	2.06.007	Clamp Ø8.2 x b8	3
16	122.070000.66	Fuel Tank Assembly, See Figure F	1
17	2.08.143.1	Flange Bolt/Washer Assembly M6 x 20, Black	4
18	122.070014.02	Vent Tube, Reversal Valve, 670 mm	1
19	24.070030.00	Orifice, Breather Tube	1
20	2.06.006	Clamp Ø7 x Ø1	1
21	62402.201070	Frame Assembly, See Figure H	1
22	2.05.001	Clamp Ø8 x 6.5	2
23	1.62.06	Butterfly Type Nut M6	1
24	1.93.06.2	Lock Washer Ø6	1
25	1.97.1.06.2	Washer Ø6	2
26	1.6177.1.06	Lock Nut M6, Flange	1
27	5.1900.029	Grounding Line 150 mm	1
28	1.862.06	Lock Washer Ø6, Toothed	1
29	122.070011.24	Fuel Tube 390 mm, Fuel Valve to Carburetor	1
30	1.5789.0615.1	Flange Bolt M6 x 15, Black	4

#	Part Number	Description	Qty.
31	201070.21	Control Panel Assembly, See Figure G	1

ENGINE PARTS DIAGRAM

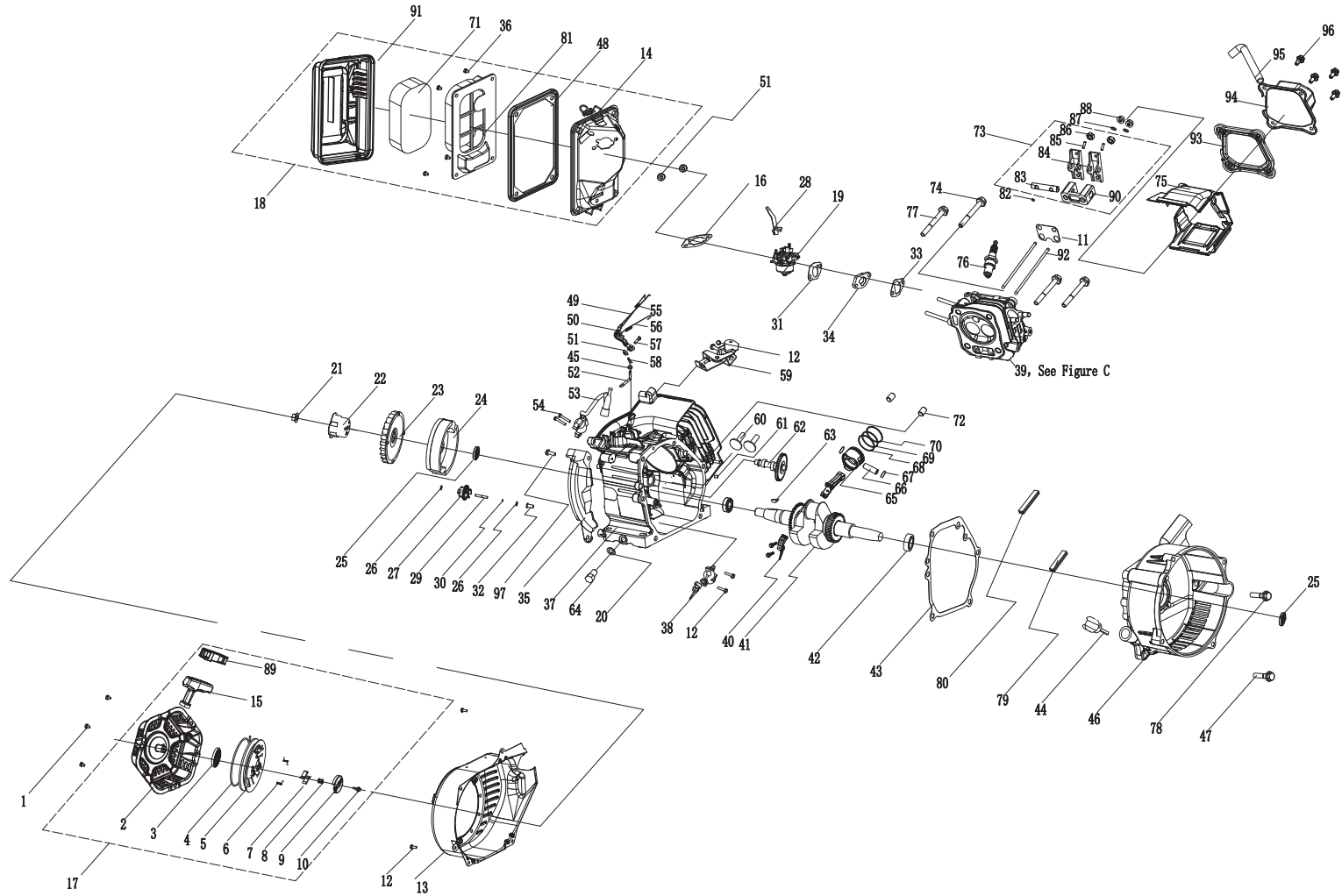

Figure B

ENGINE PARTS PART LIST

#	Part Number	Description	Qty.
1	1.5789.0608	Flange Bolt M6 x 8	3
2	27.061100.01.2	Cover, Recoil Starter, Black	1
3	21.061005.00	Spring, Recoil Starter	1
4	2.10.003.1	Rope Ø4 x 1550, Black	1
5	21.061001.01	Reel, Recoil Starter	1
6	45.060003.00	Spring, Ratchet	2
7	45.060002.00	Starter Ratchet, Steel	2
8	45.060009.00	Spring, Ratchet Guide	1
9	45.060007.00	Ratchet Guide	1
10	45.060008.00	Screw, Ratchet Guide	1
11	24.040004.00	Guide Plate, Push Rod	1
12	1.5789.0612	Flange Bolt M6 x 12	8
13	27.080100.07.48	Fan Cover, Yellow	1
14	24.091100.21	Base, Air Cleaner	1
15	21.061006.02	Handle, Recoil, Soft	1
16	24.130004.20	Gasket, Air Cleaner	1
17	27.061000.01	Recoil Assembly	1
18	27.091000.04	Air Cleaner Assembly	1
19	27.131000.01	Carburetor	1
20	2.03.016	Washer Ø10 x Ø16 x 1.5, Drain Bolt	1
21	2.02.006	Nut M14 x 1.5	1
22	23.060001.01	Pulley, Starter	1
23	27.080001.00	Fan, Engine Cooling	1
24	24.120100.06	Flywheel	1
25	2.11.001	Oil Seal Ø25 x Ø41.3 x 6	2
26	2.03.020.1	Washer Ø6.2 x Ø15 x 0.5, Black	2
27	21.110100.00	Gear, Governor	1
28	23.130100.20	Choke Lever	1
29	21.110013.00	Shaft, Governor Gear	1
30	21.110011.00	Clip, Governor Gear	1

#	Part Number	Description	Qty.
31	22.130003.00	Gasket, Carburetor	1
32	21.110012.01	Bushing, Governor Gear, Steel	1
33	24.130002.00	Gasket, Insulator	1
34	27.130001.00	Insulator, Carburetor	1
35	23.080600.00	Air Guide, Right Side	1
36	2.08.166	Flange Bolt M5x12	4
37	27.030100.01	Crankcase	1
38	21.127000.02	Oil Level Sensor	1
39	27.010000.00	Cylinder Head Assembly, See Figure C	1
40	27.050200.00	Connecting Rod	1
41	27.050100.00	Crankshaft	1
42	1.276.6205	Bearing 6205	2
43	24.030008.00	Gasket, Crankcase Cover	1
44	22.031000.00.48	Oil Dipstick, Yellow	1
45	2.03.021.1	Washer Ø6.4 x Ø13 x 1, Black	1
46	27.030007.01	Cover, Crankcase	1
47	1.5789.0832	Flange Bolt M8 x 32	5
48	23.091002.21	Seal, Air Cleaner	1
49	23.110006.00	Rod, Governor	1
50	27.110003.00	Arm, Governor	1
51	1.6177.06	Flange Nut M6	3
52	21.110001.00	Shaft, Governor Arm	1
53	22.123000.02	Ignition Coil	1
54	1.5789.0625	Flange Bolt M6 x 25	2
55	23.110005.01	Spring, Throttle Return	1
56	23.110007.00	Spring, Governor	1
57	2.08.040	Bolt M6x21, Governor Arm	1
58	21.110008.00	Pin, Shaft	1
59	27.111000.20	Governor Speed Control	1
60	25.040013.00	Lifter, Valve	2

#	Part Number	Description	Qty.
61	2.04.001	Dowel Pin Ø9 x 14	2
62	27.041000.00	Camshaft	1
63	2.14.012	Woodruff Key, 4 x 7.5 x 19	1
64	2.08.037	Drain Bolt M10 x 1.25 x 25	1
65	27.050005.00	Piston	1
66	23.050003.00	Pin, Piston	1
67	2.09.001	Circlip Ø18 x Ø1	2
68	27.050303.00	Ring, Oil	1
69	27.050302.00	Ring, Second Piston	1
70	27.050301.00	Ring, First Piston	1
71	23.091003.21	Element, Air Cleaner	1
72	2.04.003	Dowel Pin Ø10 x 14	2
73	24.040200.00	Rocker Arm Assembly	1
74	2.08.121	Flange Bolt M10 x 65	1
75	27.080200.00	Air Shroud, Cylinder	1
76	2.15.002(F6RTC)	Spark Plug F6RTC	1
77	1.5789.0865	Flange Bolt M8 x 65	3
78	1.5789.0840	Flange Bolt M8 x 40	1
79	27.030013.01	Seal Strip, Crankcase Cover, Short	1
80	27.030013.00	Seal Strip, Crankcase Cover, Long	1
81	23.091001.21	Separator, Air Cleaner	1
82	21.040008.00	Rotator, Exhaust Valve	1
83	24.040202.00	Shaft, Rocker Arm	1
84	22.040009.00	Rocker Arm	2
85	22.040012.00	Screw, Valve Adjustment	2
86	21.040021.00	Nut M6 x 0.5, Lock	2
87	1.97.1.06	Washer Ø6	2
88	1.6177.1.06	Flange Nut M6	2
89	21.061301.01.48	Insert, Recoil Handle	1
90	24.040201.00	Retainer, Rocker Arm	1
91	27.091200.04	Cover, Air Cleaner	1
92	27.040005.00	Push Rod	2

#	Part Number	Description	Qty.
93	21.020002.01	Gasket, Cylinder Head Cover	1
94	24.021000.00	Cover, Cylinder Head	1
95	23.020001.02	Breather Tube, 112 + 35 mm	1
96	1.5789.0615	Flange Bolt M6 x 15	4
97	1.5789.0620	Flange Bolt M6 x 20	1

CYLINDER HEAD DIAGRAM

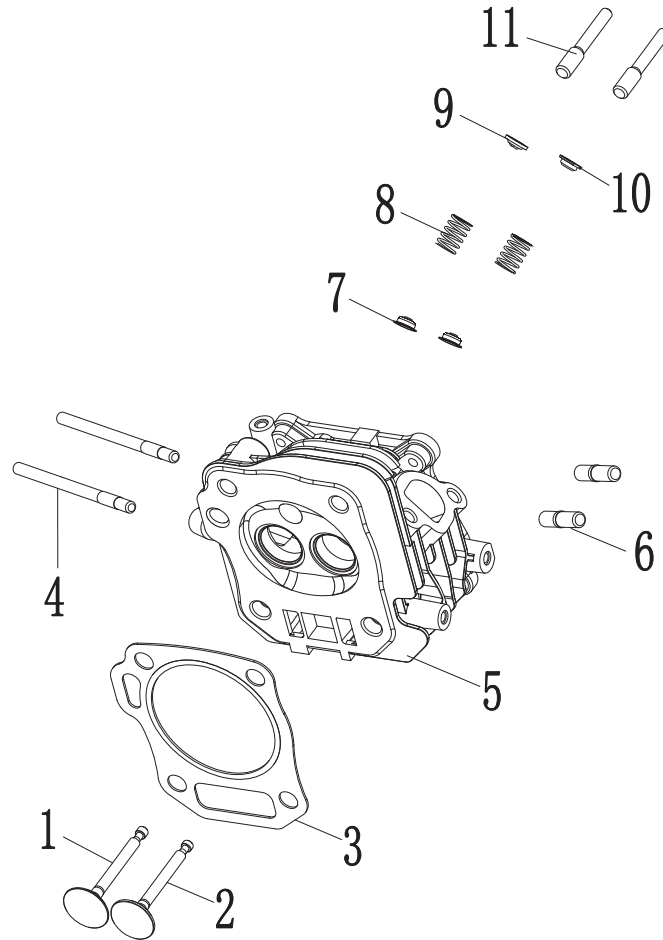

Figure C

CYLINDER HEAD PART LIST

#	Part Number	Description	Qty.
1	23.040002.02	Valve, Intake	1
2	23.040006.02	Valve, Exhaust	1
3	27.030009.01	Gasket, Cylinder Head	1
4	2.01.003	Stud Bolt M6 x 90	2
5	26.010100.01	Cylinder Head, 224cc	1
6	2.01.010	Stud Bolt M8 x 35	2
7	23.040017.00	Oil Seal, Valve, Steel	2
8	21.040003.00	Spring, Valve	2
9	21.040001.00	Retainer, Intake Valve Spring	1
10	21.040007.00	Retainer, Exhaust Valve Spring	1
11	23.040010.00	Bolt, Rocker Arm	2

ALTERNATOR DIAGRAM

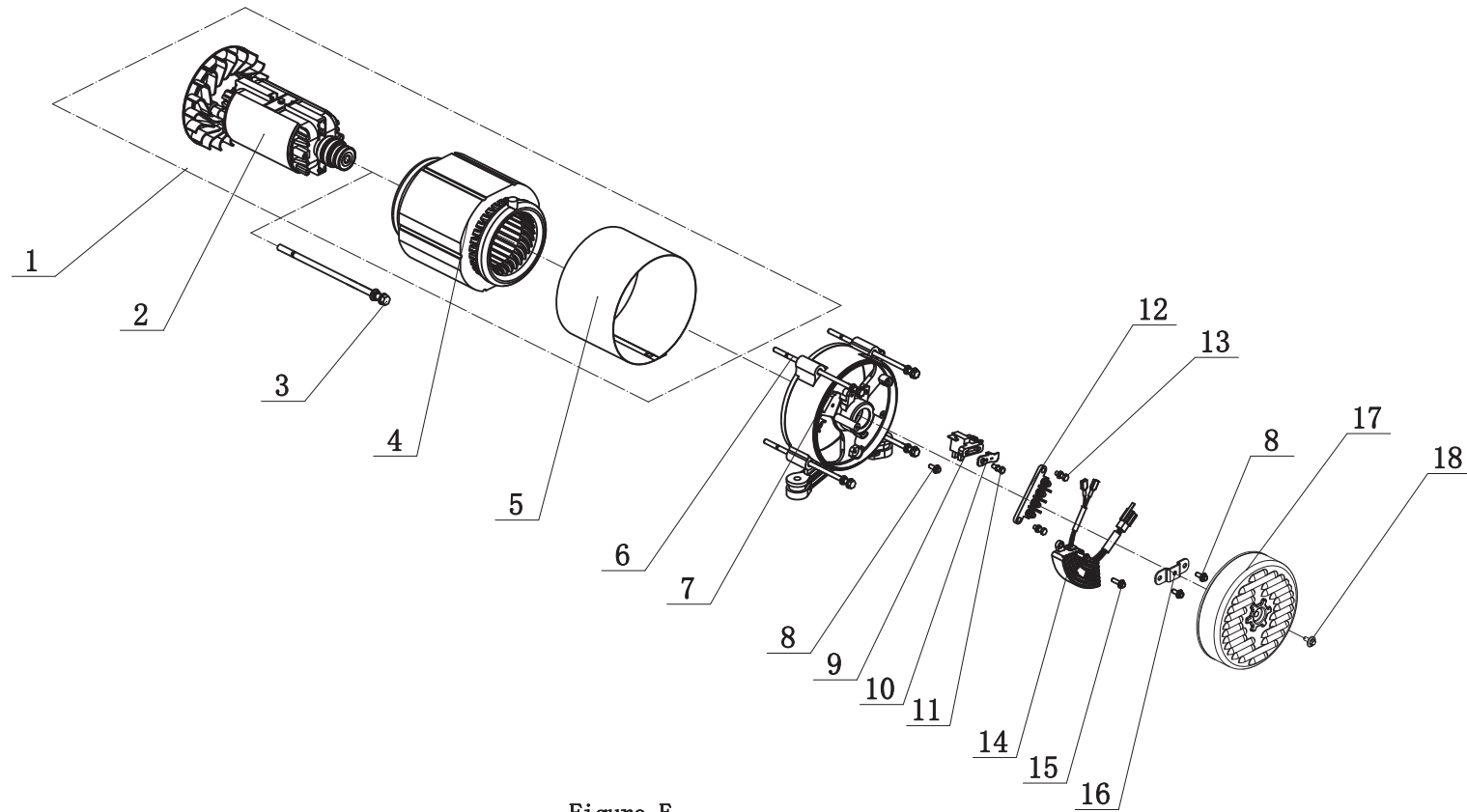

Figure E

ALTERNATOR PART LIST

#	Part Number	Description	Qty.
1	124.191000.02	Alternator Assembly, Al, Ø160 x 130 mm, CSA	1
2	124.191100.02	Rotor Assembly, Al, Ø160 x 130 mm, CSA	1
3	2.08.109	Flange Bolt/Washer Assembly M8 x 252	1
4	124.191200.02	Stator Assembly, Al, Ø160 x 130 mm, CSA	1
5	124.191002.01	Stator Cover	1
6	2.08.032	Flange Bolt/Washer Assembly M6 x 179	4
7	122.190002.00	End Housing	1
8	1.16674.0512.2	Flange Bolt M5 x 12	3
9	122.190300.00	Carbon Brush Assembly	1
10	122.190004.01	Bracket, Carbon Brush Retaining	1
11	1.9074.15.0520	Bolt/Washer Assembly M5 x 20	1
12	122.190400.02	Terminal Block	1
13	1.9074.17.0516	Screw/Washer Assembly M5 x 16	2
14	122.190200.03	AVR	1
15	1.16674.0516	Flange Bolt M5 x 16	2
16	122.190018.03	Bracket, End Housing Cover Mounting	1
17	122.190003.01.48	Cover, End Housing, Yellow	1
18	2.08.068.1	Flange Bolt M5 x 13, Black	1

FUEL TANK DIAGRAM

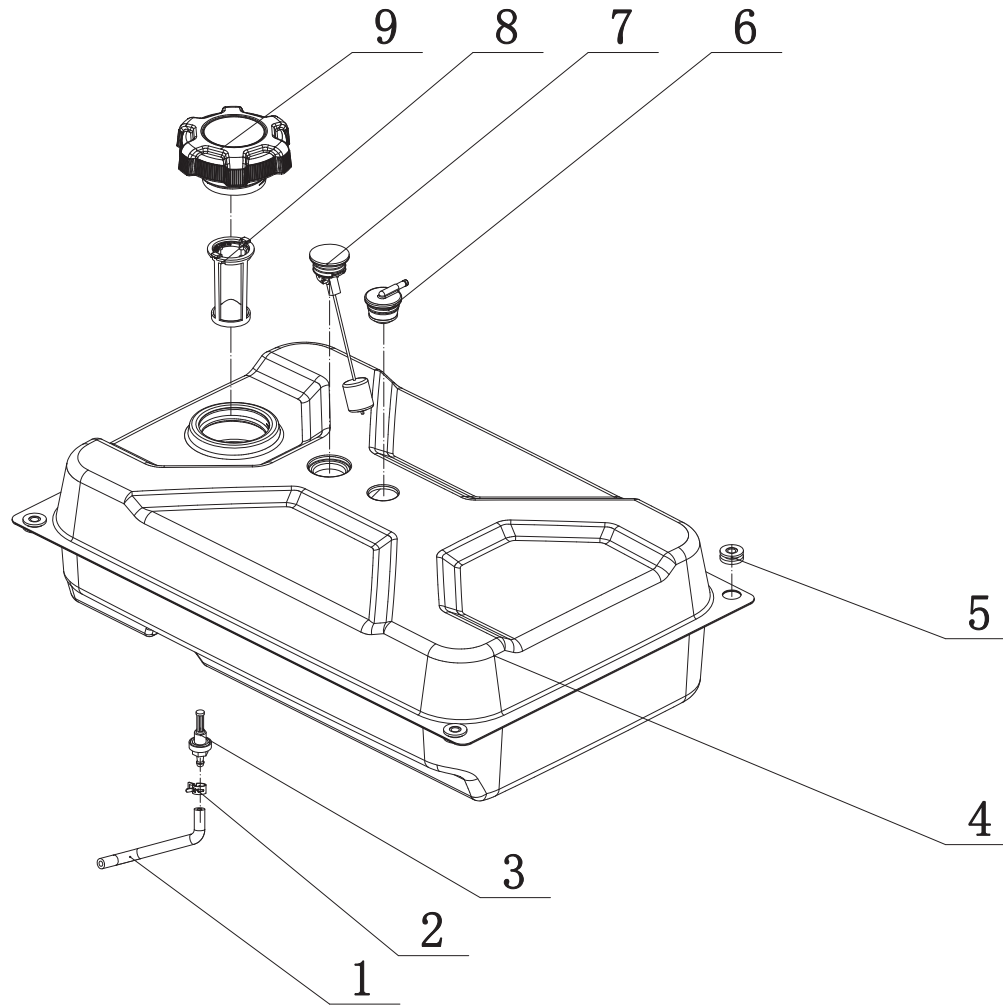

Figure F

FUEL TANK PART LIST

#	Part Number	Description	Qty.
1	122.070011.23	Fuel Tube 240 mm, Fuel Tank to Fuel Valve	1
2	2.06.007	Clamp Ø8.2 x b8	1
3	21.070600.04	Fitting, Fuel Tank with Filter	1
4	122.071000.66.48	Fuel Tank, 17.8L, Yellow	1
5	122.070015.01	Mount Vibration, Fuel Tank	2
6	24.070800.00	Valve, Reversal	1
7	122.072000.03	Fuel Gauge	1
8	122.070300.03	Fuel Filter	1
9	122.070100.09	Fuel Tank Cap	1

CONTROL PANEL DIAGRAM

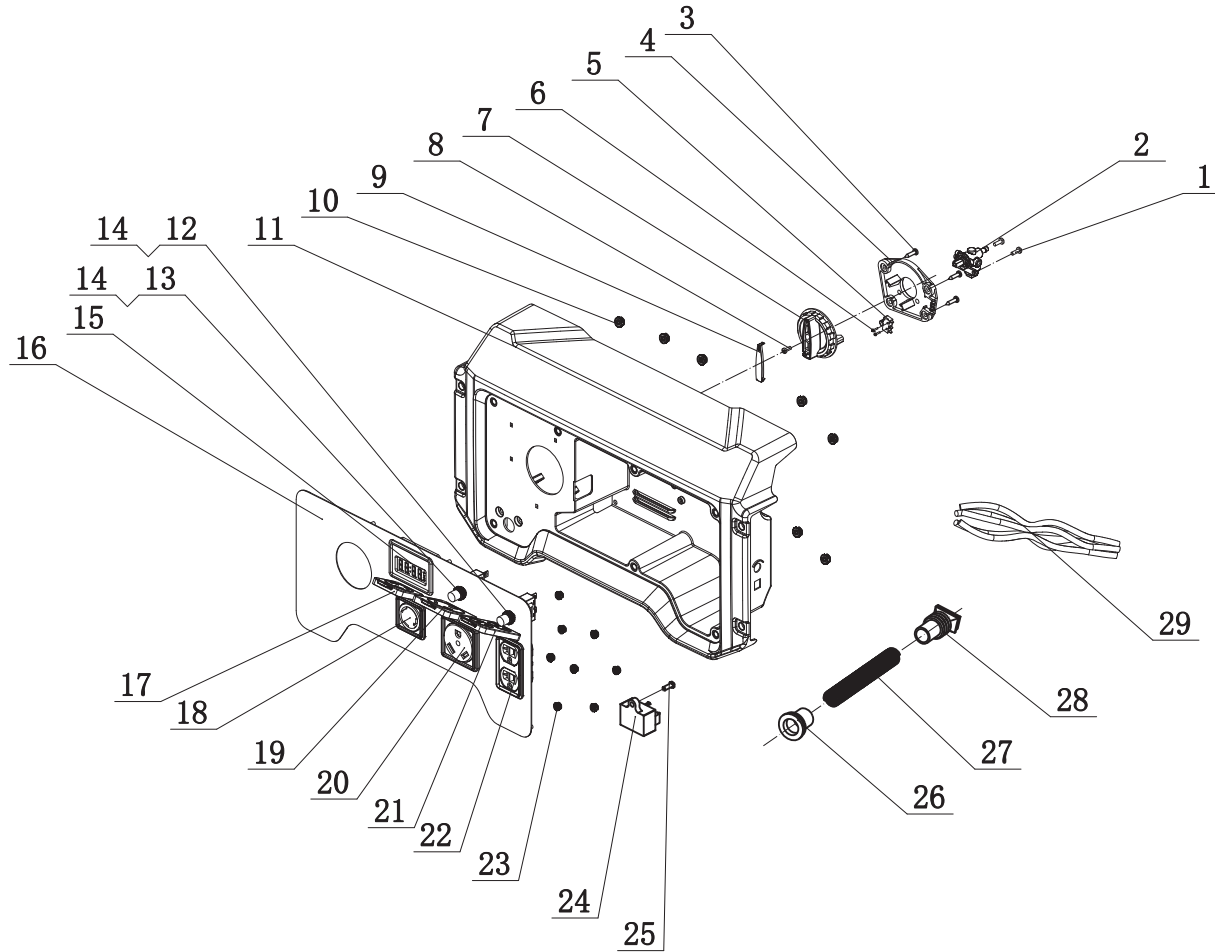

Figure G

CONTROL PANEL PART LIST

#	Part Number	Description	Qty.
1	1.818.0410	Screw M4 x 10	2
2	62.070400.00	Fuel Valve	1
3	1.845.4816	Screw, ST4.8 x 16	4
4	122.139004.01	Plate, Fuel Valve Mounting	1
5	5.1050.005	Microswitch	1
6	1.845.0.2210	Screw, ST2.2 x 10	2
7	122.139001.01	Fuel Dial	1
8	1.9074.4.0414.1	Screw/Washer Assembly M4 x 14, Black	1
9	62.139002.00.48	Insert, Fuel Dial, Yellow	1
10	1.6177.1.05	Lock Nut M5, Flange	7
11	122.210002.64	Control Panel Housing	1
12	5.1210.920	20Amp Circuit Breaker, Push Button, CSA	1
13	5.1210.930	30Amp Circuit Breaker, Push Button, CSA	1
14	5.1870.014	Circuit Breaker Cover, Push Button	2
15	5.1470.005	Intelligauge, INT1BOF	1
16	122.25.2.2	Control Panel	1
17	5.1870.023	Cover, Receptacle L5-30R	1
18	5.1120.023	Receptacle L5-30R, CSA	1
19	5.1870.021	Cover, Receptacle TT-30R	1
20	5.1120.036	Receptacle TT-30R	1
21	5.1870.025	Cover, Receptacle 5-20R	1
22	5.1120.027	Receptacle 5-20R, Duplex, CSA	1
23	1.6177.1.04.1	Lock Nut M4, Flange, Black	8
24	5.1810.000	Over Voltage Protector, CSA	1
25	1.818.0514.2	Screw M5 x 14	1
26	122.210003.02	Gromet, Control Panel Housing, CSA	1
27	5.1320.012	Sheath, Wire Harness, CSA	1
28	122.210003.04	Gromet, End Cover, CSA	1
29	201070.21.10	Wire Harness	1

FRAME ASSEMBLY DIAGRAM

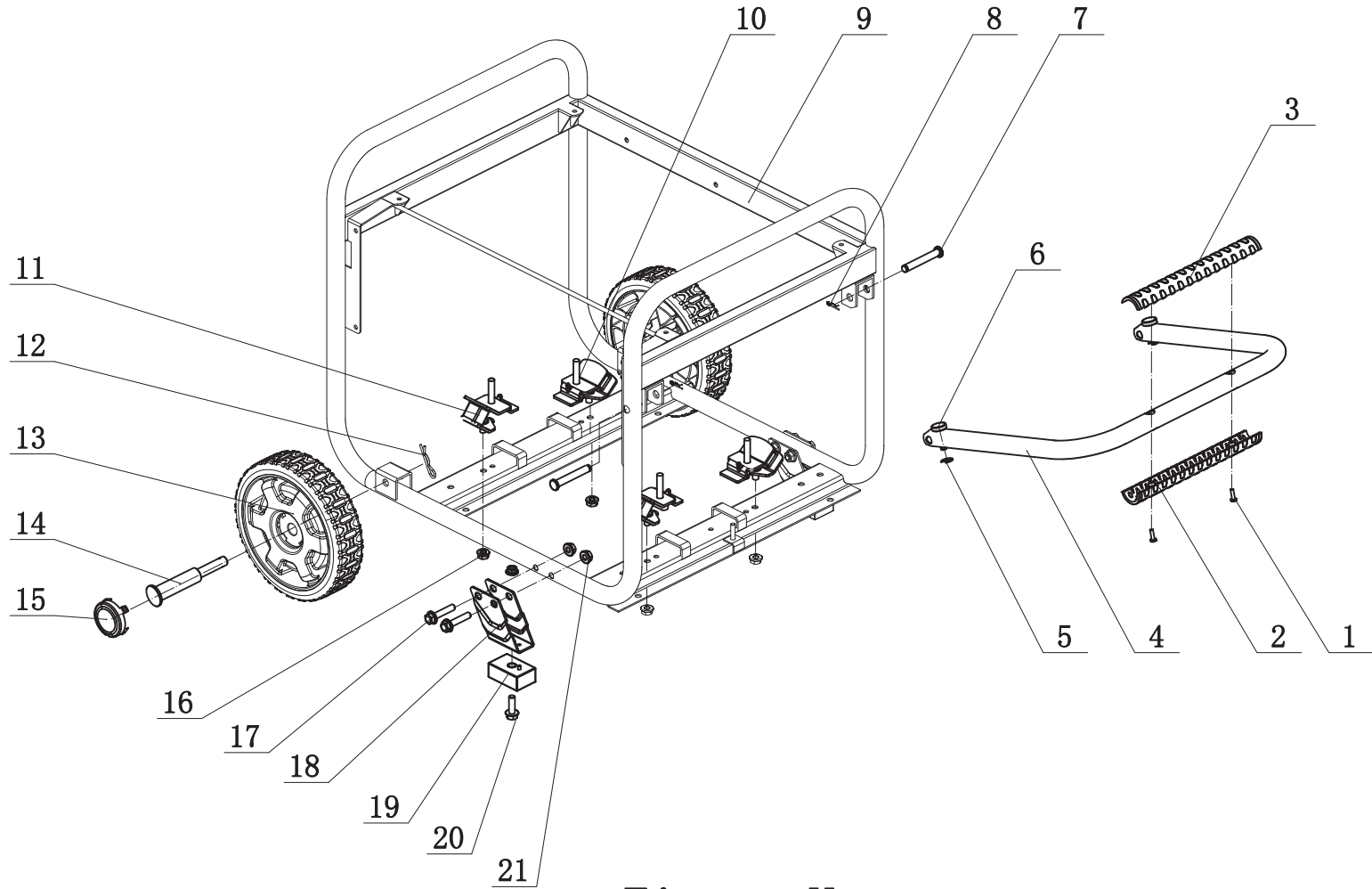

Figure H

FRAME ASSEMBLY PART LIST

#	Part Number	Description	Qty.
1	1.9074.4.0414.1	Screw/Washer Assembly M4 x 14, Black	2
2	122.200702.13	Cover, Handle, Upper	1
3	122.200702.14	Cover, Handle, Lower	1
4	122.200701.13	Handle, U Style	1
5	1.894.1.08	Circlip Ø8	2
6	152.200703.02	Short Pin, Handle	2
7	152.200703.05	Long Pin, Handle	2
8	11.110008.00	Pin, "R" Shape	2
9	62402.09.16.2	Frame, 590 x 492 x 502mm	1
10	122.201200.07	Motor Mount 2	2
11	122.201200.06	Motor Mount 1	2
12	2.16.001.1	Pin Ø2 x 33, "R" Shape, Black	2
13	122.201701.11.48	8 in. Wheel, PU, Yellow	2
14	122.201501.23.1	Pin Roll, Wheel, Ø16 x Ø10 x 97, Black	2
15	122.201702.11.48	Wheel Cover, Tooth Profile 8-10 in, Yellow	2
16	1.6177.1.08	Lock Nut M8, Flange	4
17	1.5789.0840.1	Flange Bolt M8 x 40, Black	4
18	152.200002.16.2	Support Leg, 68 mm	2
19	122.201400.04	Rubber, Support	2
20	1.5789.0825.1	Flange Bolt M8 x 25, Black	2
21	1.6177.1.08.1	Lock Nut M8, Flange, Black	6

WIRING DIAGRAM

