



OPERATOR'S MANUAL

MODEL #100250

37 TON FULL BEAM LOG SPLITTER



REGISTER YOUR PRODUCT ONLINE

at championpowerequipment.com

SERIAL NO. LABEL



1-877-338-0999

or visit championpowerequipment.com

READ AND SAVE THIS MANUAL. This manual contains important safety precautions which should be read and understood before operating the product. Failure to do so could result in serious injury. This manual should remain with the product.

Specifications, descriptions and illustrations in this manual are as accurate as known at the time of publication, but are subject to change without notice.

TABLE OF CONTENTS	
Introduction	3
Safety Definitions	3
Important Safety Instructions	4
Fuel Safety	5
Training	6
Preparation	6
Operation	7
Maintenance and Storage	7
Safety and Dataplate Labels	8
Safety Symbols	9
Operation Symbols	11
Quickstart Label Symbols	11
Controls and Features	12
Log Splitter	12
Engine	13
Parts Included	14
Parts Not Included	14
Assembly	15
Open Shipping Crate	15
1) Install the Hydraulic Oil Filter	15
2) Install the Wheels	15
3) Install the Tow Bar	15
4) Install the Support Leg	16
5) Install the Beam	16
6) Install the Cylinder and Wedge	16
7) Install the Engine and Hoses	17
8) Install the Log Catchers	18
Add Engine Oil	18
Add Fuel	19
Add Hydraulic Oil	19
Operation	20
Before Each Use Inspect the Log Splitter	20
Changing Beam from Horizontal to Vertical Orientation	20
Towing Log Splitter Safety	20
Log Splitter Location	21
Starting the Engine	21
Stopping the Engine	22
Log Splitter Operation	22
Operation at High Altitude	23
Maintenance	23
Cleaning the Log splitter	23
Changing the Engine Oil	24
Cleaning and Adjusting the Spark Plug(s)	24
Cleaning the Air Filter	24
Changing the Hydraulic Oil and Oil Filter	24
Maintenance Schedule	25
Storage	26
Log Splitter Storage	26
Engine Stored for Less than 30 Days	26
Engines Stored for Over 30 Days	26
Specifications	27
Log Splitter Specifications	27
Engine Specifications	27
Oil Specifications	27
Hydraulic Oil System	27
Fuel Specifications	28
Spark Plug Specifications	28
Valve Specifications	28
Important Message About Temperature	28
Parts Diagram	29
Parts List	30
Engine Parts Diagram	31
Engine Parts List	32
Troubleshooting	34
Warranty*	35
Warranty Qualifications	35
Repair/Replacement Warranty	35
Do Not Return The Unit To The Place Of Purchase	35
Warranty Exclusions	35
Other Exclusions	35
Limits of Implied Warranty and Consequential Damage	35
Contact Information	35

INTRODUCTION

Congratulations on your purchase of a Champion Power Equipment (CPE) product. CPE designs, builds, and supports all of our products to strict specifications and guidelines. With proper product knowledge, safe use, and regular maintenance, this product should bring years of satisfying service.

Every effort has been made to ensure the accuracy and completeness of the information in this manual at the time of publication, and we reserve the right to change, alter and/or improve the product and this document at any time without prior notice.

Since CPE highly values how our products are designed, manufactured, operated and are serviced, and also highly value your safety and the safety of others, we would like you to take the time to review this product manual and other product materials thoroughly and be fully aware and knowledgeable of the assembly, operation, dangers and maintenance of the product before use. Fully familiarize yourself, and make sure others who plan on operating the product fully familiarize themselves too, with the proper safety and operation procedures before each use. Please always exercise common sense and always err on the side of caution when operating the product to ensure no accident, property damage, or injury occurs. We want you to continue to use and be satisfied with your CPE product for years to come.

When contacting CPE about parts and/or service, you will need to supply the complete model and serial numbers of your product. Transcribe the information found on your product’s nameplate label to the table below

CPE TECHNICAL SUPPORT TEAM
1-877-338-0999
MODEL NUMBER
100250
SERIAL NUMBER
DATE OF PURCHASE
PURCHASE LOCATION

SAFETY DEFINITIONS

The purpose of safety symbols is to attract your attention to possible dangers. The safety symbols, and their explanations, deserve your careful attention and understanding. The safety warnings do not by themselves eliminate any danger. The instructions or warnings they give are not substitutes for proper accident prevention measures.

⚠ DANGER

DANGER indicates a hazardous situation which, if not avoided, will result in death or serious injury.

⚠ WARNING

WARNING indicates a hazardous situation which, if not avoided, could result in death or serious injury.

⚠ CAUTION

CAUTION indicates a hazardous situation which, if not avoided, could result in minor or moderate injury.

🗨 NOTICE

NOTICE indicates information considered important, but not hazard-related (e.g., messages relating to property damaged).

IMPORTANT SAFETY INSTRUCTIONS

⚠ WARNING

Cancer and Reproductive Harm – www.P65Warnings.ca.gov

⚠ DANGER

Log splitter engine exhaust contains carbon monoxide, a colorless, odorless, poison gas. Breathing carbon monoxide will cause nausea, dizziness, fainting or death. If you start to feel dizzy or weak, get to fresh air immediately.

Operate log splitter outdoors only in a well ventilated area.

DO NOT operate the log splitter inside any building, including garages, basements, crawlspaces and sheds, enclosure or compartment.

DO NOT allow exhaust fumes to enter a confined area through windows, doors, vents or other openings.

⚠ DANGER

Using an engine indoors **CAN KILL YOU IN MINUTES**. Engine exhaust contains carbon monoxide. This is a poison you cannot see or smell.

NEVER use inside a home or garage, **EVEN IF** doors and windows are open.

ONLY use **OUTSIDE** and far away from windows, doors, and vents.

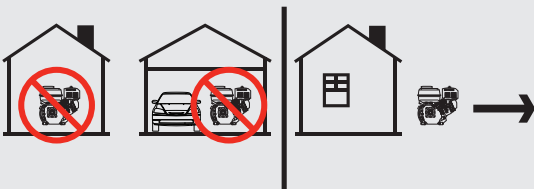

Install battery-operated carbon monoxide alarms or plug-in carbon monoxide alarms with battery back-up according to the manufacturer’s instructions.

⚠ DANGER

Rotating parts can entangle hands, feet, hair, clothing and/or accessories. Traumatic amputation or severe laceration can result.

Keep hands and feet away from rotating parts.

Tie up long hair and remove jewelry.

Operate equipment with guards in place.

DO NOT wear loose-fitting clothing, dangling drawstrings or items that could become caught.

⚠ WARNING

Operation of this equipment may create sparks that can start fires around dry vegetation.

A spark arrestor may be required. The operator should contact local fire agencies for laws or regulations relating to fire prevention requirements.

⚠ WARNING

Sparks can result in fire or electrical shock.

When servicing the engine:

Disconnect the spark plug wire and place it where it cannot contact the plug.

DO NOT check for spark with the plug removed.

Use only approved spark plug testers.

⚠ WARNING

Running engines produce heat. Severe burns can occur on contact. Combustible material can catch fire on contact.

DO NOT touch hot surfaces.

Avoid contact with hot exhaust gases.

Allow equipment to cool before touching.

Maintain at least 3 ft. (91.4 cm) of clearance on all sides to ensure adequate cooling.

Maintain at least 5 ft. (1.5 m) of clearance from combustible materials.

⚠ WARNING

Crush Hazard

Wedge can cut through skin and break bones. Keep all limbs away from wedge and endplate.

⚠ WARNING

Projectile Hazard

Pieces of log may be ejected from the splitter while operating. Wear ANSI approved safety glasses when operating. Be alert.

⚠ WARNING

Keep Operator Work Zone Clear

Keep work zone clear of debris while working to ensure safe footing.

⚠ WARNING

Before removing the pin installed into the front support leg make sure hitch is installed onto vehicle. Releasing the pin before will cause support leg to slide up and possibly cause injury.

⚠ WARNING

Skin Injection Hazard. High pressure hydraulic oil can inject under your skin.

Make sure all fittings are tightly secure before applying pressure. Relieve system of pressure before servicing.

⚠ WARNING

Towing Hazard

ALWAYS check all local and state regulations regarding towing, licensing and lights before towing your log splitter. Review towing safety warnings in your towing vehicle manual.

Drive safely. Be aware of the added length of the log splitter. NEVER ride or transport cargo on the log splitter. Choose a level surface to operate the log splitter.

NEVER EXCEED MAX. Towing Speed 45 MPH (72 KM/H)

⚠ WARNING

Rapid retraction of the starter cord will pull hand and arm towards the engine faster than you can let go. Unintentional startup can result in entanglement, traumatic amputation or laceration. Broken bones, fractures, bruises or sprains could result.

When starting engine, pull the starter cord slowly until resistance is felt and then pull rapidly to avoid kickback.

⚠ CAUTION

Parts of the hydraulic circuit (cylinder, pump, valve-body, hoses) can become very hot during operation.

⚠ WARNING

In most states towing on public streets is either prohibited or would require further licensing or modifications. Please check with your local authorities or DMV regarding regulations, restrictions and registration.

⚠ CAUTION

Improper treatment or use of the log splitter can damage it, shorten its life and void your warranty.

Use the log splitter only for intended uses.

Operate only on level surfaces.

DO NOT expose log splitter to excessive moisture, dust, or dirt.

DO NOT allow any material to block the cooling slots.

DO NOT use the engine if:

- Equipment sparks, smokes or emits flames
- Equipment vibrates excessively

Fuel Safety

⚠ DANGER

GASOLINE AND GASOLINE VAPORS ARE HIGHLY FLAMMABLE AND EXPLOSIVE.

Fire or explosion can cause severe burns or death.

Gasoline and gasoline vapors:

- Gasoline is highly flammable and explosive.
- Gasoline can cause a fire or explosion if ignited.
- Gasoline is a liquid fuel but its vapors can ignite.
- Gasoline is a skin irritant and needs to be cleaned up immediately if spilled on skin or clothes.
- Gasoline has a distinctive odor, this will help detect potential leaks quickly.
- In any petroleum gas fire, flames should not be extinguished unless by doing so the fuel supply valve can be turned OFF. This is because if a fire is extinguished and a supply of fuel is not turned OFF, then an explosion hazard could be created.
- Gasoline expands or contracts with ambient temperatures. Never fill the gasoline tank to full capacity, as gasoline needs room to expand if temperatures rise.

When adding or removing gasoline:

Turn the engine off and let it cool for at least two minutes before removing the gasoline cap. Loosen the cap slowly to relieve pressure in the tank.

Only fill or drain gasoline outdoors in a well-ventilated area.

DO NOT pump gasoline directly into the engine at the gas station. Use an approved container to transfer the fuel to the engine.

DO NOT overfill the gasoline tank.

Always keep gasoline away from sparks, open flames, pilot lights, heat and other sources of ignition.

DO NOT light or smoke cigarettes.

When starting the engine:

DO NOT attempt to start a damaged engine.

Make certain that the gasoline cap, air filter, spark plug, fuel lines and exhaust system are properly in place.

Allow spilled gasoline to evaporate fully before attempting to start the engine.

Make certain that the log splitter is resting firmly on level ground.

When operating the log splitter:

DO NOT move or tip the log splitter during operation.

DO NOT tip the log splitter or allow fuel or oil to spill.

When transporting or servicing the log splitter:

Make certain that the fuel valve is in the OFF position, the gasoline tank is empty.

Disconnect the spark plug wire.

When storing the log splitter:

Store away from sparks, open flames, pilot lights, heat and other sources of ignition.

Do not store log splitter or gasoline near furnaces, water heaters, or any other appliances that produce heat or have automatic ignitions.

WARNING

NEVER use a gasoline container, gasoline tank, or any other fuel item that is broken, cut, torn or damaged.

Training

1. Read the Operator's Manual completely before attempting to use this log splitter.
2. Do not allow anyone to operate your log splitter who has not read the Operator's Manual or has not been instructed on the safe use of the log splitter.
3. Never allow children or untrained adults to operate this machine.
4. Many accidents occur when more than one (1) person operates the log splitter. If a helper is assisting in loading logs to be split, never actuate controls until helper is clear of the area.
5. Never allow anyone to ride on the machine.
6. Never transport cargo on the log splitter.

7. High fluid pressures are developed in hydraulic log splitters. Pressurized hydraulic fluid escaping through a pin hole opening can puncture skin and cause severe blood poisoning. Therefore, the following instructions should be heeded at all times.
 - 7a. Do not operate the unit with frayed, kinked, cracked or damaged hoses, fittings, or tubing.
 - 7b. Stop the engine and relieve hydraulic system pressure before changing or adjusting fittings, hoses, tubing, or other system components.
 - 7c. Do not adjust the pressure settings of the pump or valve.
 - 7d. Do not check for leaks with your hand. Leaks can be detected by passing cardboard or wood over the suspected area. Look for discoloration. If injured by escaping fluid, see a doctor at once. Serious infection or reaction can develop if proper medical treatment is not administered immediately.
8. Keep the operator zone and adjacent area clear for safe, secure footing.
9. If your log splitter is equipped with an internal-combustion engine and intended for use near any unimproved forest, brush, or grass covered land, the engine exhaust should be equipped with a spark arrestor. Make sure you comply with local, state, and federal codes. Take appropriate fire-fighting equipment with you.
10. Log splitters should be used only for splitting wood. Do not use for other purposes unless the manufacturer provides attachments and instructions.
11. Only split wood WITH the grain. NEVER split perpendicular to the grain

Preparation

1. Be thoroughly familiar with all controls and with proper use of the equipment.
2. Safety Gear:
 - 2a. Always wear safety shoes or heavy boots when operating the machine.
 - 2b. Always wear safety glasses or goggles when operating the machine.
 - 2c. Never wear jewelry or loose-fitting clothing that might become entangled in moving or rotating parts of the machine.
3. Make sure the splitter is on a level surface. Block tires and ensure support leg is secure to prevent unintended movement of the log splitter during operation.
 - 3a. Always operate the splitter from the manufacturer's indicated operator zone.

4. Logs to be split on ram-type units should be cut as squarely as possible.
5. Fuel:
 - 5a. Use an approved fuel container.
 - 5b. Never add fuel to a running or hot engine.
 - 5c. Fill fuel tank outdoors with extreme care. Never fill fuel tank indoors.
 - 5d. Replace gasoline cap securely and clean up any spilled fuel.

Operation

1. Before starting this log splitter, review all safety rules. Failure to follow these rules may result in serious injury to the operator or bystanders.
2. Be sure to confirm all hose connections and hose clamps are tight before each use. It is possible for connections to vibrate loose over time.
3. Never leave the machine unattended with the power source operating.
4. Never operate the machine when under the influence of alcohol, drugs or medication.
5. The machine owner should instruct all operators in safe log splitter operation.
6. Always operate the log splitter with all safety equipment in place and all controls properly adjusted for safe operation.
7. Always operate the log splitter at manufacturer's recommended speed.
8. Always keep hands and feet clear of moving parts.
9. When loading a ram-type log splitter, place your hands on the sides of the log, not the ends. Never place your hands or any part of your body between a log and any part of the log splitter.
10. On ram-type log splitters, never attempt to split more than one (1) log at a time unless the ram has been fully extended and a second log is needed to complete the separation of the first log.
11. On ram-type log splitters on which the logs are not cut square, the longest portion of the log should be rotated down and the most square end placed against the ram.
12. Only split logs with the grain of the wood.
13. Use only your hand to operate the log splitter controls.
14. Do not refuel the engine until it has cooled for several minutes.

Maintenance and Storage

1. Always shut off the power source while repairing or adjusting the splitter except as recommended by the manufacturer.
2. Clean debris and chaff from the engine cylinder, cylinder head fins, recoil starter cover, and muffler areas. If the engine is equipped with a spark arrestor muffler, clean and inspect it regularly (follow manufacturer's service instructions). Replace, if damaged.
3. Never store the unit indoors with fuel in the tank. Fumes might reach an open flame spark. Allow the engine to cool before storing in any enclosure.
4. Clear debris from movable parts, but only when the power source is shut off.
5. Check to be sure all nuts and bolts are tight to assure the equipment is in safe working condition.

Safety and Dataplate Labels

These labels warn you of potential hazards that can cause serious injury. Read them carefully.

If a label comes off or becomes hard to read, contact Technical Support Team for possible replacement.

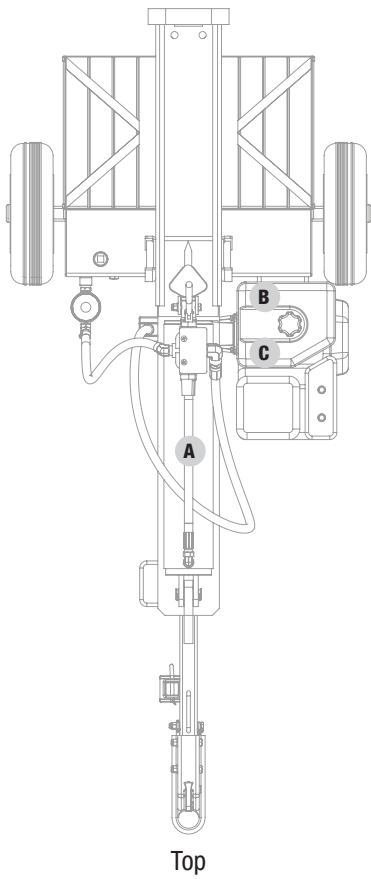

Top

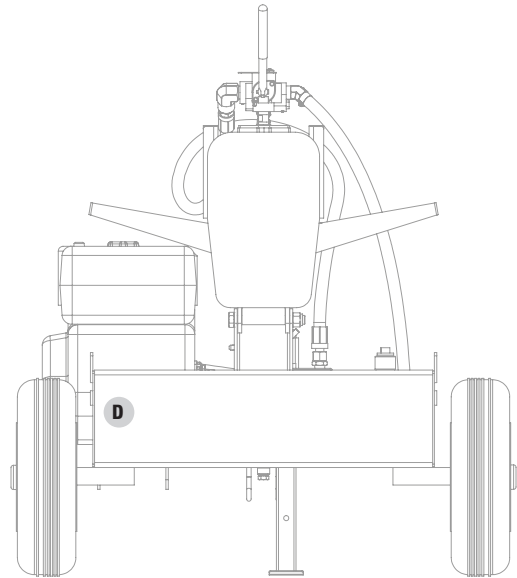













Back

	LABEL	DESCRIPTION
A		Safety Symbols
B		Fuel
C		Hot Surface
D		Dataplate

Safety Symbols

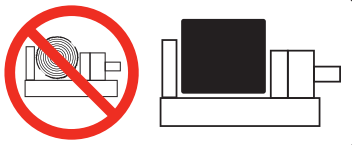
Some of the following symbols may be used on this product. Please study them and learn their meaning. Proper interpretation of these symbols will allow you to more safely operate the product.

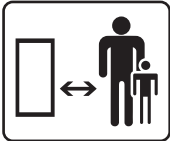
SYMBOL	MEANING
	<p>Read Operator's Manual. To reduce the risk of injury, user must read and understand operator's manual before using this product.</p>
	<p>Eye and Ear Protection. Always wear safety goggles or safety glasses with side shields, and as necessary a full face-shield as well as full ear protection when operating this product.</p>
	<p>Footwear. Always wear safety shoes or heavy boots when operating the machine.</p>
	<p>Gloves. Always wear nonslip, heavy-duty protective gloves when operating this product.</p>
	<p>Safety Alert. Precautions that involve your safety.</p>
	<p>Risk of Fire. Fuel and its vapors are extremely flammable and explosive. Fire can cause severe burns or death. Do not add fuel while the product is operating or still hot.</p>
	<p>Skin Injection Hazard. High pressure hydraulic oil can inject under your skin. Make sure all fittings are tightly secure before applying pressure. Relieve system pressure before servicing.</p>
	<p>Always keep hands away from the wedge and the ram. Moving parts can crush or cut.</p>

SYMBOL	MEANING
	<p>Always keep feet away from the wedge and the ram. Moving parts can crush or cut.</p>
	<p>Hot Surface. To reduce the risk of injury or damage, avoid contact with any hot surface</p>
	<p>Open Flame alert. Fuel and its vapors are extremely flammable and explosive. Keep fuel away from smoking, open flames, sparks, pilot lights, heat, and other ignition sources.</p>
	<p>Hold logs on sides when loading. Keep hands and feet away from cylinder, wedge, and partially split logs.</p>
	<p>Never place hands or any part of the body between a log and any part of the log splitter. Do not split logs against the grain. Split logs end to end in the direction of the grain only.</p>
	<p>Toxic Fumes. The engine exhaust from this product contains chemicals known to cause cancer and birth defects and other reproductive harm.</p> <p>Risk of Asphyxiation. This engine emits carbon monoxide, an odorless, colorless poison gas. Breathing carbon monoxide can cause nausea, fainting or death. Use only in a well-ventilated area.</p>
	<p>Clearance. Keep all objects including others at least 10 feet (3m) from this machine. Only one person should operate the log splitter and load the logs</p>
	<p>Never operate on an incline. Make sure the splitter is on a level surface. Block tires and ensure support leg is secure to prevent unintended movement of the log splitter during operation.</p>

Operation Symbols

Some of the following symbols may be used on this product. Please study them and learn their meaning. Proper interpretation of these symbols will allow you to more safely operate the product.

SYMBOL		MEANING
		ON
		STOP or OFF
		Fuel/Gasoline Valve ON/OFF

Quickstart Label Symbols

Some of the following symbols may be used on this product. Please study them and learn their meaning. Proper interpretation of these symbols will allow you to more safely operate the product.

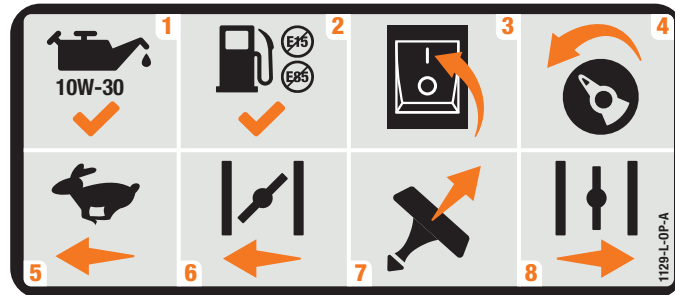

Starting the Engine

⚠ DANGER

Move log splitter outside and far away from windows, doors and intake ventilation covers.

- 1. Check oil level.**
Recommended oil is 10W-30.
- 2. Check gasoline level.**
When adding gasoline, use a minimum octane rating of 85 and an ethanol content of 10% or less by volume.
3. Press engine switch to the **“ON”** position.
4. Turn the fuel valve to **“ON”** position.
5. Move the throttle lever to the **“FAST”** position.
6. Move choke lever to **“CHOKE”** position.
7. Pull the recoil cord.
8. Move the choke lever to **“RUN”** position.

CONTROLS AND FEATURES

Read this operator's manual before operating your log splitter. Familiarize yourself with the location and function of the controls and features. Save this manual for future reference.

Log Splitter

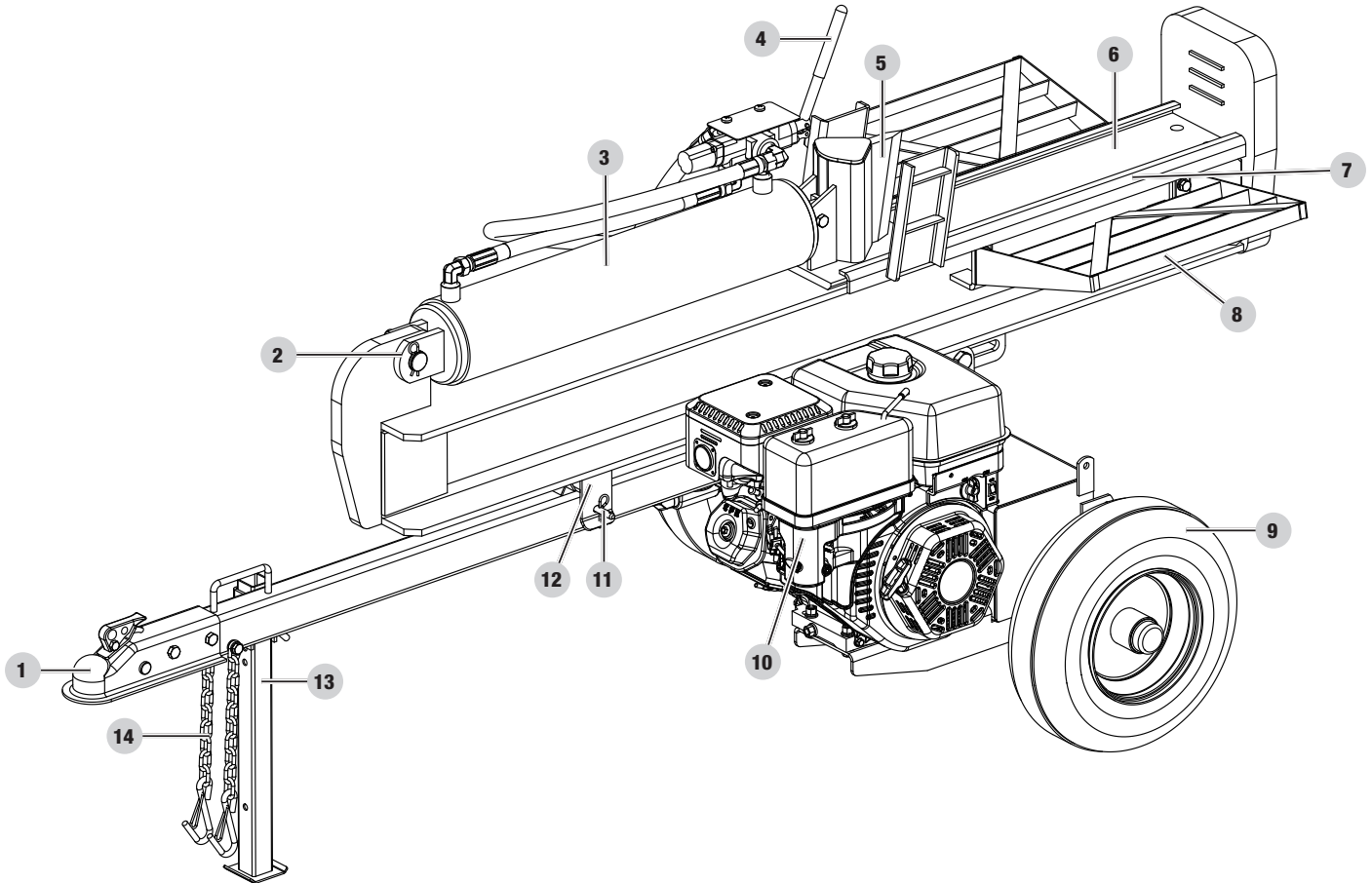

1. **2 in. (5.1 cm) Ball Coupler** – For towing the log splitter behind your vehicle.
2. **Mounting Plates** – Holds hydraulic cylinder in place.
3. **Hydraulic Cylinder** – Converts hydraulic pressure into linear force.
4. **Control Valve Handle** – Controls the movement of the cutting wedge.
5. **Wedge**
6. **Splitting Beam**
7. **Log Cradle** – Prevents log from rolling off the beam.
8. **Log Catchers**
9. **Tires** – Maximum travel speed is 45 MPH (72 KM/H).
10. **Engine** – 338cc, OHV.
11. **Beam Lock Pin** – Secures in either horizontal or vertical position.
12. **Beam Bracket** – Holds splitting beam in place.
13. **Support Leg** – Supports log splitter while operating. Raise leg for towing.
14. **Safety Chains** – For use while towing.

Engine

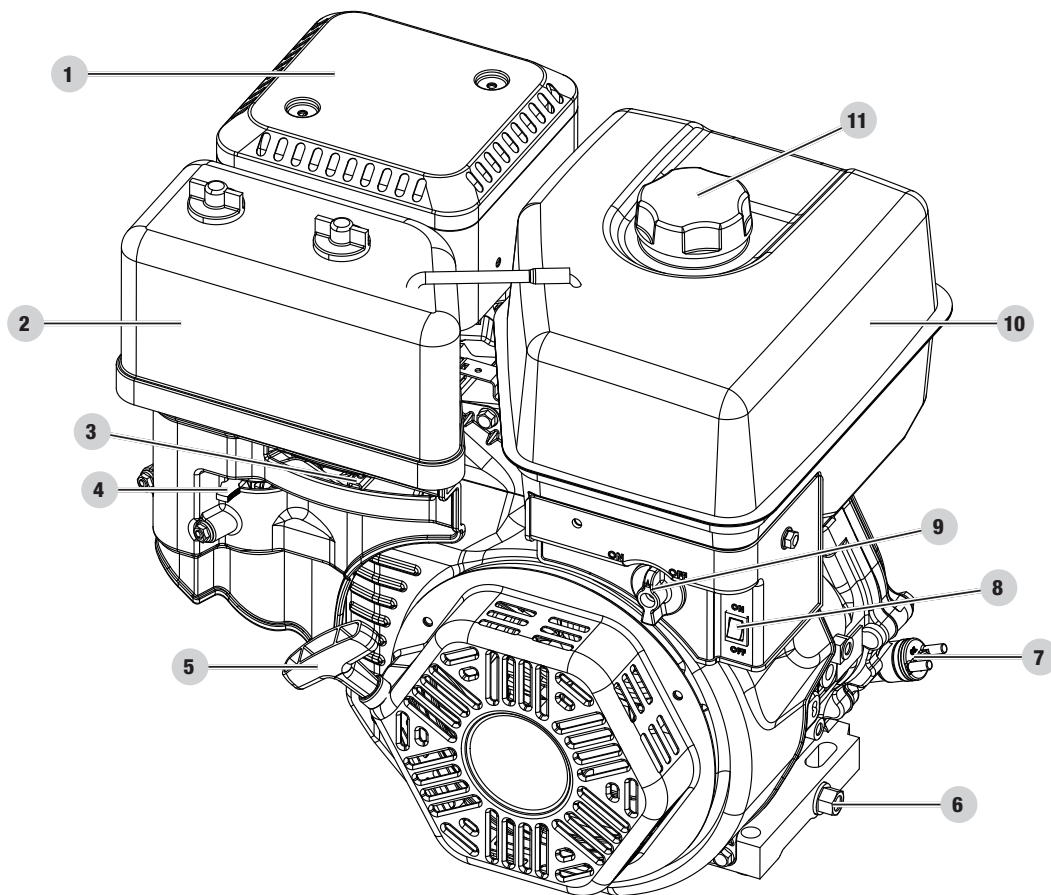

1. **Muffler**
2. **Air Filter** – Protects the engine by filtering dust and debris from the intake air.
3. **Throttle** – Used to control the engine speed.
4. **Choke** – Used to start the engine.
5. **Recoil Starter** – Used to manually start the engine.
6. **Oil Drain Bolt** – Used to drain the oil from the engine.
7. **Oil Fill Cap/Dipstick** – Used to check and fill oil level.
8. **Engine Switch** – Used to put in START mode or STOP the engine.
9. **Fuel Valve** – Used to turn fuel supply on and off to engine.
10. **Gasoline Tank** – 1.6 gal. (6.2 L)
11. **Fuel Cap** – Remove to add fuel.

Parts Included

Part	Part Qty.	Hardware Needed	Hardware Qty.	Tool Needed
Wheels	2	Castle Nut	2	1× 30mm open-end wrench
		Cotter Pin Ø4 × 32	2	Needle nose pliers
		Axle Cap	2	Mallet
Tow Bar	1	Bolt M12 × 85	2	1× 18mm wrench or socket
		Nut M12	4	1× 19mm wrench or socket
		Flat Washer Ø12	4	
Support Leg	1	Pin	1	
		R-Pin	1	
Beam	1	Bolt M18 × 145	1	1× 26mm wrench or socket
		Lock Nut M18	1	1× 27mm wrench or socket
		Lock Pin	1	Use for either Vertical or Horizontal
		R-Pin	1	
Cylinder	1	Cylinder Pin	1	
		R-Pin	2	
Wedge	1	Bolt M12 × 75(12.9)	1	1× 18mm wrench or socket
		Nut M12	1	1× 19mm wrench or socket
		Flat Washer Ø12	1	
External Hydraulic Oil Filter	1			Pipe wrench
Engine	1	Bolt M10 × 45	4	1× 16mm wrench
		Lock Nut M10	4	1× 17mm wrench
		Flat Washer Ø10	4	
High Pressure Hose	1			1× 27mm open-end wrench
Oil Return Hose	1			1× 27mm open-end wrench
Suction Hose	1	C-clamp	2	1× flat head screw driver or 8mm socket
Log Catchers	2	Bolt M10 × 15	8	1× 16mm wrench or socket
		Lock Washer Ø10	8	
		Flat Washer Ø10	8	

Parts Not Included

- Engine Oil (10W-30) 37.2 fl. oz (1.1 L)
- Hydraulic Oil (ISO 32) 6.8 gal. (25.7 L)

ASSEMBLY

Your log splitter requires some assembly.

If you have any questions regarding the assembly of your log splitter, call our help line at 1-877-338-0999. Please have your serial number and model number available.

Open Shipping Crate

1. Set the shipping crate on a solid, flat surface
2. Carefully cut the shipping bands and remove lid of shipping crate.
3. Locate all hardware before beginning assembly.

1) Install the Hydraulic Oil Filter

1. Install the oil filter base onto the hydraulic oil tank. The barb fitting should be oriented vertically and once installed the oil filter should be oriented so that it does not extend below the hydraulic oil tank.

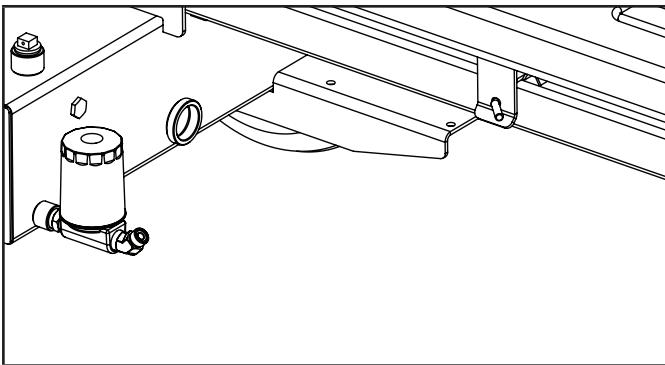

2) Install the Wheels

1. Remove the two plastic shipping caps from the wheel hubs.
2. Slide the wheel (27) onto the axle. Be sure the tire valve stem is facing out.
3. Thread the castle nut (25) on the axle and tighten by hand. Use a wrench to tighten another ¼ turn.
4. Spin the wheel (27) to distribute the bearing grease.
5. Loosen the castle nut (25) and re-tighten by hand.
6. Install the cotter pin (29) through the axle and castle nut. (25)
7. Check to be sure the wheel (27) spins freely.
8. Install the axle cap (24) using a soft face mallet or hammer and wood block.
9. Repeat for the other wheel.

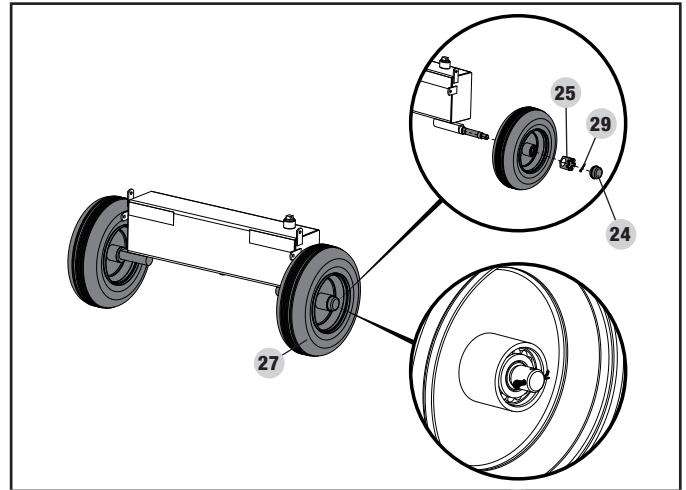

NOTICE

Keep dirt and debris away from the wheel bearings during assembly.

CAUTION

Over-tightening the castle nut will cause the bearings to run hot and fail prematurely.

3) Install the Tow Bar

1. Attach the tow bar (57) to the bracket on top of the hydraulic oil tank (30) with two M12x85 bolts (35), M12 washers (3) and M12 lock nuts (2).

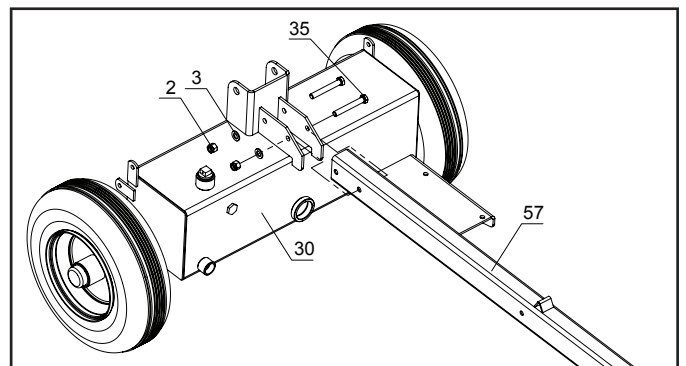

4) Install the Support Leg

1. Insert the support leg (67) into the leg holder on the tow bar and secure with pin (66) and R-pin (38).

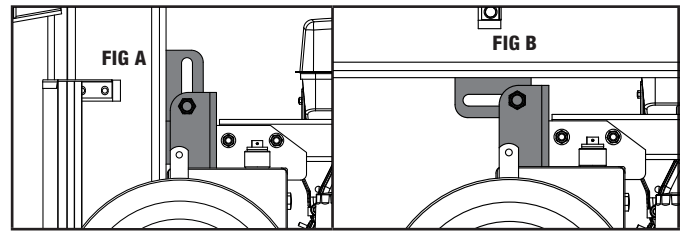
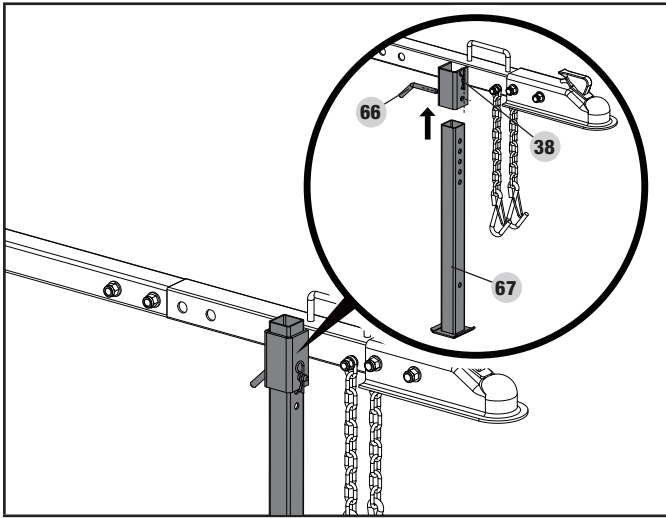

4. Pivot the beam to the horizontal position and secure it with the lock pin (37) and R-clip (38) through the tow bar.

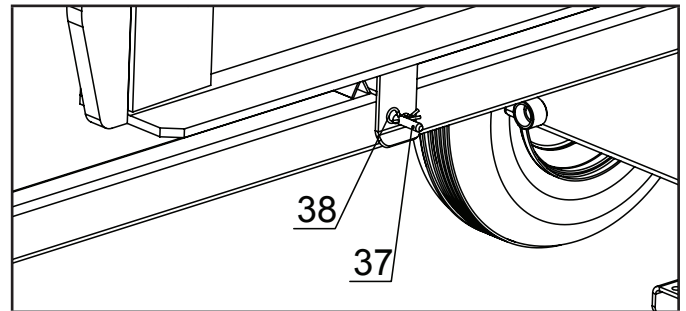

5) Install the Beam

1. Stand the beam (1) vertical on the foot plate.
2. Roll the tank into position so the pivot holes of the tank and beam are aligned.
3. Insert the bolt (36) and secure it with the lock nut (34).

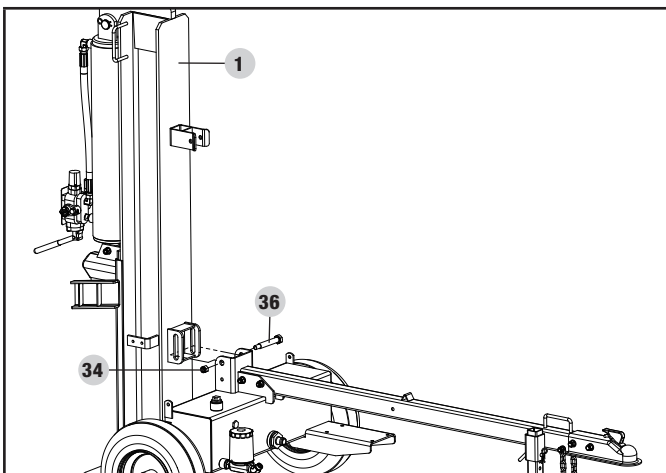

⚠ WARNING

The beam is extremely heavy and should only be handled with 2 or more people. DO NOT try and lift or handle the beam without assistance.

6) Install the Cylinder and Wedge

1. Slide the wedge (4) under the beam rails. Push it toward the foot plate to make room for the cylinder (16).
2. Position the cylinder clevis between the mounting plates at the end of the beam.
3. Align the holes in the cylinder clevis to the holes on the mounting channels on the beam.
4. Slide the cylinder pin (18) through the mounting channel and cylinder clevis holes and secure with the two R-clips (17).
5. Align the holes in the cylinder rod end with the holes in the wedge.
6. Secure the cylinder rod end to the wedge with the bolt (5), washer (3) and lock nut (2). Tighten, but DO NOT over tighten.

🗨 NOTICE

The bolt (36) should slide with little resistance in the slotted hole

- When in the vertical position, the bolt should be at the rear/bottom of the slotted hole (see Fig. A)
- When in the horizontal position, the bolt should be at the front/top of the slotted hole (see Fig. B)

If the bolt does not slide to the correct position when the beam is transitioned, loosen the nut in half turn increments until it does.

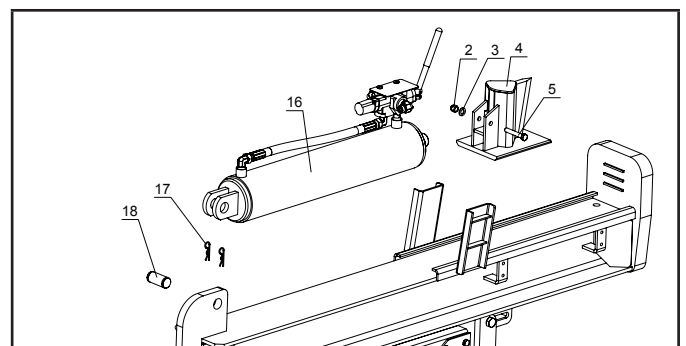

NOTICE

The cylinder rod may need to be rotated slightly in order to properly align the wedge. Insert a screwdriver into the bolt hole in the cylinder rod and slowly rotate as needed.

7) Install the Engine and Hoses**NOTICE**

Some hoses may be preassembled by the factory, check your hoses per below instructions to ensure proper assembly.

Oil Inlet (High Pressure) and Oil Return Hoses

- These hoses are black and have swivel nuts on both ends.
- The Oil Inlet Hose (19) sends hydraulic oil from the pump to the control valve/cylinder.
- The Oil Return Hose (64) returns hydraulic oil from the control valve/cylinder to the tank.
- Hose connections do NOT require thread seal tape. The O-ring seals against the face of the fittings on the pump and hose.

Suction Hose

- This is the clear hose that connects the hydraulic tank to the pump inlet.
- Secure both ends of hose with hose clamps.

Suction Hose

- Using the provided d32 hose clamps (40), connect one end of the clear oil hose (60) to the hydraulic oil tank (A) just beneath the engine and the other end to the pump inlet on the bottom of the pump (B). Securely tighten the clamps on both ends of the clear hydraulic hose with either a flat head screw driver or 8mm socket (Torque to 2.9-4.4 ft lbs.).

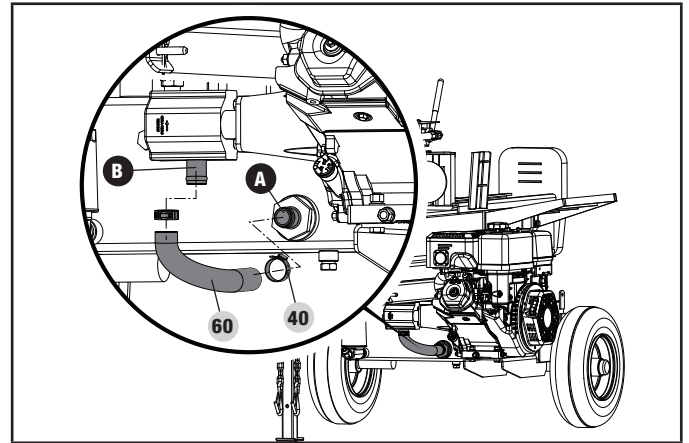
**Oil Return (Low Pressure) Hose**

- Using the provided inlet connector (7), add 2-3 wraps of new Teflon® tape to prevent oil leaks. Securely tighten the fitting with 27mm wrench (Torque to 51.7-66.4 ft lbs.). Make sure the fitting when fully tightening faces upward as shown.

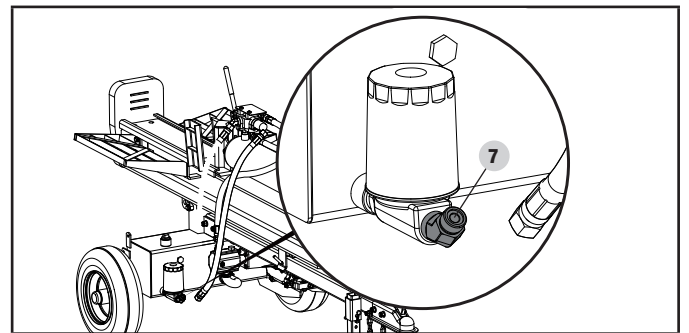

- Place an o-ring into tank inlet connector installed in the previous step. Make sure the o-ring is properly placed in the inner groove. Connect the end of hose (64) to the tank inlet connector. Securely tighten the end with a 27mm wrench (Torque to 44 - 52 ft lbs.).

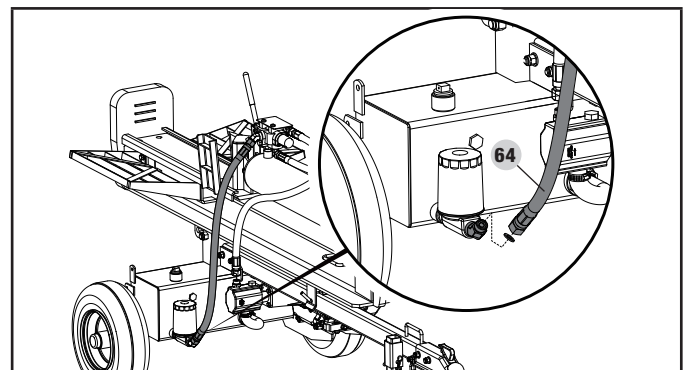
**Engine**

- Align the 4 holes on the base of the engine with the 4 holes on the engine mount.
- Thread an M8×45 bolt (47) through a washer (22), and (68) M10 lock nut.
- Thread bolt and washers through a hole on the bottom of the engine mount into the engine and add the lock nut. (Torque to 44 - 52 ft lbs.).
- Repeat steps 1-3 for the rest of the engine mounting hardware.

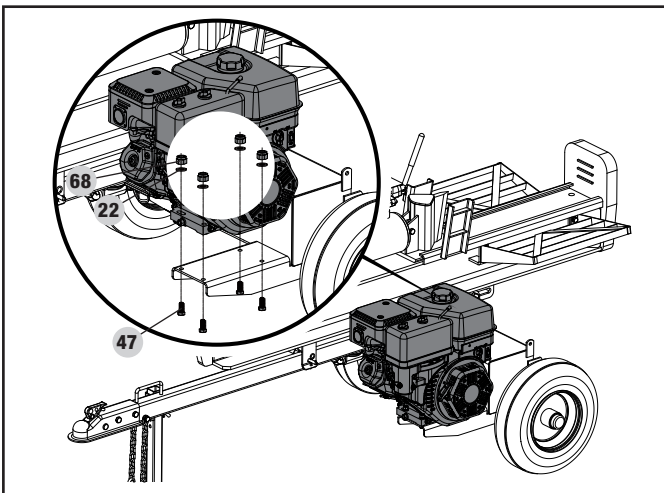

Oil Inlet (High Pressure) Hose

- Place an o-ring into pump outlet fitting. Make sure the o-ring is properly placed in the inner groove. Connect the other end of the high pressure hose (19) to the pump outlet. Securely tighten the end of hydraulic hose with a 27mm wrench (Torque to 44 - 52 ft lbs.).

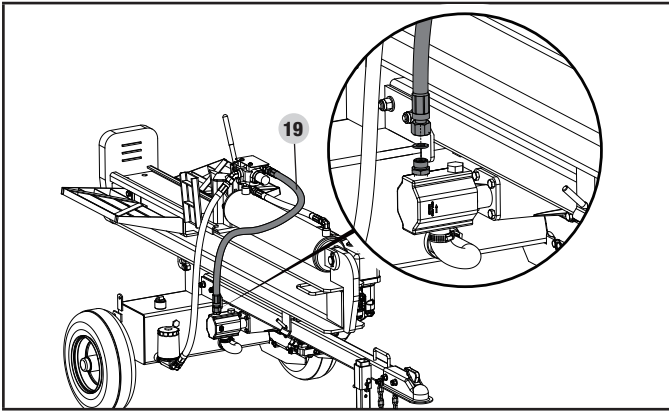

8) Install the Log Catchers

- Attach log catcher (23) to side of beam with four M10×15 bolts (20), M10 lock washers (21), and M10 washers (22).
- Repeat step 1 for the other side.

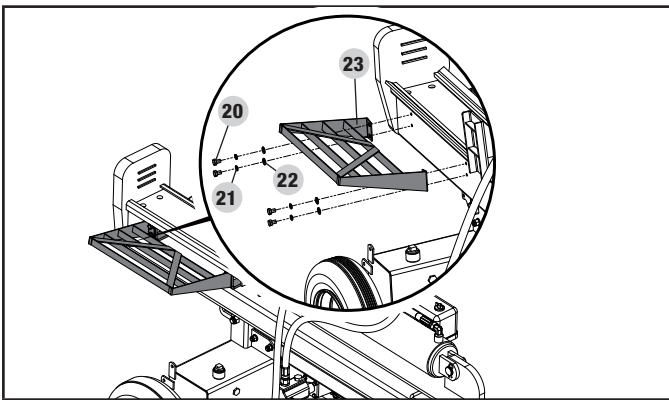

Add Engine Oil

CAUTION

DO NOT attempt to crank or start the engine before it has been properly filled with the recommended type and amount of oil. Damage to the engine as a result of failure to follow these instructions will void your warranty.

NOTICE

The recommended oil type is **10W-30 automotive oil**.

- Place the log splitter on a flat, level surface.
- Remove oil fill cap/dipstick to add oil.
- Using a funnel, add up to 37.2 fl. oz. (1.1 L) of oil and replace oil fill cap/dipstick. **DO NOT OVERFILL.**
- Check engine oil level daily and add as needed.

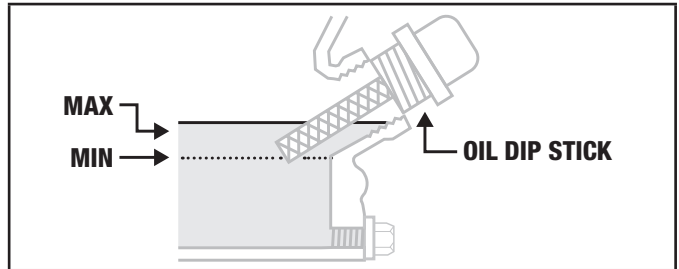

NOTICE

Once oil has been added, a visual check should show oil about 1-2 threads from running out of the fill hole.

If using the dipstick to check oil level, DO NOT screw in the dipstick while checking.

NOTICE

Check oil often during the break-in period. Refer to the Maintenance section for recommended service intervals.

CAUTION

The engine is equipped with a low oil shut-off and will stop when the oil level in the crankcase falls below the threshold level.

NOTICE

We consider the first 5 hours of run time to be the break-in period for the engine. During the break in period we recommend using standard automotive non-synthetic blended oils. After the break in period synthetic lubricant can be used but is not required. Adjusting throttle setting will increase/decrease engine speed helping to seat piston rings. Avoid bogging or lugging the engine down and avoid prolonged running at constant RPM. After the 5 hour break-in period, change the oil. Using synthetic lubricants does not increase the recommended oil change interval.

NOTICE

Synthetic oil may be used after the 5 hour initial break-in period. Using synthetic oil does not increase the recommended oil change interval. Full synthetic 5W-30 oil will aid in starting in cold ambient < 41° F (5° C).

Recommended Engine Oil Type									
		10W-30							
	5W-30					10W-40			
	5W-30 Synthetic								
°F	-20	0	20	40	60	80	100	120	
°C	-28.9	-17.8	-6.7	4.4	15.6	26.7	37.8	48.9	
Ambient temperature									

NOTICE

Weather will affect engine oil and engine performance. Change the type of engine oil used based on weather conditions to suit the engine needs.

Add Fuel

1. Use clean, fresh, regular unleaded gasoline with a minimum octane rating of 85 and an ethanol content of less than 10% by volume. (E10, E85, E85)
2. DO NOT mix oil with gasoline.
3. Remove the gasoline cap.
4. Slowly add gasoline to the tank. DO NOT OVERFILL. Gasoline can expand after filling. A minimum of ¼ in. (6.4 mm) of space left in the tank is required for gasoline expansion, although more than ¼ in. (6.4 mm) is recommended. Gasoline can be forced out of the tank as a result of expansion if overfilled, and can affect the stable running condition of the log splitter.
5. Screw on the gasoline cap and wipe away any spilled fuel.

CAUTION

Use regular unleaded gasoline with a minimum octane rating of 85 and an ethanol content of less than 10% by volume.

DO NOT mix oil and gasoline.

Fill tank to approximately ¼ in. (6.4 mm) below the top of the tank to allow for gasoline expansion.

DO NOT pump gasoline directly into the log splitter at the pump. Use an approved container to transfer the gasoline to the log splitter.

DO NOT fill tank indoors.

DO NOT fill tank when the engine is running or hot.

DO NOT overfill the tank.

DO NOT light cigarettes or smoke when filling the tank.

WARNING

Pouring gasoline too fast through the fuel screen may result in blow back of gasoline at the operator while filling.

NOTICE

Our engines work well with 10% or less ethanol blend gasoline. When using ethanol-gasoline blends there are some issues worth noting:

- Ethanol-gasoline blends can absorb more water than gasoline alone.
- These blends can eventually separate, leaving water or a watery goo in the tank, fuel valve and carburetor.
- With gravity-fed supplies, the compromised gasoline can be drawn into the carburetor and cause damage to the engine and/or potential hazards.
- There are only a few suppliers of fuel stabilizer that are formulated to work with ethanol-gasoline blends.
- Any damages or hazards caused by using improper gasoline, improperly stored gasoline, and/or improperly formulated stabilizers, are not covered by manufacturer's warranty.

It is advisable to always shut off the gasoline supply, run the engine to starvation and drain the tank when the equipment is not in use for more than 30 days.

Add Hydraulic Oil

1. Make sure the log splitter is on a flat, level surface.
2. Remove the oil plug from the oil tank. (A)
3. Add 5 gal. (18.9 L) of hydraulic oil - see specification section for types of acceptable oil.
4. Check the hydraulic oil level using the oil sight glass. Oil level should visibly fill the glass sight. (B)

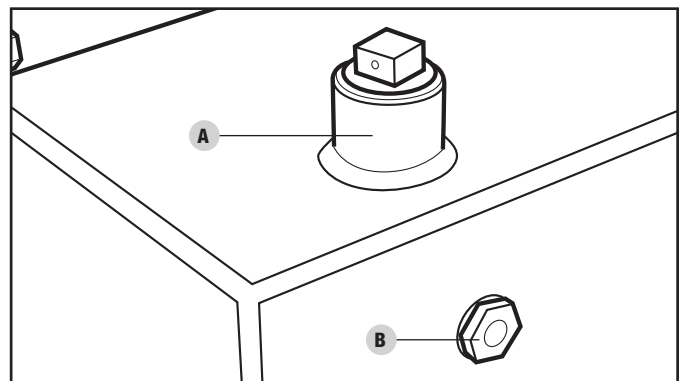

⚠ WARNING

DO NOT remove the hydraulic oil fill cap when the engine is running or hot. Hot oil can escape causing severe burns. Always allow the log splitter to cool completely before removing the hydraulic oil cap.

High fluid pressure and temperatures are created in the hydraulic log splitters. Hydraulic fluid will escape through a pin-size hole opening and can puncture skin and cause severe blood poisoning.

Inspect hydraulic system regularly for possible leaks. Never check for leaks with your hand while the system is pressurized. Seek medical attention immediately if injured by escaping fluid.

5. Replace and tighten the oil plug and orient the vent hole away from the operator zone.
6. Start Engine. Extend and retract the wedge to purge air from the hydraulic system. When the wedge motion is smooth, the system is properly purged.
7. Check the hydraulic oil tank sight glass. Add 1.8 gal. (6.8 L) of hydraulic oil to bring the level back up to the sight glass.
8. Check oil level daily and add as needed.

OPERATION**Before Each Use Inspect the Log Splitter**

1. Check the hydraulic oil level and visually inspect all hoses, attachments and cylinder for loose fittings, leaks, cracks, fraying or other damage.
2. DO NOT operate the log splitter if there is any indication of damage.
3. Inspect the engine and make sure the oil level is correct before operating. If the engine is equipped with a spark arrestor, clean and inspect it regularly (follow spark arrestor maintenance schedule).
4. The tires need to be fully inflated and in good repair. Reference the tire sidewall for recommended tire pressure.

⚠ WARNING

DO NOT over inflate tires. Serious injury can result if tires explode.

DO NOT tow the log splitter if the tires are worn or will not hold air.

DO NOT exceed the maximum 45 MPH (72 KM/H) towing speed.

Changing Beam from Horizontal to Vertical Orientation

When logs are too heavy to lift, log splitter beam can be moved from horizontal to vertical orientation.

To change from horizontal to vertical orientation:

1. Remove "R" (38) clip and pin (37) that locks the beam to the tow bar.

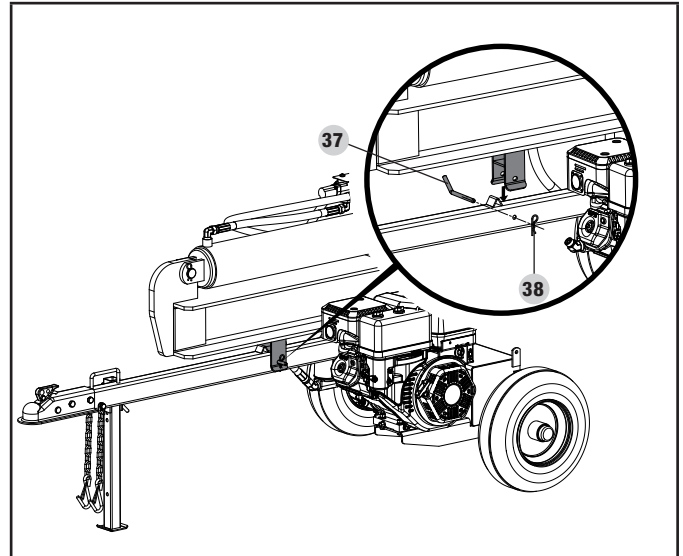

2. Standing alongside the hydraulic ram, (opposite side from the engine) firmly grasp the handle on the beam and lift upward while pushing the beam back until upright. (Caution, beam is heavy.)

Towing Log Splitter Safety

1. Always check local and state regulations regarding the requirements for towing, licensing and lights.
2. Before towing make sure the log splitter is correctly and securely attached to the vehicle and the safety chains attached with enough slack to allow for turning.
3. Never exceed the max. travel speed of 45 MPH (72 km/h). Towing the log splitter at speeds greater than 45 MPH (72 km/h) could result in serious injury or death. Always adjust your towing speed according to the terrain and conditions.
4. Always disconnect the log splitter from the towing vehicle before operating.

Log Splitter Location

This log splitter must have at least seven feet of clearance from combustible material. Leave at least three feet of clearance on all sides of the log splitter to allow for adequate cooling, maintenance and servicing. DO NOT place the log splitter near vents or intakes where engine exhaust fumes could be drawn into occupied or confined spaces. **ONLY operate the log splitter outdoors.**

The log splitter needs to be on a dry level surface with good footing. DO NOT work on mud, ice, tall grass, brush or snow.

Only operate log splitter from work zone shown below.

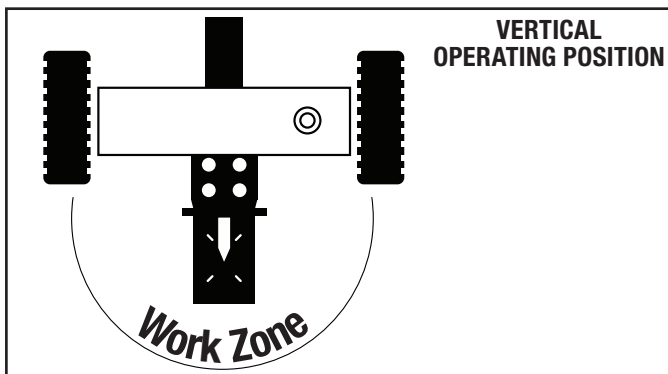
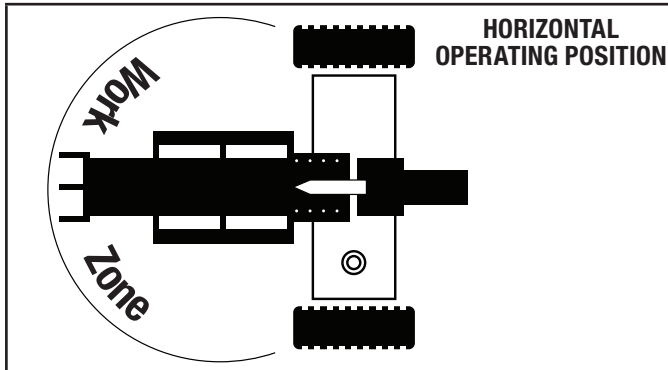

⚠ WARNING

ALWAYS use the log splitter for its intended use. The log splitter should only be used to split wood logs, length wise with the grain.

NEVER modify, alter or change the log splitter in anyway. Modifications will void the warranty.

NEVER attach a rope, cable or other device to the control lever on the log splitter.

DO NOT modify or change the engine and operating speeds or pressure settings. These changes can cause safety issues.

ONLY operate the log splitter in daylight.

NEVER operate, or let anyone else operate, the log splitter while under the influence of alcohol, drugs, or medication.

NEVER leave the log splitter unattended while the engine is running.

DO NOT change the splitting position with the engine running. Contact with the muffler can cause serious burns.

ALWAYS make sure the beam is in the locked position.

DO NOT let the beam drop as it could crush fingers or cause damage to the log splitter.

Starting the Engine

1. Make certain the log splitter is on a flat, level surface.
2. Flip engine switch to "ON" position (Item A).
3. Rotate the fuel valve to the "ON" position (Item B).
4. Move the throttle lever (Item C) to the "FAST" position.
5. Move the choke lever (Item D) to the "CHOKE" position.
6. Pull the starter cord slowly until resistance is felt and then pull rapidly. SEE FOLLOWING NOTE.
7. As engine warms up, move the choke lever (Item D) to "RUN."

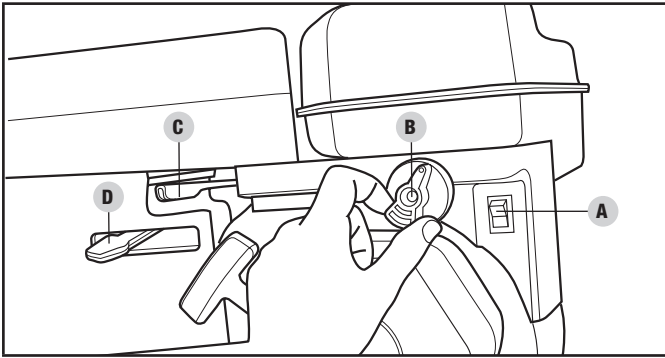

NOTICE

Keep choke lever in “CHOKE” position for 2 pulls of the recoil starter. After second pull, move choke lever to the “RUN” position for up to the next 3 pulls of the recoil starter. Too much choke leads to spark plug fouling/engine flooding due to the lack of incoming air. This will cause the engine not to start.

NOTICE

If the engine starts but does not run make certain that the log splitter is on a flat, level surface. The engine is equipped with a low oil sensor that will prevent the engine from running when the oil level falls below a critical threshold.

Stopping the Engine

1. Turn the fuel valve to the “OFF” position.
2. Let the engine run until fuel starvation has stopped the engine. This usually takes a few minutes.
3. Turn the engine switch to the “OFF” position.

Important: Always ensure that the fuel valve and the engine switch are in the “OFF” position when the engine is not in use.

NOTICE

If the engine will not be used for a period of two (2) weeks or longer, please see the Storage section for proper engine and fuel storage.

Log Splitter Operation

1. ALWAYS wear ear and eye protection, protective clothing and safety gear.

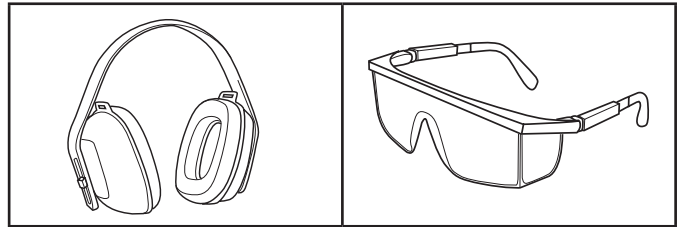

2. Block tires and ensure support leg is secure to prevent unintended movement of the log splitter during operation.
3. Set log splitter in either the horizontal or vertical position.

NOTICE

HORIZONTAL position is used for lighter logs that can easily be loaded onto the beam.

VERTICAL position is used for light logs as well as heavy logs that are difficult to load onto the beam.

Back injury can result from lifting logs onto the log splitter if proper lifting techniques are not used.

4. Load a log onto the beam against the end plate (MAX LOG LENGTH – 24 in. [61 cm]).
5. Make sure all limbs are clear of crush zones.
6. Push the control valve handle forward (towards the end plate) to split the log.
7. Push the auto control valve handle backward to return the wedge to its original position.
8. Clear the split wood from the work zone.

NOTICE

It is normal for the hydraulic fluid to appear foamy/frothy during operation.

NOTICE

If a log gets stuck, embedded or will not split completely, push the control handle in the reverse direction and allow the splitter to strip the log from the wedge.

ALWAYS keep hands clear of the log and wedge while it is retracting.

NOTICE

The cylinder stroke is designed so the wedge stops approximately 1.5 in. (3.8 cm) from the end plate.

Operation at High Altitude

The density of air at high altitude is lower than at sea level. Engine power is reduced as the air mass and air-fuel ratio decrease. Engine power and log splitter output will be reduced approximately 3½% for every 1000 ft. of elevation above sea level. This is a natural trend and cannot be changed by adjusting the engine. At high altitudes increased exhaust emissions can also result due to the increased enrichment of the air fuel ratio. Other high altitude issues can include hard starting, increased fuel consumption and spark plug fouling.

To alleviate high altitude issues other than the natural power loss, CPE can provide a high altitude carburetor main jet. The alternative main jet and installation instructions can be obtained by contacting our Technical Support Team. Installation instructions are also available in the Technical Bulletin area of the CPE website.

The part number and recommended minimum altitude for the application of the high altitude carburetor main jet is listed in the table below.

In order to select the correct high altitude main jet it is necessary to identify the carburetor model. For this purpose, a code is stamped on the side of the carburetor. Select the correct high altitude jet part number corresponding to the carburetor code found on your particular carburetor.

Carb. Code	High Alt. Jet Part Number	Min. Altitude
P23-1-Z	46.131017.01.01.Z	4500 ft. (1372 m)
P23-1-Y	46.131017.01.01.Y	
P23-1-H	46.131017.01.01.H	

⚠ WARNING

Operation using the alternative main jet at elevations lower than the recommended minimum altitude can damage the engine. For operation at lower elevations, the originally supplied standard main jet must be used. Operating the engine with the wrong engine configuration at a given altitude may increase its emissions and decrease fuel efficiency and performance.

MAINTENANCE

Make certain that the log splitter is kept clean and stored properly. Only operate the unit on a flat, level surface in a clean, dry operating environment. DO NOT expose the unit to extreme conditions, excessive dust, dirt, moisture or corrosive vapors. Inspect all air vents and cooling slots to ensure that they are clean and unobstructed.

Clean spark arrester every 100 hours.

Check and tighten all bolts and nuts before operating the log splitter.

⚠ WARNING

Never operate a damaged or defective log splitter.

⚠ WARNING

Improper maintenance will void your warranty.

🗨 NOTICE

Maintenance, replacement, or repair of emission control devices and systems may be performed by any non-road engine repair establishment or individual.

The owner/operator is responsible for all periodic maintenance.

Complete all scheduled maintenance in a timely manner.

Correct any issue before operating the log splitter.

For service or parts assistance, contact our Technical Support Team at 1-877-338-0999.

Cleaning the Log splitter

⚠ CAUTION

DO NOT spray engine with water.

Water can contaminate the fuel system and can enter the engine through the cooling slots and damage the engine.

Clear the debris from the beam, wedge and endplate.

Use a damp cloth to clean exterior surfaces of the engine and log splitter.

Use a soft bristle brush to remove excess dirt and oil.

Use an air compressor (25 PSI) to clear dirt and small debris.

Wipe all metal parts with an oily rag to help prevent rust and corrosion.

Changing the Engine Oil

Change oil when the engine is warm. Refer to the oil specification to select the proper grade for your operating environment.

1. Remove the oil drain bolt with a 15 mm socket (not included) and extension.

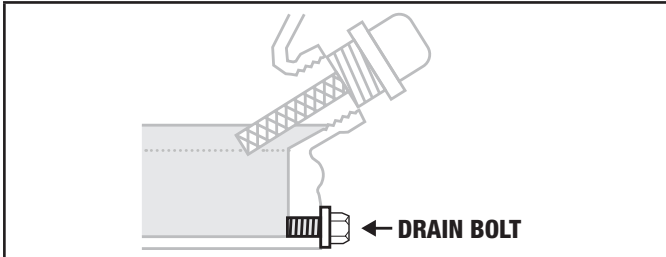

2. Allow the oil to drain completely into an appropriate container.
3. Replace the oil drain plug.
4. Remove the oil fill cap/dipstick to add oil.
5. Using a funnel, add up to 37.2 fl. oz. (1.1 L) of oil (not included) and replace oil fill cap/dipstick. **DO NOT OVERFILL.**
6. Dispose of used oil at an approved waste management facility.

NOTICE

Once oil has been added, a visual check should show oil about 1-2 threads from running out of the fill hole. If using the dipstick to check oil level, **DO NOT** screw in the dipstick while checking.

Cleaning and Adjusting the Spark Plug(s)

1. Remove the spark plug cable from the spark plug.
2. Use a spark plug socket (not included) to remove the plug.
3. Inspect the electrode on the plug. It must be clean and not worn to produce the spark required for ignition.
4. Make certain the spark plug gap is 0.7 - 0.8 mm (0.028 - 0.031 in.).

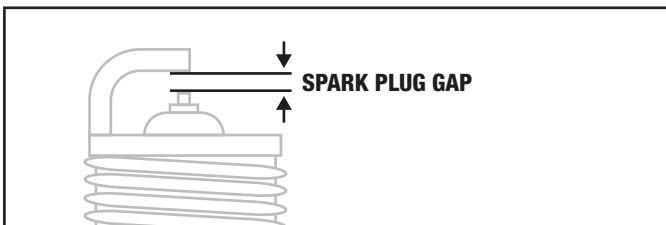

5. Refer to the spark plug section on the Specifications page when replacing the plug.
6. Carefully thread the plug into the engine.
7. Use a spark plug socket (not included) to firmly install the plug.

8. Attach the spark plug wire to the plug.

Cleaning the Air Filter

1. Using your fingers, unscrew the thumb screws of the top holes of the air filter cover.
2. Remove the plastic outer casing.
3. Remove the foam element.
4. Wash in liquid detergent and water. Squeeze thoroughly dry in a clean cloth.
5. Saturate in clean engine oil.
6. Squeeze in a clean, absorbent cloth to remove all excess oil.
7. Place the filter in the assembly.
8. Reattach the air filter cover and using your fingers, insert the thumb screws into the top and bottom holes of the air filter cover. Screw until tight. Be sure not to over tighten.

Changing the Hydraulic Oil and Oil Filter

NOTICE

Install a new hydraulic oil filter each time the hydraulic oil is changed.

1. Begin with the cylinder retracted and the engine "OFF."
2. Turn the fuel valve "OFF."
3. Release any stored pressure by moving the valve lever forward and backward several times.
4. Place a container under the hydraulic tank. Make sure it is large enough to hold the contents of the tank.
5. To drain the oil, unscrew and remove the tank drain plug on the bottom of the hydraulic tank.
 - 5a. Unscrew and remove the hydraulic oil filter.
 - 5b. Drain any oil in the filter into the container.
6. Allow oil to completely drain from the tank into the container.
7. Install a new hydraulic oil filter. (A)
 - 7a. Turn the filter counter-clockwise to remove it. A strap wrench may be used.
 - 7b. Lubricate the gasket of the new filter with a thin film of clean oil.
 - 7c. Screw the new filter on clockwise. Tighten 3/4 - 1 turn after the gasket makes contact.
8. Reinsert and screw in the tank drain plug. Tighten, but do not over tighten.

NOTICE

The drain plug is sealed with Teflon tape. Add 2-3 wraps of new Teflon tape as needed when replacing the drain plug to prevent oil leak

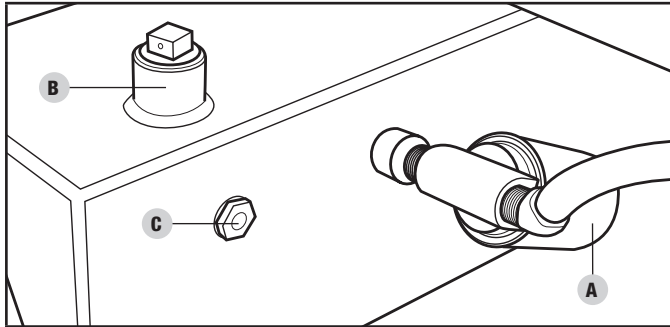

9. Unscrew and remove the tank fill plug, on top of the tank. Using a funnel add approximately 5 gal. (18.9 L) of hydraulic oil to the tank. Wipe up any spilled oil. (B)
10. Turn the fuel valve on, and start the engine. Purge the air from the system by extending and retracting the wedge several times until the motion is smooth.
11. Check the hydraulic oil level using the sight glass. Add 1.8 gal. (6.8 L) of hydraulic oil, so the oil level is visible in the sight glass. (C)
12. Dispose of used oil at approved recycling locations.

WARNING

Always shut off the engine, disconnect the spark plug, and relieve system pressure before cleaning, adjusting, or repairing the splitter. Relieve system pressure by moving split control lever back and forth several times.

NOTICE

Change the hydraulic oil filter after the first 50 hours of use. Then every 100 hours or seasonally.

NOTICE

Refer to Specifications for a list of compatible replacement filters or call Champion Power Equipment at 1-877-338-0999 to order a replacement OEM filter.

Maintenance Schedule

Follow the service intervals indicated in the following maintenance schedule.

Service your log splitter more frequently when operating in adverse conditions.

Contact our Technical Support Team at 1-877-338-0999 to locate the nearest CPE certified service dealer for your log splitter or engine maintenance needs.

EVERY 8 HOURS OR DAILY

- Check engine and hydraulic oil levels
- Clean around air intake and muffler

FIRST 5 HOURS

- Change oil

EVERY 50 HOURS OR EVERY SEASON

- Clean air filter
- Change oil if operating under heavy load or in hot environments

EVERY 100 HOURS OR EVERY SEASON

- Change oil
- Clean/adjust spark plug
- Check/adjust valve clearance*
- Clean spark arrestor
- Clean fuel tank and filter*
- Change hydraulic oil
- Change hydraulic oil filter

EVERY 250 HOURS

- Clean combustion chamber*

EVERY YEAR

- Inspect wheel bearings and repack bearing grease as needed.

EVERY 3 YEARS

- Replace fuel line*

*To be performed by knowledgeable, experienced owners or CPE certified service centers.

STORAGE

Refer to the Maintenance section for proper cleaning instructions.

Log Splitter Storage

1. The log splitter needs to be cool for at least 5 minutes before storing.
2. Clean the log splitter before storage according to the Maintenance section.
3. Retract the wedge to protect the rod from corrosion.
4. Wipe the beam and wedge with an oily rag to prevent rust and corrosion.

Engine Stored for Less than 30 Days

1. Allow the engine to cool completely before storage.
2. Clean engine according to the Maintenance section.
3. To extend the fuel storage life add a properly formulated fuel stabilizer to the tank.
4. Ensure the fuel valve is in the "OFF" position.

Engines Stored for Over 30 Days

1. Add a properly formulated fuel stabilizer to the tank.
2. Run the engine for a few minutes so the treated fuel cycles through the fuel system and carburetor.
3. Turn the fuel valve to the "OFF" position.
4. Let the engine run until fuel starvation has stopped the engine. This usually takes a few minutes.
5. The engine needs to cool completely before cleaning and storage.
6. Clean the engine according to the maintenance section.
7. Change the oil.
8. Remove the spark plug and pour about 14.8 mL (½ ounce) of oil into the cylinder. Using the Recoil, crank the engine slowly to distribute the oil and lubricate the cylinder.
9. Reattach the spark plug.

WARNING

Never store the log splitter inside next to appliances where there is a source of heat or open flame, spark or pilot light because they can ignite gasoline vapors.

DO NOT store a log splitter near fertilizer or any corrosive material. Even with an empty gas tank, gasoline vapors could ignite.

SPECIFICATIONS

Log Splitter Specifications

Ram Force	37 Ton
Cycle Time	16 seconds
Hydraulic Tank Capacity	5 gal (18.9 L)
Max Log Length	24 in. (61 cm)
Max Log Weight	100 lb. (45 kg)
Coupler Ball Size	2 in. (5.1 cm)
Tire Size	16 in. (40.6 cm)
Max towing speed	45 MPH (72 KPH)
Cylinder size	5 in. x 23 in. (12.7 cm x 58.4 cm)
Cylinder rod size	1.8 in. (4.5 cm)
Gear Pump	2-stage
Max pressure	3600 psi
Max flow capacity	13 GPM
Control Valve	Detent (auto-return)

Overall Dimensions

Gross Weight	657 lb. (298 kg)
Net Weight	566.6 lb. (257 kg)
Height	46.1 in. (117.2 cm)
Width	40.8 in. (103.7 cm)
Length	92.4 in. (234.7 cm)

Engine Specifications

Model	YF182F-001
Displacement	338 cc
Type	4-Stroke OHV
Start Type	Recoil

Oil Specifications

DO NOT OVERFILL.

Type See chart below
 Capacity 37.2 fl. oz. (1.1 L)

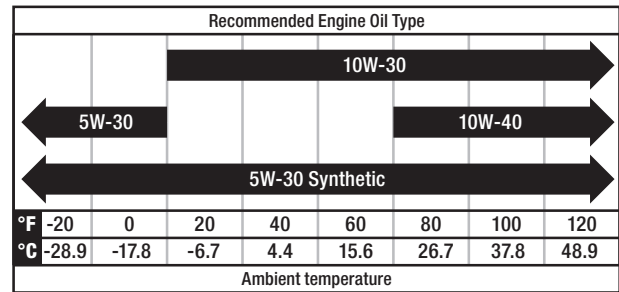

NOTICE

Weather will affect engine oil and engine performance. Change the type of engine oil used based on weather conditions to suit the engine needs.

Hydraulic Oil System

Type See Hydraulic oil chart
 Capacity 6.8 gal. (25.7 L)

NOTICE

Weather will affect hydraulic oil and log splitter performance. Change the type of hydraulic oil used based on weather conditions to suit the engine needs.

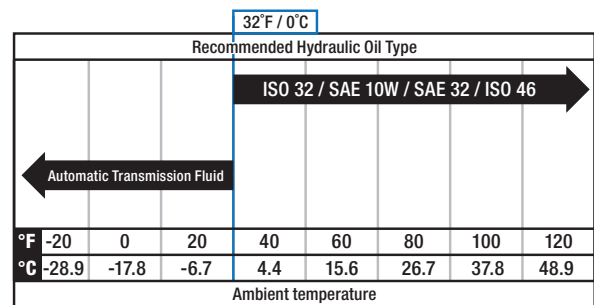

Fuel Specifications

Use regular unleaded gasoline with a minimum octane rating of 85 and an ethanol content of less than 10% by volume. DO NOT USE E15 or E85. DO NOT OVERFILL.

Gasoline Capacity 1.6 gal. (6.2 L)

Spark Plug Specifications

OEM Type NHSP F6RTC

Replacement Type NGK BPR6ES or equivalent

Gap 0.028-0.031 in. (0.7-0.8 mm)

Valve Specifications

Intake Clearance 0.005-0.007 in. (0.13-0.17 mm)

Exhaust Clearance 0.007-0.009 in. (0.18-0.22 mm)

NOTICE

A technical bulletin regarding valve adjustment procedures is available at www.championpowerequipment.com.

Important Message About Temperature

Your product is designed and rated for continuous operation at ambient temperatures up to 104°F (40°C). When your product is needed it may be operated at temperatures ranging from 2°F (-10°C) to 122°F (50°C) for short periods of time. If exposed to temperatures outside this range during storage, it should be brought back within this range before operation. In any event, the product must always be operated outdoors, in a well-ventilated area and away from doors, windows and vents.

Parts Diagram

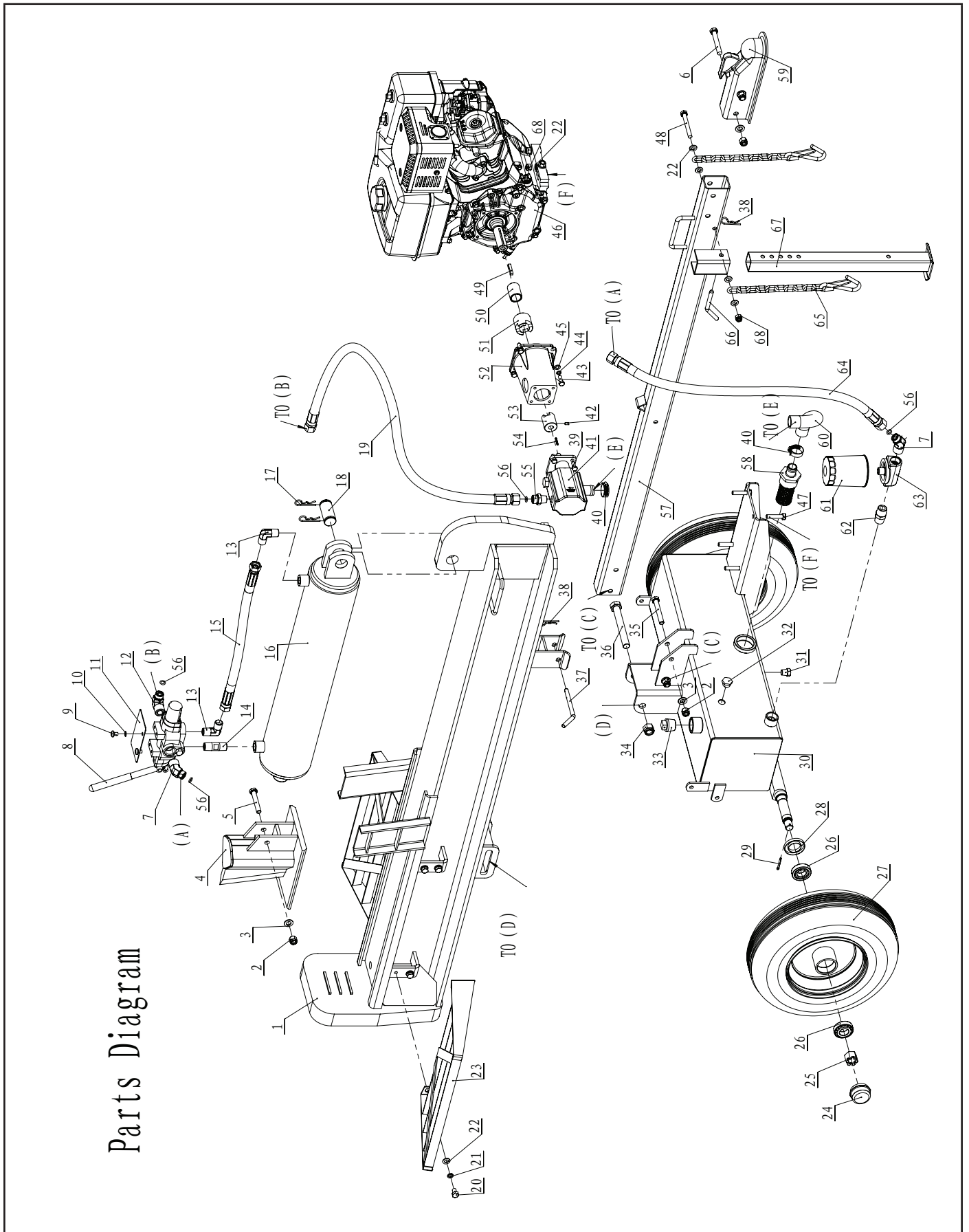

Parts List

#	Part Number	Description	Qty
1	PMJ37N-02-00	Beam	1
2	G889.1-2000-M12	Lock Nut M12	5
3	G95-2000-12	Washer Ø12	5
4	PMJ37N-04-00	Wedge Slide	1
5	G5782-2000-M12-75	Bolt 12x75 (12.9)	1
6	G5782-2000-M12-80	Bolt M12x80	2
7	PMJ20J-17	Filter Housing "OUT" Connection	2
8	PMJ22J-12	Control Valve	1
9	G818-2000-M8 - 12	Bolt M8x12	2
10	G859-1987-8	Washer Ø8	2
11	PMJ22J-19	Plate	1
12	PMJ20J-16	Filter Housing "IN" Connection	1
13	PMJ7-15	Right Angle Joiner	2
14	PMJ22M-22	Valve Joiner	1
15	PMJ37N-16	Hydraulic Hose(Valve-Cylinder)	1
16	PMJ37N-08-00-Y	Cylinder(Yellow)	1
17	GJY12-3	R Pin	2
18	PMJ37N-13	Wedge Pin	1
19	PMJ20J-18	Hydraulic Hose(Valve-Pump)	1
20	G5781-2000-M10-15	Bolt M10x15	8
21	G93-1987-10	Lock Washer Ø10	8
22	G95-2000-10	Washer Ø10	16
23	PMJ30F-01-Y	Log Catcher(Yellow)	2
24	PMJ22J-05-02	Axle Cap	2
25	G9459-1988-M20-1.5	Slotted Nut M20x1.5	2
26	L44634 LYC DS	Tapered Bearing	4
27	PMJ37N-05-03-Y	Wheel(Yellow)	2
28	PMJ22J-05-01	Cased Seal	2
29	G91-2000-4-32	Cotter Pin Ø4x32	2
30	PMJ37N-01-00	Oil Tank	1
31	PMJ22G-19	Oil Plug	1
32	G1160.2-89	Oil Scale	1
33	PMJ22G-18	Screw NPT 1 in.	1
34	G889.1-2000-M18	Lock Nut M18	1
35	G5782-2000-M12-85	Bolt M12x85	2
36	PMJ37N-14	Bolt M18x145	1
37	PMJ22J-15	Pin	1
38	PMJ22G-30	R Pin	2
39	G5783-2000-M8-20	Bolt M8x20	4
40	J8870-1999-d32	Clamp d32	2

#	Part Number	Description	Qty
41	PMJ35-10	Gear Pump	1
42	G77-2000-M6-10	Screw M6x10	1
43	ASME-B18.2.1-1996-516-24-1	Bolt 5/16 in.-24x1 in.	4
44	G93-1987-8	Lock Washer Ø8	4
45	G95-2000-8	Washer Ø8	4
46	44.104	Engine	1
47	G5780-2000-M10-45	Bolt M10x45	4
48	G5782-2000-M10-85	Bolt M10x85	1
49	PMJ30-32	Flat Key 6.3x35	1
50	PMJ30-29	Engine Bushing	1
51	PMJ30-28	Engine Connector	1
52	PMJ30-23	Gear Pump Stand	1
53	PMJ22G-26	Gear Pump Connector	1
54	G1096-1979-3.18-25.4	Flat Key 3.18x25.4	1
55	PMJ22G-21	Outlet Connector Of Pump	1
56	G3452.1-92-10-2.65	"O" Ring Ø10x2.65	4
57	PMJ37N-03A	Base Tube	1
58	PMJ22Q-20A	Internal Oil Filter	1
59	PMJ22G-40	2-in. Coupler	1
60	PMJ30-17	Oil Pipe	1
61	PMJ22G-52	Auto Filter	1
62	PMJ22Q-23	Through Joint	1
63	PMJ25M-20-00	Auto Filter Base	1
64	PMJ20J-15	Hydraulic Hose(Valve-Oil Tank)	1
65	PMJ25M-18-00	Safety Chain With Hook	2
66	PMJ22J-10	Pin	1
67	PMJ22J-07-00	Front Support Leg	1
68	G889.1-2000-M10	Lock Nut M10	5

Engine Parts Diagram

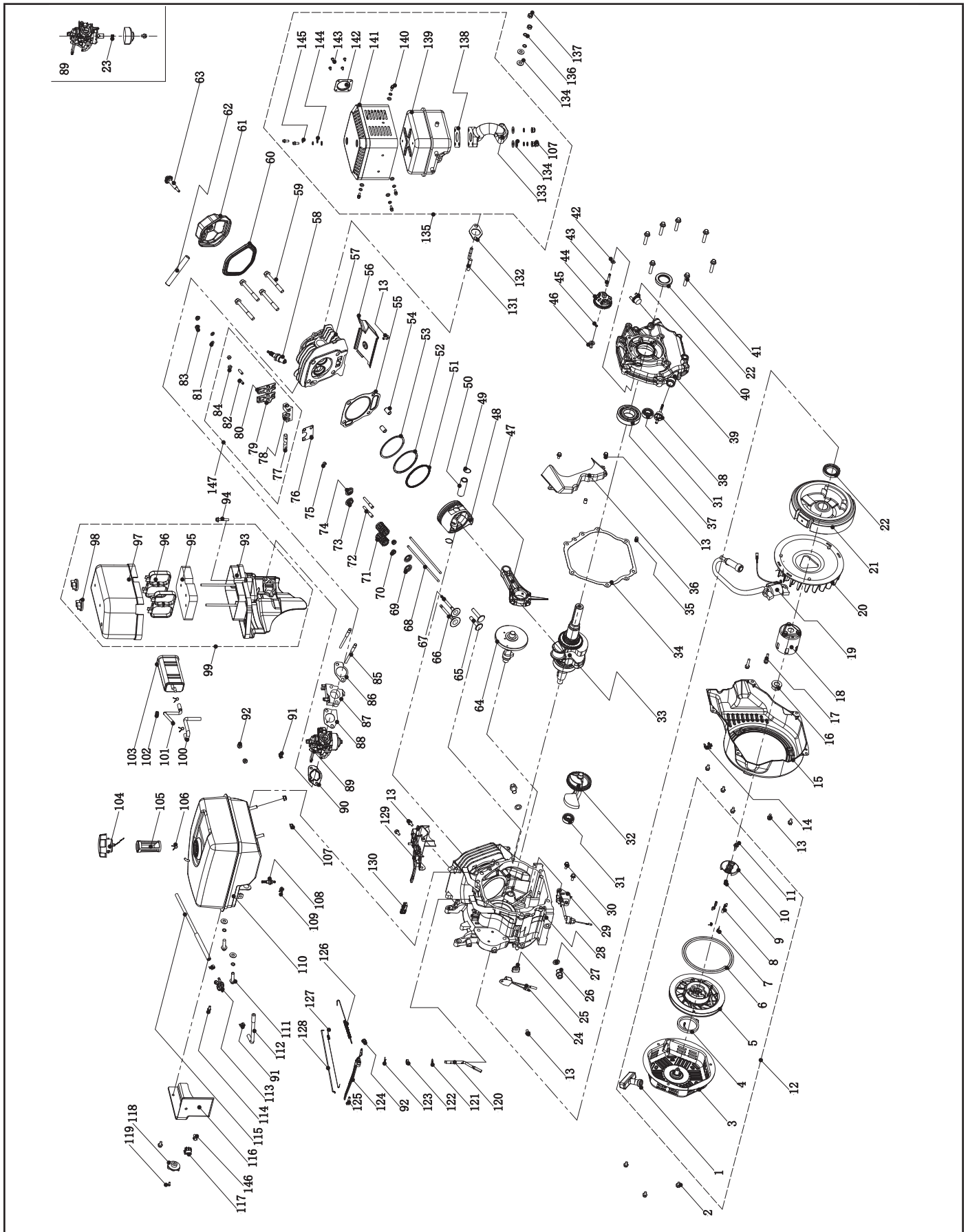

Engine Parts List

#	Part Number	Description	Qty
1	21.061300.00	Handle, Recoil, Soft	1
2	1.5789.0608	Flange Bolt M6 × 8	3
3	46.061100.00.1	Cover, Recoil Starter, Black	1
4	45.060005.00	Spring, Recoil Starter	1
5	45.061102.00	Reel, Recoil Starter	1
6	2.10.003.1	Rope Ø4 x 1550, Black	1
7	45.060003.00	Spring, Ratchet	2
8	45.060002.00	Starter Ratchet, Steel	2
9	45.060009.00	Spring, Ratchet Guide	1
10	45.060007.00	Ratchet Guide	1
11	45.060008.00	Screw, Ratchet Guide	1
12	46.061000.00	Recoil Assembly	1
13	1.5789.0612	Flange Bolt M6 × 12	11
14	2.05.003	Clamp Ø11.5 × 10	1
15	46.080100.00.48	Fan Cover, Yellow	1
16	2.02.007	Nut M16 × 1.5	1
17	1.5789.0629	Flange Bolt M6 × 29	2
18	45.060001.00	Pulley, Starter	1
19	46.123000.01	Ignition Coil	1
20	45.080001.00	Cooling Fan	1
21	46.120100.03	Flywheel	1
22	2.11.007	Oil Seal Ø35 × Ø52 × 8	2
23	46.131017.01	Standard Main Jet	1
	46.131017.01.01	Altitude Main Jet	/
24	21.120400.01	Diode Assembly	1
25	45.030032.00	Sheath, Wire	1
26	2.08.039	Drain Bolt M12 × 1.5 × 15	2
27	2.03.023	Washer Ø12.5 × Ø20 × 2, Drain Bolt	2
28	46.030100.00	Crankcase	1
29	45.127000.02	Oil Level Sensor	1
30	1.5789.0615	Flange Bolt M6 × 15	2
31	1.276.6202	Bearing 6202	2
32	47.050006.00	Weight Balancer	1
33	45.050100.09	Crankshaft, U	1
34	46.030008.00	Gasket, Crankcase Cover	1
35	2.04.001	Dowel Pin Ø9 × 14	2
36	46.080600.00	Air Guide, Right Side	1
37	1.276.6207	Bearing 6207	1
38	46.031000.00.48	Oil Dipstick Assembly, Yellow	1
39	45.030007.01	Cover, Crankcase	1
40	22.031000.01.48	Oil Filler Cap, Yellow	1
41	1.5789.0840	Flange Bolt M8 × 40	7

#	Part Number	Description	Qty
42	2.03.021.1	Washer Ø6.4 × Ø13 × 1, Black	1
43	45.110013.00	Shaft, Governor Gear	1
44	45.110100.00	Gear, Governor	1
45	21.110011.00	Clip, Governor Gear	1
46	45.110012.00	Bushing, Governor Gear	1
47	47.050200.00	Connecting Rod	1
48	46.050005.01	Piston	1
49	2.09.004	Circlip Ø21 × Ø1	2
50	45.050003.00	Pin, Piston	1
51	46.050303.01	Ring, Oil	1
52	46.050302.01	Ring, Second Piston	1
53	46.050301.01	Ring, First Piston	1
54	2.04.004	Dowel Pin Ø12 × 20	2
55	46.030009.00	Gasket, Cylinder Head	1
56	46.080400.00	Air Guide, Lower	1
57	46.010100.00	Cylinder Head	1
58	2.15.002(F6RTC)	Spark Plug F6RTC	1
59	2.08.014	Flange Bolt M10 × 80	4
60	46.020002.00	Gasket, Cylinder Head Cover	1
61	46.021000.00	Cover, Cylinder Head	1
62	45.020001.00	Breather Tube	1
63	45.020100.00	Bolt, Cylinder Head Cover	1
64	46.041000.00	Camshaft	1
65	45.040013.00	Lifter, Valve	2
66	45.040002.00	Valve, Intake	1
67	45.040006.00	Valve, Exhaust	1
68	46.040005.00	Push Rod	2
69	45.040015.00	Retainer, Valve Spring	2
70	45.040017.00	Oil Seal, Valve	2
71	45.040003.00	Spring, Valve	2
72	23.040010.00	Bolt, Rocker Arm	2
73	45.040001.00	Retainer, Intake Valve Spring	1
74	45.040007.00	Retainer, Exhaust Valve Spring	1
75	45.040008.00	Rotator, Exhaust Valve	1
76	46.040004.00	Guide Plate, Push Rod	1
77	46.040016.00	Shaft, Rocker Arm	1
78	46.040201.00	Retainer, Rocker Arm	1
79	46.040009.00	Rocker Arm, Intake Valve	1
80	46.040018.00	Rocker Arm, Exhaust Valve	1
81	1.97.1.06	Washer Ø6	2

#	Part Number	Description	Qty
82	22.040012.00	Screw, Valve Adjustment	2
83	1.6177.1.06	Flange Nut M6	2
84	21.040021.00	Nut M6 × 0.5, Lock	2
85	2.01.013	Stud Bolt M6 × M8 × 131	2
86	46.130002.20	Gasket, Insulator	1
87	45.130001.01	Insulator, Carburetor	1
88	46.130003.00	Gasket, Carburetor	1
89	46.131000.01	Carburetor	1
	46.131000.03		
90	45.130004.00	Gasket, Air Cleaner	1
91	2.06.007	Clamp Ø8 × b6	3
92	1.6177.06	Flange Nut , M6	3
93	46.091100.01	Base, Air Cleaner	1
94	1.5789.0633	Flange Bolt M6 × 33	1
95	46.091003.02	Element, Air Cleaner	1
96	46.091102.02	Supporter, Air Cleaner	2
97	46.091200.02	Cover, Air Cleaner	1
98	46.091600.01	Screw Cap, Air Cleaner Cover	2
99	46.091000.02	Air Cleaner Assembly	1
100	46.070013.00	Pipe, Air Cleaner	1
101	46.070014.00	Pipe, Reversal Valve	1
102	2.12.001	Buffer Ø7.5 × 7.5	1
103	46.070700.00	Carbon Canister,150CC	1
104	24.070100.02	Cap, Fuel Tank	1
105	46.070300.00	Fuel Filter, Fuel Tank	1
106	2.06.006	Clamp Ø7 × Ø1	3
107	1.6187.1.08	Nut M8	5
108	21.070600.03	Connector, Zinc Alloy	1
109	2.06.016	Clamp Ø8.7 × b8	1
110	46.071000.01.1	Fuel Tank, Black	1
111	1.5789.0832	Flange Bolt M8 × 32	2
112	46.070011.00	Pipe, Fuel Tank To Fuel Valve	1
113	24.070400.00	Fuel Valve	1
114	1.16674.0512.2	Flange Bolt M5 × 12	1
115	46.070011.01	Pipe, Fuel Valve To Carburetor	1
116	46.070010.00	Veil, Fuel Tank	1
117	5.1010.003.3	Ignition Switch, Red	1
118	24.070001.00	Knob, Fuel Valve	1
119	1.818.0412	Bolt M4X12	1
120	45.110001.00	Shaft, Governor Arm	1
121	2.03.019	Washer Ø8.2 × Ø17 × 0.8	1
122	2.11.006	Oil Seal Ø7 × Ø14 × 5	1
123	45.110008.00	Pin, Shaft	1

#	Part Number	Description	Qty
124	45.110003.00	Arm, Governor	1
125	2.08.040	Bolt M6 × 21, Governor Arm	1
126	45.110007.00	Spring, Governor	1
127	45.110005.00	Spring, Throttle Return	1
128	45.110006.00	Rod, Governor	1
129	46.080300.00	Air Guide, Upper	1
130	24.111008.01.48	Sheath, Grip	1
131	2.01.005	Stud Bolt M8 × 49	2
132	46.100001.07	Gasket, Exhaust Pipe	1
133	46.101001.05	Exhaust Pipe	1
134	1.848.08	Washer Ø8	7
135	46.101000.05.2	Muffler Assembly, Black	1
136	1.93.08	Lock Washer Ø8	7
137	1.6175.08	Nut M8	2
138	46.101002.05	Washer, Muffler	1
139	46.101100.05	Muffler Assembly	1
140	1.16674.0510	Flange Bolt M5 × 10	6
141	46.101202.05	Muffler Protector	1
142	46.101300.05	Muffler Screen	1
143	1.818.046	Screw M4 × 6	4
144	1.848.05	Washer Ø5	6
145	1.859.05	Lock Washer Ø5	6
146	1.5789.0612.3	Flange Bolt M6 × 12	2
147	46.040200.00	Rocker Arm Assembly	1

TROUBLESHOOTING

Problem	Cause	Solution
Engine will not start	No fuel	Add fuel
	Faulty spark plug	Replace spark plug
	Unit loaded during startup	Remove load from unit
Engine starts but runs roughly	Low oil level	Fill crankcase to the proper level
		Place log splitter on a flat, level surface
	Choke in the wrong position	Adjust choke
	Spark plug wire loose	Attach wire to spark plug
Engine shuts down during operation	Out of fuel	Fill fuel tank
	Low oil level	Fill crankcase to the proper level
		Place log splitter on a flat, level surface
Engine cannot supply enough power or overheating	Insufficient ventilation	Check for air restriction. Move to a well ventilated area
Wedge movement is slow or erratic	Air in the hydraulic oil system	Purge air by extending and retracting the wedge several times until motion is smooth
	Debris lodged in beam guides	Clear debris from beam
	Low hydraulic oil	Check oil level and add as needed
Oil leak from hose connection	Loose hose clamp or hydraulic fitting	Tighten hose clamp or hydraulic fitting
Oil leak from cylinder	Faulty cylinder rod seal	Contact Customer Service
	Scored or bent cylinder rod	Contact Customer Service
	Loose hydraulic fitting	Tighten hydraulic fitting
	Faulty combination washer seal on cylinder hydraulic fitting	Contact Customer Service
Wedge will not extend or retract	Faulty control valve	Contact Customer Service
	Faulty hydraulic pump	Contact Customer Service
	Low hydraulic oil	Check oil level and add as needed
Wedge does not Auto-Return	Low hydraulic oil	Check oil level and add as needed
	Faulty control valve	Contact Customer Service
Excessive bouncing while towing	Under-inflated tires	Inflate tires to proper pressure. Refer to tire sidewall

For further technical support:

Technical Support Team
 Mon-Fri 8:30 AM-5:00 PM (PST/PDT)
 Toll Free 1-877-338-0999
support@championpowerequipment.com

WARRANTY*

CHAMPION POWER EQUIPMENT
2 YEAR LIMITED WARRANTY

Warranty Qualifications

To register your product for warranty and FREE lifetime call center technical support please visit:

<https://www.championpowerequipment.com/register>

To complete registration you will need to include a copy of the purchase receipt as proof of original purchase. Proof of purchase is required for warranty service. Please register within ten (10) days from date of purchase.

Repair/Replacement Warranty

CPE warrants to the original purchaser that the mechanical and electrical components will be free of defects in material and workmanship for a period of two years (parts and labor) from the original date of purchase and 180 days (parts and labor) for commercial and industrial use. Transportation charges on product submitted for repair or replacement under this warranty are the sole responsibility of the purchaser. This warranty only applies to the original purchaser and is not transferable.

Do Not Return The Unit To The Place Of Purchase

Contact CPE's Technical Service and CPE will troubleshoot any issue via phone or e-mail. If the problem is not corrected by this method, CPE will, at its option, authorize evaluation, repair or replacement of the defective part or component at a CPE Service Center. CPE will provide you with a case number for warranty service. Please keep it for future reference. Repairs or replacements without prior authorization, or at an unauthorized repair facility, will not be covered by this warranty.

Warranty Exclusions

This warranty does not cover the following repairs and equipment:

Normal Wear

Products with mechanical and electrical components need periodic parts and service to perform well. This warranty does not cover repair when normal use has exhausted the life of a part or the equipment.

Installation, Use and Maintenance

This warranty will not apply to parts and/or labor if the product is deemed to have been misused, neglected, involved in an accident, abused, loaded beyond the product's limits, modified, installed improperly or connected incorrectly to any electrical component. Normal maintenance is not covered by this warranty and is not required to be performed at a facility or by a person authorized by CPE.

Other Exclusions

This warranty excludes:

- Cosmetic defects such as paint, decals, etc.
- Wear items such as filter elements, o-rings, etc.
- Accessory parts such as hoses, storage covers, etc.
- Failures due to acts of God and other force majeure events beyond the manufacturer's control.
- Problems caused by parts that are not original Champion Power Equipment parts.

Limits of Implied Warranty and Consequential Damage

Champion Power Equipment disclaims any obligation to cover any loss of time, use of this product, freight, or any incidental or consequential claim by anyone from using this product. THIS WARRANTY AND THE ATTACHED U.S. EPA and/or CARB EMISSION CONTROL SYSTEM WARRANTIES (WHEN APPLICABLE) ARE IN LIEU OF ALL OTHER WARRANTIES, EXPRESS OR IMPLIED, INCLUDING WARRANTIES OF MERCHANTABILITY OR FITNESS FOR A PARTICULAR PURPOSE.

This warranty gives you certain legal rights which may change from state to state or province to province. Your state or province may also have other rights you may be entitled to that are not listed within this warranty.

Contact Information

Address

Champion Power Equipment, Inc.
12039 Smith Ave.
Santa Fe Springs, CA 90670 USA
www.championpowerequipment.com

Customer Service

Mon – Fri 8:30 AM – 5:00 PM (PST/PDT)
Toll Free: 1-877-338-0999
info@championpowerequipment.com
Fax no.: 1-562-236-9429

Technical Service

Mon – Fri 8:30 AM – 5:00 PM (PST/PDT)
Toll Free: 1-877-338-0999
tech@championpowerequipment.com
24/7 Tech Support: 1-562-204-1188

**CHAMPION POWER EQUIPMENT, INC. (CPE),
THE UNITED STATES ENVIRONMENT PROTECTION AGENCY (U.S. EPA)
AND THE CALIFORNIA AIR RESOURCES BOARD (CARB) EMISSION CONTROL SYSTEM WARRANTY**

Your Champion Power Equipment (CPE) engine complies with both the U.S. EPA and state of California Air Resources Board (CARB) Exhaust and Evaporative emissions regulations.

YOUR WARRANTY RIGHTS AND OBLIGATIONS:

The US EPA, California Air Resources Board, and CPE are pleased to explain the Federal and California Exhaust and Evaporative Emission Control Systems Warranty on your 2020 small off-road engine (SORE) and engine powered equipment. In California, new equipment that use small off-road engines (SORE) must be designed, built and equipped to meet the State's stringent anti smog standards. In the other states, new engines and equipment must be designed, built and equipped, at the time of sale, to meet U.S. EPA regulations for small off-road engines (SORE). CPE must warrant the exhaust and evaporative emission control system on your small off-road engine (SORE) for the period listed below, provided there has been no abuse, neglect, unapproved modification, or improper maintenance of your equipment leading to the failure of the exhaust and evaporative emission control systems.

Your evaporative emission control system may include parts such as: carburetors, fuel tanks, fuel lines, (for liquid fuel and fuel vapors), fuel caps, valves, canisters, filters, clamps, connectors, and other associated components. Also included for your exhaust emission control system may be fuel-injection system, the ignition system, catalytic converter and other exhaust emission related assemblies. Where a warrantable condition exists, CPE will repair your small off-road engine (SORE) at no cost to you including diagnosis, parts and labor.

MANUFACTURER'S WARRANTY COVERAGE:

This exhaust and evaporative emission control system is warranted for two years. If any exhaust and evaporative, emission related part on your engine or equipment is defective in, the part will be repaired or replaced by CPE.

OWNER WARRANTY RESPONSIBILITIES:

As the small off-road engine (SORE) owner, you are responsible for the performance of the required maintenance listed in your Owner's Manual. CPE recommends that you retain all your receipts covering maintenance on your small off-road engine (SORE), but CPE cannot deny warranty coverage solely for the lack of receipts.

As the small off-road engine (SORE) owner, you should be aware that CPE may deny you warranty coverage if your small, off-road engine (SORE) or a part has failed due to abuse, neglect, improper maintenance or unapproved modifications.

You are responsible for presenting your small off-road engine to an Authorized CPE distribution center, service center or alternative service outlet as described in (3)(f.) below or CPE dealer or CPE, Santa Fe Springs, Ca. as soon as the problem exists. The warranty repairs shall be completed in a reasonable amount of time, not to exceed 30 days.

If you have any questions regarding your warranty coverage, you should contact:

Champion Power Equipment, Inc.
Customer Service
12039 Smith Ave.
Santa Fe Springs, CA 90670
1-877-338-0999
tech@championpowerequipment.com

EXHAUST AND EVAPORATIVE EMISSION CONTROL SYSTEM WARRANTY

The following are specific provisions relative to your Exhaust and Evaporative Emission Control System (ECS) Warranty Coverage.

- 1. APPLICABILITY:** This warranty shall apply to 1995 and later model year California small off-road engines (SORE) (for other states, 1997 and later model year engines). The ECS Warranty Period shall begin on the date the new engine or equipment is delivered to its original, end-use purchaser, and shall continue for 24 consecutive months thereafter.
- 2. GENERAL EMISSIONS WARRANTY COVERAGE**

CPE warrants to the original, end-use purchaser of the new engine or equipment and to each subsequent purchaser that each of its small off-road engines (SORE) is:

 - 2a. Designed, built and equipped to conform to U.S. EPA emissions standards for spark-ignited engines at or below 19 kilowatts and all applicable regulations adopted by the California Air Resources Board, and
 - 2b. Free from defects in materials and workmanship that cause the failure of a warranted part to be identical in all material respects to the part as described in the engine manufacturer's application for certification for a period of two years.
- 3. THE WARRANTY ON EXHAUST AND EVAPORATIVE EMISSION-RELATED PARTS WILL BE INTERPRETED AS FOLLOWS:**
 - 3a. Any warranted part that is not scheduled for replacement as required maintenance in the Owners Manual shall be warranted for the ECS Warranty Period. If any such part fails during the ECS Warranty Period, it shall be repaired or replaced by CPE according to Subsection "d" below. Any such part repaired or replaced under the ECS Warranty shall be warranted for any remainder of the ECS Warranty Period.
 - 3b. Any warranted, exhaust and evaporative emissions-related part which is scheduled only for regular inspection as specified in the Owners Manual shall be warranted for the ECS Warranty Period. A statement in such written instructions to the effect of "repair or replace as necessary", shall not reduce the ECS Warranty Period. Any such part repaired or replaced under the ECS Warranty shall be warranted for the remainder of the ECS Warranty Period.
 - 3c. Any warranted, exhaust and evaporative emissions-related part which is scheduled for replacement as required maintenance in the Owner's Manual shall be warranted for the period of time prior to the first scheduled replacement point for that part. If the part fails prior to the first scheduled replacement, the part shall be repaired or replaced by CPE according to Subsection "d" below. Any such exhaust and evaporative emissions-related part repaired or replaced under the ECS Warranty, shall be warranted for the remainder of the ECS Warranty Period prior to the first scheduled replacement point for such emissions-related part.
 - 3d. Repair or replacement of any warranted, exhaust and evaporative emissions-related part under this ECS Warranty shall be performed at no charge to the owner at a CPE Authorized Service Outlet.
 - 3e. The owner shall not be charged for diagnostic labor which leads to the determination that a part covered by the ECS Warranty is in fact defective, provided that such diagnostic work is performed at a CPE Authorized Service Outlet.
 - 3f. CPE shall pay for covered exhaust and evaporative emissions warranty repairs at non-authorized service outlets under the following circumstances:
 - i. The service is required in a population center with a population over 100,000 according to U.S. Census 2000 without a CPE Authorized Service Outlet AND
 - ii. The service is required more than 100 miles from a CPE Authorized Service Outlet. The 100 mile limitation does not apply in the following states: Alaska, Arizona, Colorado, Hawaii, Idaho, Montana, Nebraska, Nevada, New Mexico, Oregon, Texas, Utah and Wyoming.
 - 3g. CPE shall be liable for damages to other original engine components or approved modifications proximately caused by a failure under warranty of an emission-related part covered by the ECS Warranty.
 - 3h. Throughout the ECS Warranty Period, CPE shall maintain a supply of warranted exhaust and evaporative emission-related parts sufficient to meet the expected demand for such exhaust and evaporative emission-related parts.
 - 3i. Any CPE Authorized and approved exhaust and evaporative emission-related replacement part may be used in the performance of any ECS Warranty maintenance or repair and will be provided without charge to the owner. Such use shall not reduce CPE's warranty obligation.
 - 3j. Unapproved add-on or modified parts may not be used to modify or repair a CPE engine. Such use voids this ECS Warranty and shall be sufficient grounds for disallowing an ECS Warranty claim. CPE shall not be liable hereunder for failures of any warranted parts of a CPE engine caused by the use of such an unapproved add-on or modified part.

EMISSION-RELATED PARTS INCLUDE THE FOLLOWING: (using those portions of the list applicable to the engine)

Systems covered by this warranty	Parts Description
Fuel Metering System	Fuel regulator, Carburetor and internal parts
Air Induction System	Air cleaner, Intake manifold
Ignition System	Spark plug and parts, Magneto ignition system
Exhaust System	Exhaust manifold, catalytic converter
Miscellaneous Parts	Tubing, Fittings, Seals, Gaskets, and Clamps associated with these listed systems.
Evaporative Emissions	Fuel Tank, Fuel Cap, Fuel Lines (for liquid fuel and fuel vapors), Fuel Line Fittings, Clamps, Pressure Relief Valves, Control Valves, Control Solenoids, Electronic Controls, Vacuum Control Diaphragms, Control Cables, Control Linkages, Purge Valves, Gaskets, Liquid/Vapor Separator, Carbon Canister, Canister Mounting Brackets, Carburetor Purge Port Connector

TO OBTAIN WARRANTY SERVICE:

You must take your CPE engine or the product on which it is installed, along with your warranty registration card or other proof of original purchase date, at your expense, to any Champion Power Equipment dealer who is authorized by Champion Power Equipment, Inc. to sell and service that CPE product during his normal business hours. Alternate service locations defined in Section (3)(f.) above must be approved by CPE prior to service. Claims for repair or adjustment found to be caused solely by defects in material or workmanship will not be denied because the engine was not properly maintained and used.

If you have any questions regarding your warranty rights and responsibilities, or to obtain warranty service, please write or call Customer Service at Champion Power Equipment, Inc.

Champion Power Equipment, Inc.
12039 Smith Ave.
Santa Fe Springs, CA 90670
1-877-338-0999
Attn.: Customer Service
tech@championpowerequipment.com