

CERTIFIED™/MC

model number 060-3732-6 | Contact us: 1-844-428-7277

22" 2-STAGE SNOWBLOWER

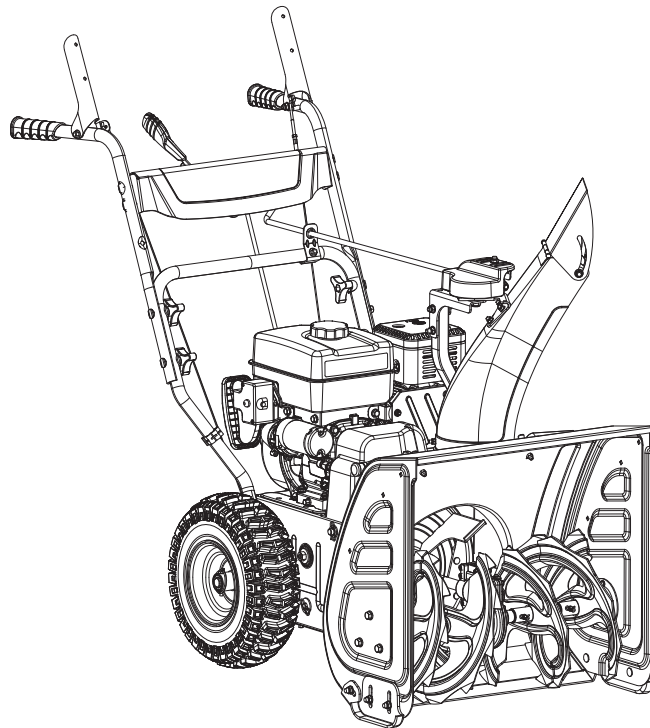

IMPORTANT:

Please read this manual carefully before running this snowblower and save it for reference.

INSTRUCTION MANUAL

IF ANY PARTS ARE MISSING OR DAMAGED, OR IF YOU HAVE ANY QUESTIONS, PLEASE CALL OUR TOLL-FREE HELPLINE AT 1-844-428-7277



Read and understand this instruction manual thoroughly before using the product. It contains important information for your safety as well as operating and maintenance advice.

Keep this instruction manual for future use. Should this product be passed on to a third party, this instruction manual must be included.

This Certified product carries a two (2) year warranty against defects in workmanship and materials. At its discretion, Certified Canada agrees to have any defective part(s) repaired or replaced free of charge, within the stated warranty period, when returned by the original purchaser with proof of purchase. This product is not guaranteed against wear or breakage due to misuse and/or abuse.

TABLE OF CONTENTS

- WARRANTY INFORMATION..... 2
- TABLE OF CONTENTS 3
- SAFETY INFORMATION..... 4
 - General Safety 4
 - Preparation For Use 4
 - Safe Handling of Gasoline 4
 - Operation 5
 - Clearing a Clogged Discharge Chute 6
 - Maintenance and storage 6
 - Safety Definitions 7
 - Safety Symbols..... 7
 - Operation Symbols 8
- FEATURES..... 10
 - Know Your Snowblower 10
 - Engine..... 10
- ASSEMBLY 12
 - Unpacking 12
 - Additional Parts..... 12
 - Tools Required..... 12
 - Assembly Parts 12
 - Assembly..... 15
 - Wheels And Shoes 15
 - Handle 16
 - Speed Control Connecting Lever 17
 - Self-Drive Control Wire and Auger Control Wire..... 18
 - Snow Discharge Support 18
 - Snow Discharge Chute..... 18
 - Discharge Chute Rotation Lever 19
- OPERATION 20
 - Before Operation..... 20
 - Check the General Condition..... 20
 - Check the Engine 20
 - Operation 20
 - Starting the Engine 20
 - Stopping the Engine 22
 - Operating the Machine 22
 - Control Levers 22

- Drive System..... 22
- Adjusting the Snow Discharge Direction and Height..... 23
- Adjusting the Snow Shoes..... 24
 - To Adjust the Shoes 24
 - After Use 25
- Servicing 25
 - Safety Precautions..... 25
- MAINTENANCE 25
 - Maintenance 26
 - Regular Service Periods 26
 - Refueling..... 26
 - Adding Fuel 27
 - Oil Change 28
 - Replacing Shear Pins 28
 - Adjusting Self-Drive Control Handle Cable 29
 - Adjusting Auger Control Cable..... 29
 - Replace Traction Drive Belt..... 30
 - Repair Or Replace Friction Disk..... 32
 - Lubrication..... 33
 - Storage..... 34
 - Transporting..... 34
- SPECIFICATIONS 35
 - Specifications 35
 - Snowblower Specifications..... 35
 - Engine Specifications..... 35
 - Oil Specifications 35
 - Fuel Specifications..... 35
 - Parts Diagram 36
 - Parts List..... 37
 - Engine Parts Diagram..... 42
 - Engine Parts List..... 43
- TROUBLESHOOTING 46
 - Troubleshooting 46
 - Additional Limitations..... 47
 - Notice To Consumer..... 47

SAVE THESE INSTRUCTIONS

This manual contains important safety and operating instructions. Read all instructions and follow them with use of this product.

GENERAL SAFETY

1. Read the operating and service instruction manual carefully. Be thoroughly familiar with the controls and the proper use of the equipment. Know how to stop the unit and disengage the controls quickly.
2. Never allow children under 16 years old to operate the equipment. Never allow adults to operate the equipment without proper instruction.
3. Thrown objects can cause serious injury. Keep the area of operation clear of all persons, particularly small children, and pets. Plan your snow discharge pattern to prevent throwing material toward cars, structures, roads and people.
4. Exercise caution to avoid slipping or falling, especially when operating in reverse.
5. Keep in mind that the operator or user is responsible for accidents or hazards occurring to other people or their property.
6. Never use the snowblower under the influence of alcohol or medication, or if you are tired or ill.

PREPARATION FOR USE

1. Thoroughly inspect the area where the equipment is to be used and remove all doormats, sleds, boards, wires, and other foreign objects.
2. Disengage all clutch handles before starting the motor.
3. Do not operate the equipment without wearing adequate winter garments. Wear footwear which will improve footing on slippery surfaces.
4. Adjust the auger housing height to clear gravel or crushed rock surface.

5. Never attempt to make any adjustments while the engine is running (except where specifically recommended in the manual).
6. Let engine and machine adjust to outdoor temperatures before starting to clear snow.
7. The operation of any powered machine can result in foreign objects being thrown into the eyes. Always wear safety glasses or eye shields during operation, or while performing an adjustment or repair.

SAFE HANDLING OF GASOLINE

To avoid severe injury or property damage use high levels of care while handling gasoline. Gasoline is an extremely flammable substance and the vapours are explosive. Serious personal injury can occur when gasoline is spilled on yourself or your clothes, which can ignite. If you come into contact with gasoline, wash affected areas of skin and change clothing immediately.

1. Use only an approved gasoline container.
2. Extinguish all cigarettes, cigars, pipes and other sources of ignition prior to working with or near gasoline.
3. Never refuel machine within closed spaces.
4. Never remove gas cap or add fuel while the engine is hot or running.
5. Allow engine to cool at least two minutes before refueling.
6. Do not over fill fuel tank. Keep fuel level at least ½ inch below bottom of filler neck to provide space for fuel expansion.
7. Replace gasoline cap and tighten securely.
8. If gasoline is spilled, wipe it off the engine and equipment. Move machine to another area. Wait 5 minutes before starting the engine.

9. Never store the machine or fuel container inside where there is an open flame, spark or pilot light (e.g. furnace, water heater, space heater, clothes dryer etc.).
10. Allow machine to cool at least 5 minutes before storing.
11. Never fill containers inside a vehicle or on a truck or trailer bed with a plastic liner. Always place containers on the ground away from your vehicle before filling.
12. If possible, remove gas-powered equipment from the truck or trailer and refuel it on the ground. If this is not possible, then refuel such equipment on a trailer with a portable container, rather than from a gasoline dispenser nozzle.
13. Keep the nozzle in contact with the rim of the fuel tank or container opening at all times until fueling is complete. Do not use gas cans with nozzle lock-open devices.

OPERATION

1. Do not put hands or feet near or under rotating parts. Keep clear of the discharge opening at all times.
2. Exercise extreme caution when operating on or crossing gravel drives, walks, or roads. Stay alert for hidden hazards or traffic.
3. After striking a foreign object, stop the engine, remove the spark plug, thoroughly inspect the snowblower for any damage, and repair the damage before restarting and operating the snowblower.
4. If the unit should start to vibrate abnormally, stop the engine and check immediately for the cause. Vibration is generally a warning of trouble. Vibration typically indicates a mechanical problem has occurred.
5. Stop the engine whenever you leave the operating position, before unclogging the auger housing or discharge guide, and when making any repairs, adjustments, or inspections.
6. Before cleaning, inspecting or repairing any parts of the snowblower ensure the auger has stopped moving. Disconnect the spark plug wire and keep it away from the plug to prevent accidental starting.
7. Before leaving the machine unattended, disengage all control levers, stop the engine and remove the safety key.
8. Do not run the engine indoors. Exhaust fumes are dangerous.
9. Do not clear snow across the face of slopes. Exercise extreme caution when changing direction on slopes. Do not attempt to clear steep slopes.
10. Never operate the snowblower without proper guards, plates or other safety protective devices in place.
11. Never operate the snowblower near glass enclosures, automobiles, window wells, etc., without proper adjustment of the snow discharge angle. Keep children and pets away.
12. Do not overload the machine capacity by attempting to clear snow at too fast a rate.
13. Never operate the machine at high transport speeds on slippery surfaces. Use care when reversing.
14. Never direct discharge at bystanders or allow anyone in front of the unit.
15. Disengage power to the impeller when snowblower is transported or not in use.

16. Use only attachments and accessories approved by the manufacturer of snowblower (such as wheel weights, counterweights, cabs, etc.).
17. Never operate the snowblower without good visibility or light. Always be sure of your footing, and keep a firm hold on the handles. Walk; never run.
18. Take all possible precautions when leaving the machine unattended. Disconnect the power take-off and stop the engine.
19. Keep all nuts, bolts and screws tight to be sure the equipment is in safe working condition;
20. Replace worn or damaged parts for safety; Use only genuine replacement parts and accessories.
21. This snowblower is not intended for use by persons (including children) with reduced physical, sensory or mental capabilities, or lack of experience and knowledge, unless they have been given supervision or instruction concerning use of the appliance by a person responsible for their safety.
22. Be careful while working on the machine or clearing a blockage in the auger or impeller to ensure that fingers and hands do not become crushed or cut.
23. Do not touch hot engine components like the muffler, muffler guard or engine block during operation of the snowblower as they will cause burns.

CLEARING A CLOGGED DISCHARGE CHUTE

Hand contact with the rotating impeller inside the discharge chute is the most common cause of injury associated with snowblowers. Never use your hand to clean out the discharge chute.

To clear the chute:

1. **SHUT THE ENGINE OFF!**
2. Wait 10 seconds to be sure the impeller blades have stopped rotating.
3. Always use a clean-out tool. **DO NOT** use your hands.

MAINTENANCE AND STORAGE

1. Check shear bolts, engine mounted bolts, etc., at frequent intervals for proper tightness to sure the equipment is in safe, working condition.
2. Never store the machine with fuel in the fuel tank inside a building where ignition sources are present such as hot water heaters, space heaters, clothes dryers or any open flame sources. Allow the engine to cool before storing in any enclosure.
3. Always refer to owner's guide instructions for important details if the snowblower is to be stored for an extended period.
4. Maintain or replace safety and instructions labels, as necessary.
5. Run the snowblower for one minute to clear out packed snow and ice to prevent freeze-up during storage.

SAFETY DEFINITIONS

⚠ DANGER
DANGER indicates a hazardous situation which, if not avoided, will result in death or serious injury.



⚠ WARNING
WARNING indicates a hazardous situation which, if not avoided, could result in death or serious injury.







⚠ CAUTION
CAUTION indicates a hazardous situation which, if not avoided, could result in minor or moderate injury.





NOTICE
NOTICE is used to address practices not related to physical injury.

SAFETY SYMBOLS

Some of the following symbols may be used on this product. Please study them and learn their meaning. Proper interpretation of these symbols will allow you to more safely operate the product.









Symbol	Name	Designation/Explanation
	Read the Instruction Manual	To reduce the risk of injury, user must read and understand the instruction manual before using this product.
	Eye and Ear Protection	Always wear safety goggles or safety glasses with side shields, and as necessary a full face-shield as well as full ear protection when operating this product. Always wear eye protection with side shields marked to comply with ANSI Z87.1.







Symbol	Name	Designation/Explanation
	Safety Alert	This machine was built to be operated according to the safe operation practices in this manual. As with any type of power equipment, carelessness or error on the part of the operator can result in serious injury. This machine is capable of amputating fingers, hands, toes and feet and throwing foreign objects. Failure to observe the safety instructions could result in serious injury or death.
	Electric Shock	Failure to use the starter in dry conditions and to observe safe practices can result in electric shock.
	Risk of Fire	Fuel and its vapours are extremely flammable and explosive. Fire can cause severe burns or death. Do not add fuel while the product is operating or still hot.
	Toxic Fumes	The engine exhaust from this product contains chemicals known to cause cancer, birth defects and other reproductive harm.
	Risk of Asphyxiation	This engine emits carbon monoxide, an odourless, colourless poison gas. Breathing carbon monoxide can cause nausea, fainting or death. Use only in a well-ventilated area.
	Thrown Objects	This machine may pick up and throw objects which can cause serious personal injury.
	Always Use Chute Tool	Never use your hands to clear a clogged chute assembly. Shut OFF engine and remain behind handles until all moving parts have stopped before unclogging.

Symbol	Name	Designation/Explanation
	Hot Surface	Exhaust gases, muffler and engine components are extremely HOT and cause burns.
	Risk of Fire	Fuel and its vapours are extremely flammable and explosive. Fire can cause severe burns or death. Do not add fuel while the product is operating or still hot.
	Rotating Auger	DANGER: Avoid injury from rotating auger - keep feet away.
	Rotating Blades	Never put your hand in the chute. Contact with rotating parts can amputate fingers and hands.

OPERATION SYMBOLS

Some of the following symbols may be used on this product. Please study them and learn their meaning. Proper interpretation of these symbols will allow you to more safely operate the product.

Symbol	Name	Designation/Explanation
	Engine Start	Follow steps to start engine.
	Check Oil Level	Recommended oil is 0W-30. The engine can be seriously damaged without oil. Always check the oil level before using. The machine must be resting firmly on level ground when checking.
	Check Fuel Level	Use clean, fresh, regular unleaded gasoline with a minimum octane rating of 85 and an ethanol content of less than 10% by volume.
	Fuel Valve: ON	Move the fuel valve lever to the on position.
	Choke: ON	To start a cold engine, move the choke lever to the choke position.
	Throttle: Full Speed	Move the throttle lever to full speed to start the engine.
	Insert Engine Key	Make sure the engine safety key is inserted into the key hole.
	Cold Prime	To start a cold engine, prime 3-5 times.

Symbol	Name	Designation/Explanation
	Warm Prime	To start a warm engine, DO NOT prime.
	Recoil Start	Pull the recoil starter grip to start manually.
	Choke: OFF	When the engine starts, move the choke to run position.
	Instruction Manual	See instruction manual for details on using the electric start feature.
	Stop	Follow steps to stop.
	Fuel Valve: OFF	Move the fuel valve lever to the OFF position.
	Remove Engine Key	Remove the engine key.

KNOW YOUR SNOWBLOWER

- 1 Self-Drive Control Handle
- 2 Upper Handles
- 3 Speed Control Connecting Lever
- 4 Handle Locking Knobs
- 5 Lower Handle
- 6 Wheels
- 7 Auger Housing
- 8 Adjustable Skid Shoes
- 9 Auger
- 10 Discharge Chute
- 11 Discharge Deflector
- 12 Discharge Chute Rotation Lever
- 13 Discharge Chute Lever Guide
- 14 Auger Control Handle
- 15 Speed Adjusting Handle
- 16 Clean Out Tool

ENGINE

- 1 Key (safety lock out)
- 2 Primer Bulb
- 3 Throttle Lever
- 4 Choke Lever
- 5 Fuel Valve (On/Off)
- 6 Fuel Cap
- 7 Electric Start Button
- 8 Recoil Starter Grip
- 9 Oil Fill and Level Check Cap
- 10 Oil Drain Plug

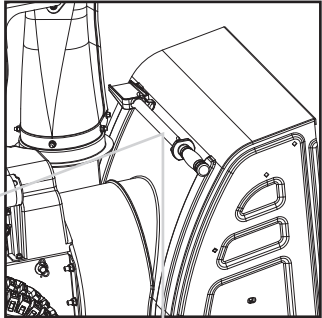
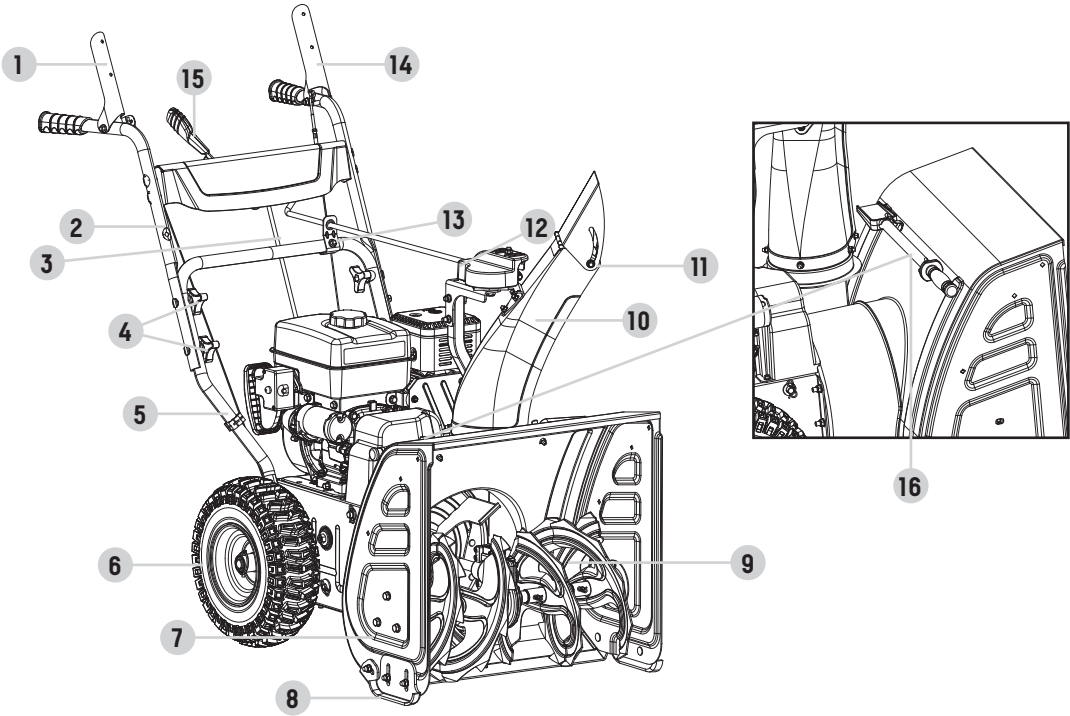

FEATURES

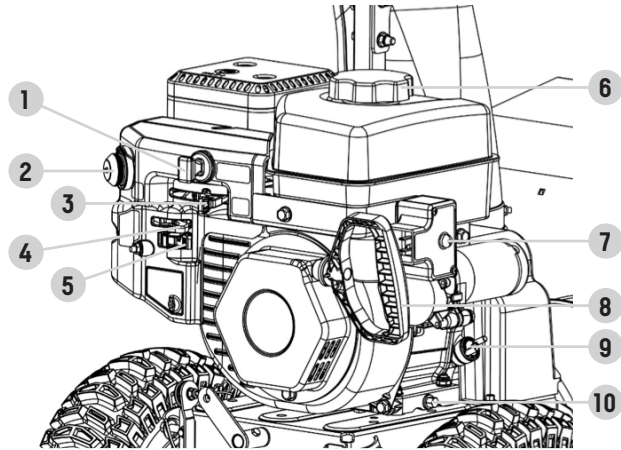

UNPACKING

1. Set the shipping carton on a solid, flat surface.
2. Remove everything from the carton except the snowblower base — including upper and lower handles, wheels, connecting levers, chute, hardware, etc. Make sure all the assembly parts are included before you start.
3. Lift the top half of the box off and the base should be clear to start assembly.
4. Cut down the bottom carton to allow a flat surface area to install the assembly parts without scratching parts or cutting tires. Alternatively, with team lift help, lift the base of the snowblower out of the carton and place it on a flattened carton to start assembly.
5. Now you are ready for assembly.



ADDITIONAL PARTS





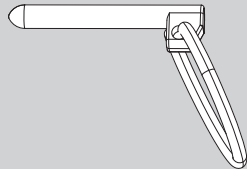
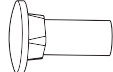

Part	Part Qty.	Usage
Shear Pin (for auger)	4	Spare part
Clip (for auger)	4	Spare part
Starter Electric Cord	1	Accessory

TOOLS REQUIRED

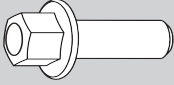
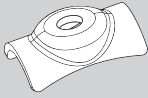
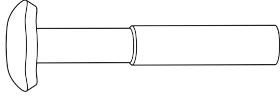
Tool	Size
Wrench (included)	10, 12
Cross-head Screwdriver (not included)	Standard

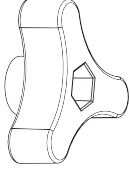

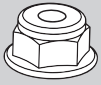
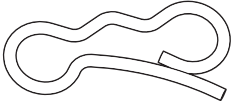
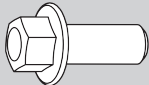

ASSEMBLY PARTS

Part	Part Qty.	Hardware Needed	Hardware Qty.	Hardware Reference	Tool(s) Needed
Wheels	2	Spring lock pin (1-3)	2		N/A
Shoes	2	M8×20 Carriage bolt (1-4)	4		Size 12 Wrench
		M8 All-metal hexagon flange locking nut (1-5)	4		

Part	Part Qty.	Hardware Needed	Hardware Qty.	Hardware Reference	Tool(s) Needed
Lower handle	1	M8×45 Hexagon flange bolt (2-2)	2		Size 12 Wrench
	1	M8×20 Hexagon flange bolt (2-3)	2		Size 12 Wrench
		Shaped washer (2-4)	2		N/A
Upper handle	1	M8×52 Flat head bolts (2-5)	4		N/A
		Curved washer (2-6)	4		N/A
		Locking knob V (2-7)	4		N/A
Discharge chute bracket	1	M8×45 Hexagon flange bolt (2-8)	1		Size 12 Wrench
		M8 All-metal hexagon flange lock nut (2-9)	1		Size 12 Wrench
Speed control connecting lever	1	Lock Pin (3-1)	2		N/A
Snow discharge support	1	M6×20 Hexagon flange bolt (preassembled) (4-1)	2		Size 10 Wrench
		M6 All-metal hexagon flange lock nut (preassembled) (4-2)	3		Size 10 Wrench

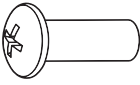
ASSEMBLY

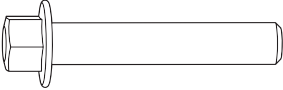
ASSEMBLY

Part	Part Qty.	Hardware Needed	Hardware Qty.	Hardware Reference	Tool(s) Needed
Snow discharge chute	1	M6×16 Screw (5-1)	3		Cross-head Screwdriver
		M6 All-metal hexagon flange lock nut (5-2)	3		Size 10 Wrench
		M8×45 Hexagon flange bolt (5-3)	2		Size 12 Wrench
		M8 All-metal hexagon flange lock nut (5-4)	2		Size 12 Wrench
Discharge adjusting lever	1	R pin (5-5)	1		N/A
Auger control handle	1	Auger control wire assembly			N/A
Self-drive control handle	1	Self-drive control wire assembly			N/A

ASSEMBLY

WHEELS AND SHOES

1. Slide the left wheel (1-1) onto axle (1-2) as the arrow shows (Fig. 1A). Tread pattern should face forward (Fig. 1D). Place axle pin (1-3) into wheel. The axle has a centre hole to attach the wheel to the axle (which connects to the drive train). Once inserted, fold ring around axle to hold in place.
2. Repeat on right side. Tread pattern should face forward (Fig. 1D).

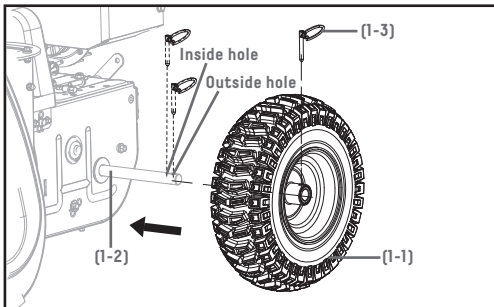

Figure 1A

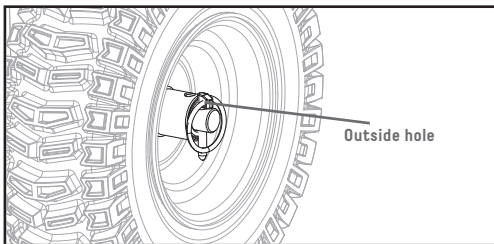

Figure 1B

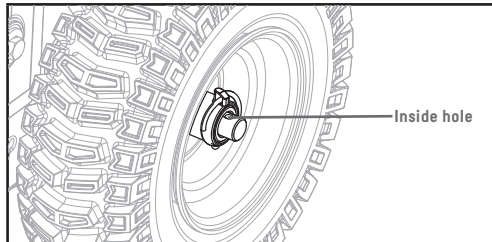

Figure 1C

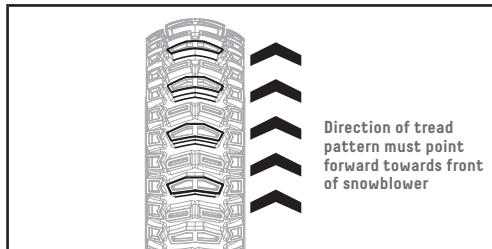

Figure 1D

3. Attach adjustable skid shoes to auger housing. Insert bolts (1-4) through the auger housing then through the shoe (Fig. 2). Tighten nuts (1-5) tightly (Fig. 2). Do not overtighten. The shoe is not reversible. See "Adjusting the Snow Shoes" section.

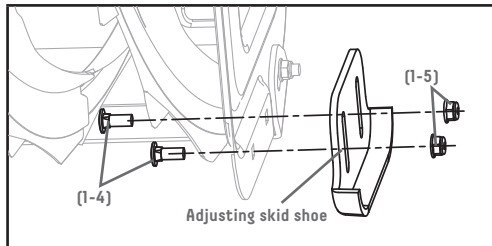

Figure 2

NOTICE:

Only the left axle has two holes (Fig. 1A), and the axle pin can be removed and repositioned. If the wheel is slid further in on the axle with the pin inserted into the outside hole of the axle, the machine will move freely without the engine on (Fig. 1B). If the pin is inserted into the inside hole of the axle, the machine will only move when the drive control is engaged when the engine is on (Fig. 1C).

It is optional to slide one wheel past the pin hole in the axle and to place the locking pin into the axle outside the wheel without locking it into the drive axle. This creates a pivot wheel that allows the operator to more easily turn the snowblower during use by using the "free wheel" as a pivot point. Though this makes turning easier, it decreases drive wheel traction by 50%.

HANDLE

1. Attach the lower handle (2-1) onto the unit body with bolts (2-2, 2-3) and washers (2-4) (Fig. 3). Repeat on the other side.

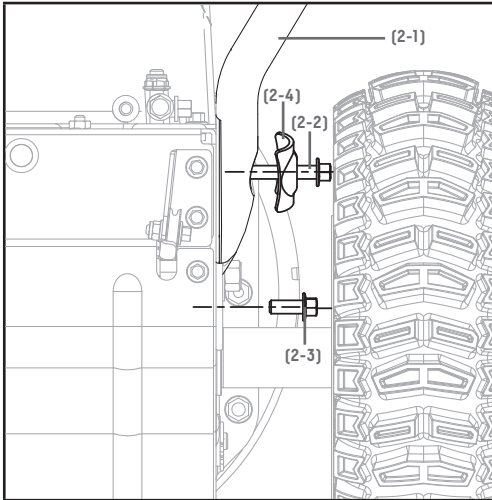

Figure 3

2. Connect the upper handle and lower handle with bolts (2-5), washers (2-6) and locking knobs (2-7) (Fig. 4).

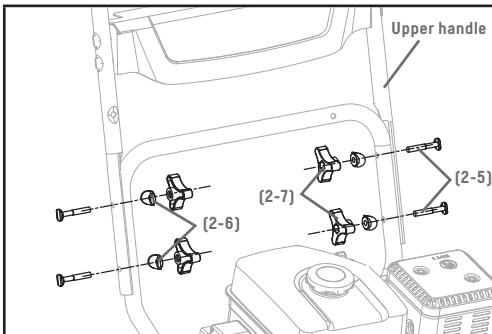

Figure 4

3. Connect discharge chute guide to lower handle with 1 bolt (2-8), and 1 lock nut (2-9) (Fig. 5).

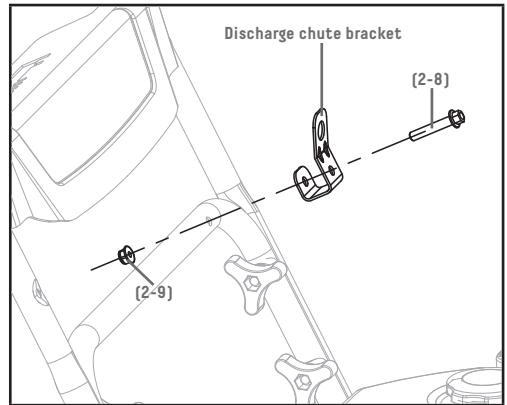

Figure 5

NOTICE:

Discharge chute bracket should be placed forward as shown (for correct placement). Do not overtighten.

SPEED CONTROL CONNECTING LEVER

1. Connect the connecting lever (Fig. 6A) and connecting base with cotter pin (3-1). (Fig. 6B)
2. Connect the connecting lever and speed adjusting handle with cotter pin (3-1) (Fig. 6C).

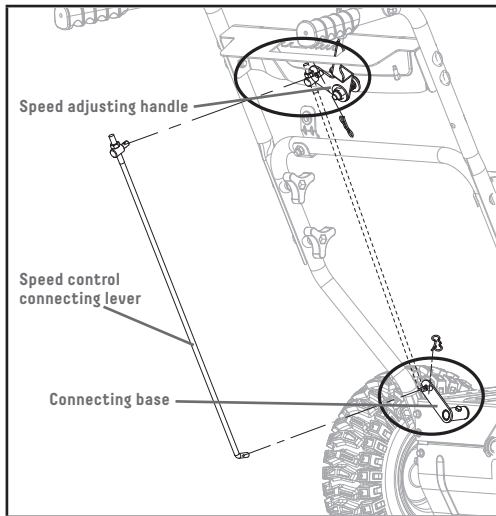

Figure 6A

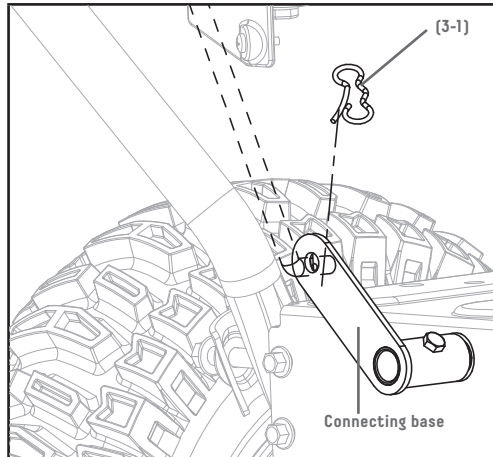

Figure 6B

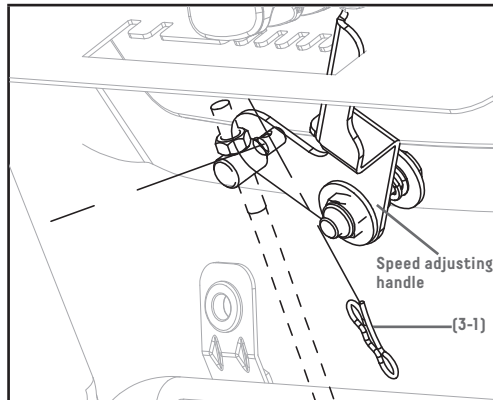

Figure 6C

NOTICE:

In the process of operation, if the auger or drive control handle is too loose, screw the bolt (Fig. 7) of part A to get a natural tension station for the wire.

Check the slack of the tension and adjust accordingly. You want to make sure that the tension on the lower side of the snowblower has 1/4-3/8" (6.4-9.5 mm) of movement. If the slack is greater than 5/8" (16 mm), please adjust. Proper tension is important because you will want your snowblower to move forward properly in heavy snowfalls.

SELF-DRIVE CONTROL WIRE AND AUGER CONTROL WIRE

1. The auger control wire includes part A and part B (Fig. 7).
2. Lift the auger control handle to the upper position (Fig. 7).
3. Hook part A into the auger control handle (Fig. 7).
4. Connect part A and part B of the auger control wire to get a natural tension station for the wire. (Fig. 7)
5. Hook the self-control wire into the self-drive handle in the same way.

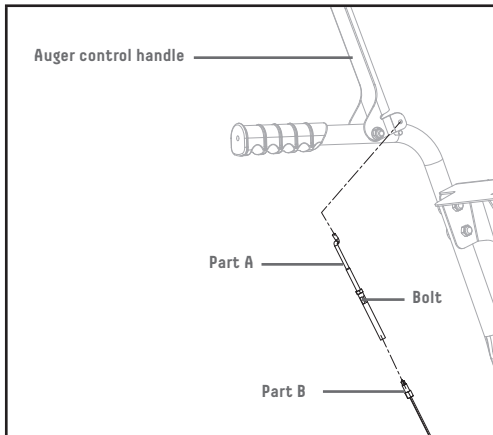

Figure 7

SNOW DISCHARGE SUPPORT

1. Locate the position for assembly (Fig. 8).
2. Remove the bolts (4-1) (Fig. 8) and nuts (4-2) (Fig. 8) from the main body as shown (Fig. 8). Set aside for next step.
3. Align snow discharge support with the main body.
4. Attach the snow discharge support on the main body with bolts (4-1) (Fig. 8).

5. Tighten all nuts (4-2) as shown (Fig. 8). Do not overtighten.

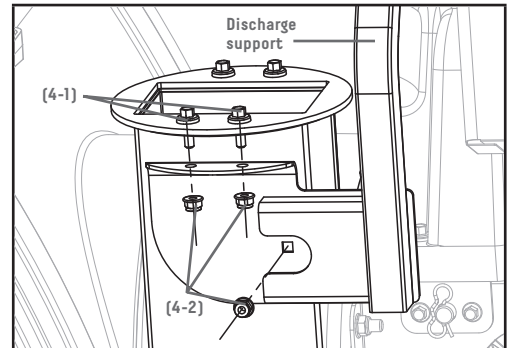

Figure 8

SNOW DISCHARGE CHUTE

1. Remove the bolts (5-1) (Fig. 9A) and nuts (5-2) (Fig. 9A) on the snow discharge chute (Fig. 9A). Hold for later step.
2. Tighten snow discharge chute and the component shown in Fig. 9A using three bolts (5-1) (Fig. 9A) and three nuts (5-2) (Fig. 9A).
3. Put the snow discharge chute on the base of unit's body. Tighten the component on the snow discharge support using bolts (5-3) (Fig. 9B) and nuts (5-4) (Fig. 9B).

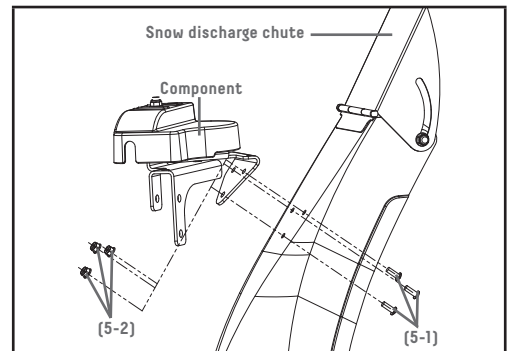

Figure 9A

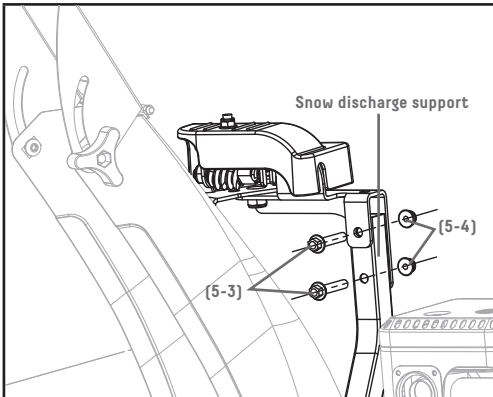

Figure 9B

DISCHARGE CHUTE ROTATION LEVER

1. Insert the lever through the discharge chute bracket on the lower handle, and then into the hole of the gear (Fig. 10A).
2. Adjust the fixed hole of the lever and the gear, and then connected with R pin (5-5). (Fig. 10B)
3. Check the snow discharge chute by turning it fully in both directions. The discharge chute should rotate freely.

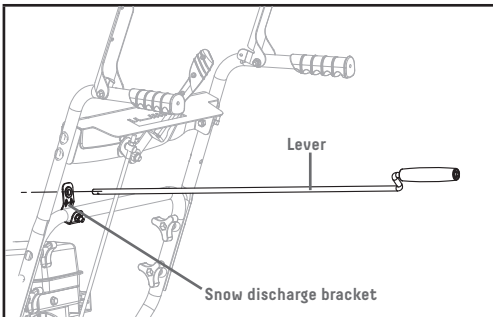

Figure 10A

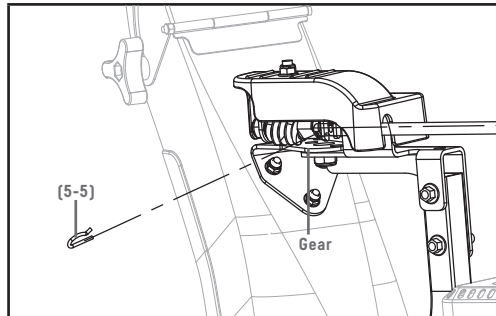

Figure 10B

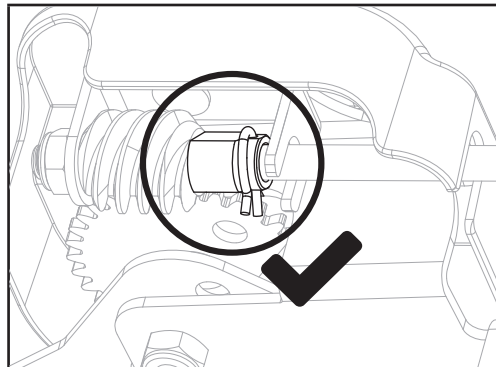

Figure 10C

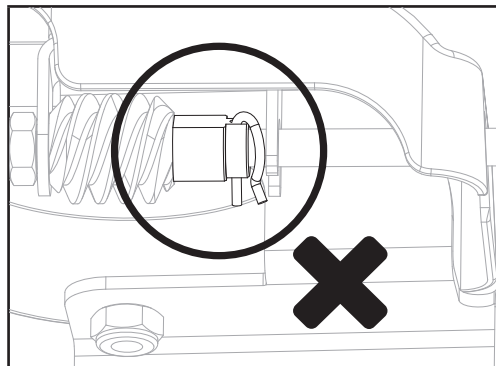

Figure 10D

ASSEMBLY



WARNING

Ensure the R pin (5-5) is positioned as shown in Fig. 10C, not as shown in Fig. 10D.

BEFORE OPERATION**CHECK THE GENERAL CONDITION**

- Look around and underneath the engine for signs of oil or gasoline leaks.
- Remove any excessive dirt or debris, especially around the muffler and recoil starter.
- Look for signs of damage.
- Check that all shields and covers are in place, and all nuts, bolts, and screws are tightened.

CHECK THE ENGINE

1. There is no fuel or oil in the engine. Fill with fuel and add 0W-30 prior to first use.
2. Check the fuel level (see adding fuel section).
3. Check the oil level (see engine oil level check section).
4. See refueling section for more details.

OPERATION**STARTING THE ENGINE**

Read instructions carefully.

1. Make sure the engine safety key is inserted into the key hole (Fig. 11A).
2. Move the fuel valve lever to the on position (Fig. 11A).
3. Move choke lever depending on unit's temperature:
 - a. To start a cold engine, move the choke lever to the choke position (Fig. 11A).
 - b. To start a warm engine, leave the choke lever to the run position (Fig. 11B).
4. Move the throttle lever to full speed to start the engine (Fig. 11B).
5. Use primer control depending on unit's temperature (Fig. 11B):
 - a. To start a cold engine, prime 3-5 times.
 - b. To start a warm engine, do not prime.
6. Stand back and to the right of the unit, pull the starter grip lightly until you feel resistance then pull briskly. Return the starter grip gently (Fig. 11C).

NOTICE:

The engine can be seriously damaged without oil. Always check the oil level before using. The machine must stand on level ground when checking.

**WARNING**

Never start the engine until all the above measures under assembly have been carried out. Never use the snowblower without first reading and understanding the instructions and all the warning and instruction stickers on the machine. Always use protective goggles or a visor during use, maintenance and service.

7. Alternatively for electric start, plug in the supplied electrical cord into the starter. Press the electric start button and make sure that the mains supply voltage is 120 V~ 60 Hz (Fig. 11D).
8. When the engine starts, move the choke to run position (Fig. 11B).

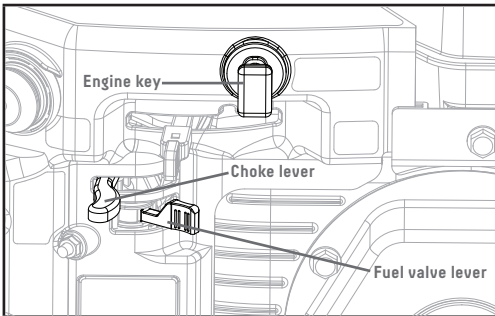

Figure 11A

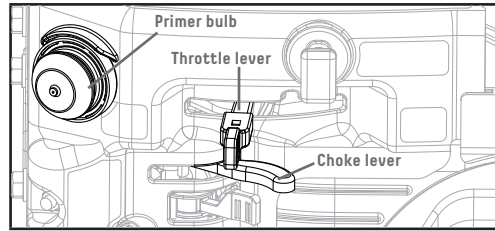

Figure 11B

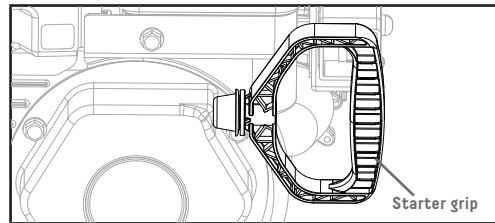

Figure 11C

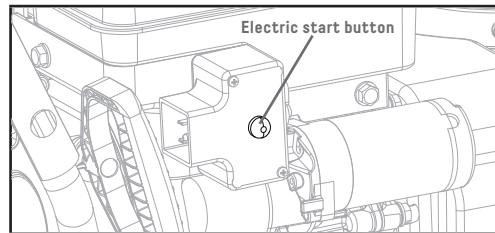

Figure 11D



WARNING

Gasoline is highly flammable.

Store fuel in containers specifically designed for this purpose. Refuel outdoors only, before starting the engine, and do not smoke while refueling or handling fuel. Never remove the cap of the fuel tank or add gasoline while the engine is running or when the engine is hot. If gasoline is spilled, do not attempt to start the engine but move the machine away from the area of spillage and avoid creating any source of ignition until gasoline vapours have dissipated. Replace all fuel tanks and container caps securely. Before tipping the snowblower to maintain the blade or drain oil, remove fuel from tank.

WARNING

Never fill fuel tank indoors, with engine running, or until the engine has been allowed to cool for at least 15 minutes after running.

CAUTION

To prevent damaging the electric starter, do run it not more than 10 times at intervals of 5 seconds on, then 5 seconds off. If the engine does not start after this series of attempts, allow the starter to cool for at least 40 minutes before trying to start it again. If the engine still does not start, take the engine to an authorized service centre for service. Once started, disconnect the plug from the power supply and the starter.









STOPPING THE ENGINE

To stop the engine in an emergency, simply remove the engine key.

Under normal conditions move the fuel valve lever to the OFF.

OPERATING THE MACHINE

CONTROL LEVERS

  	<p>Self-drive control handle. Located on the right side handle (Fig. 12).</p> <p>When the snowblower has been put into gear, pushing this lever towards the handle engages the wheels.</p> <p>Releasing the self-drive control handle causes the machine to stop moving.</p>
  	<p>Auger control handle. Located on the left side handle (Fig. 12).</p> <p>Pushing this lever towards the handle causes the auger and impeller to activate.</p> <p>Releasing the auger control handle causes the auger to stop moving.</p>

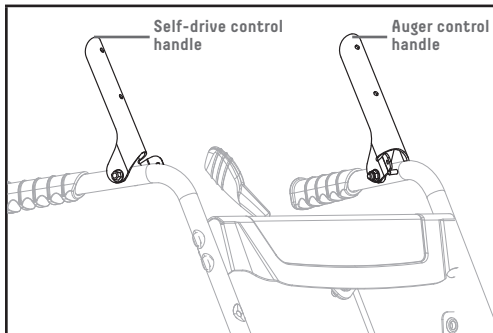

Figure 12

DRIVE SYSTEM

Your snowblower has 6 forward speeds and 2 reverse to regulate forward and backward motion (Fig. 13).

The speed-adjusting system has forward speeds ranging from slowest position 1 to fastest position 6. In reverse, R1 is the slowest speed and R2 the fastest.

Adjusting the self-propelled drive system:

1. Release the self-drive control handle to bring the snowblower to a stop.
2. Move the speed-control lever to the gear (either forward or reverse) that you require (Fig. 13).
3. Press the self-drive control handle to engage the drive system.

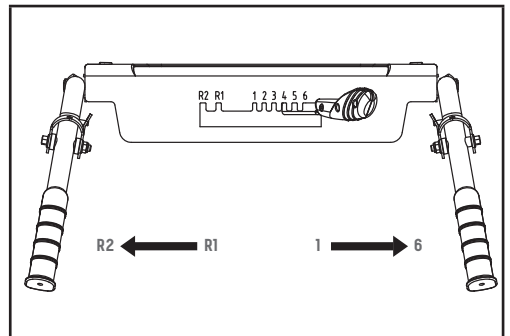

Figure 13





WARNING

Watch out for rotating auger. Keep hands, feet, hair and loose clothing away from any moving parts on the machine.



ADJUSTING THE SNOW DISCHARGE DIRECTION AND HEIGHT

Change discharge direction:

	Turn the lever counter-clockwise – the snow discharge guide turns to the left.
	Turn the lever clockwise – the snow discharge guide turns to the right.

Change discharge height:

1. Loosen the locking knob to adjust the snow discharge deflector to a suitable height (Fig. 14).
2. Adjust the snow discharge deflector from 0 – 60°.
3. Tighten the locking knob.

	Low - shorter ejection distance
	High - longer ejection distance

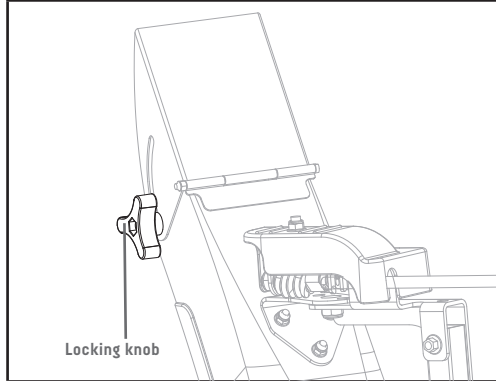

Figure 14



WARNING

If snow clogs the discharge chute do not try to remove it before:

- Releasing the auger control handle.
- Stopping the engine.
- Disconnecting the cable from the spark plug.

Do not put your hand inside the chute or auger. Use the chute clearing tool included with your snowblower.

ADJUSTING THE SNOW SHOES

Set the height of the auger housing above the ground using the shoes.

Adjust the shoes to suit the ground conditions:

- On flat ground, e.g. asphalt, the shoes should be adjusted to about 5 mm (the distance from the auger to the ground) (Fig. 15A).
- On uneven ground, e.g. gravel paths, the shoes should be adjusted to about 30 mm (the distance from the auger to the ground) (Fig. 15B).

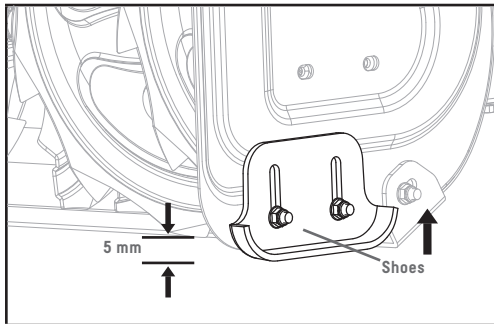

Figure 15A

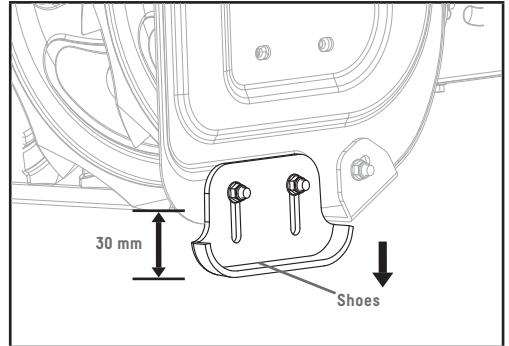

Figure 15B

TO ADJUST THE SHOES

1. Loosen the nuts.
2. Move the shoes upward or downward to adjust height.
3. Tighten the nuts.



CAUTION

Always adjust the shoes so that gravel and stones are not fed into the snowblower. There is a risk for personal injury if these are thrown out at high speed.

Ensure the shoes are adjusted the same on both sides.

CAUTION

Do not at any time make any adjustment to machine without first stopping the engine and disconnecting the spark plug wire.

CAUTION

Before changing height, stop engine and disconnect spark plug cable.

AFTER USE

1. Check for loose or damaged parts. If required, change damaged parts.
2. Tighten loose screws and nuts.
3. Brush all the snow from the machine.
4. Move all the controls backwards and forwards a few times.
5. Put the choke in position.
6. Disconnect the starting cable from the spark plug.

SERVICING

SAFETY PRECAUTIONS

Make sure the engine is off before you begin any maintenance or repair. This will eliminate several potential hazards:

- Carbon monoxide poisoning from engine exhaust — never run the machine indoors. The exhaust fumes contain carbon monoxide, a very toxic gas.
- Burns from hot parts — let the engine cool for 30 minutes before touching hot parts.
- Injury from moving parts — read the instructions before you begin, and make sure you have the tools and skills required.

To reduce the possibility of fire or explosion, be careful when working around gasoline. Use only a nonflammable solvent, not gasoline, to clean parts. Keep cigarettes, sparks and flames away from all fuel-related parts.

OPERATION

MAINTENANCE



CAUTION

Do not cover the machine while the engine and silencer are still warm.

MAINTENANCE

REGULAR SERVICE PERIODS

Perform at every indicated month or operating hour interval, whichever comes first.

Item	Service	Each Use	Every month or 20 hrs.	Every 3 months or 50 hrs	Every 6 months or 100 hrs.	Every year or 150 hrs.	
Engine Oil	Check level	<input type="checkbox"/>					
	Change		<input type="checkbox"/>		<input type="checkbox"/>		
Spark Plug	Check-Clean				<input type="checkbox"/>		
	Replace					<input type="checkbox"/>	
Spark Arrester (optional parts)	Clean				<input type="checkbox"/>		
Idle Speed	Check-adjust					<input type="checkbox"/> (1)	
Valve Clearance	Check-adjust					<input type="checkbox"/> (1)	
Fuel Tank and Strainer	Clean					<input type="checkbox"/> (1)	
Fuel Line	Check	Every 2 years (replace if necessary) (1)					

(1) These items should be serviced by your servicing dealer unless you have the proper tools and are mechanically proficient. Refer to manual for service procedures.

REFUELING

Use unleaded gasoline to produce fewer engine and spark plug deposits and extend exhaust system life.

ADDING FUEL

1. Remove the fuel tank cap (Fig. 16).
2. Add fuel to the bottom of the fuel level limit in the neck of the fuel tank. Do not overfill. Wipe up spilled fuel before starting the snowblower.

Fuel tank capacity: 0.9 gal (3.4 L).

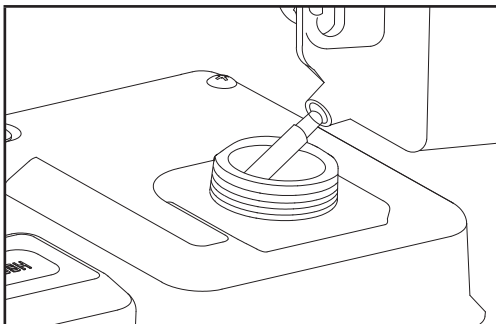

Figure 16

ENGINE OIL LEVEL CHECK

1. Check the oil with engine stopped and level.
2. Remove the oil cap/dipstick and wipe it clean (Fig. 17A).

3. Insert the oil cap/dipstick into the oil filler neck but do not screw it in, then remove it to check the oil level (Fig. 17B).
4. If the oil level is near or below the lower limit mark on the dipstick, remove the oil cap/dipstick, and fill with the recommended oil to the upper limit mark. Do not overfill (Fig. 17B).
5. Reinstall the oil cap/dipstick.

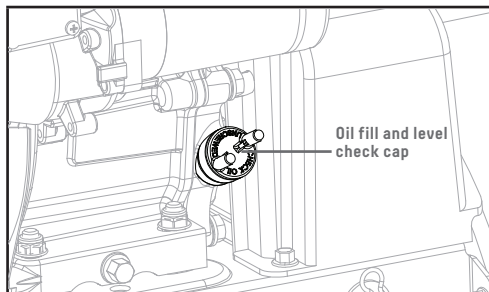

Figure 17A

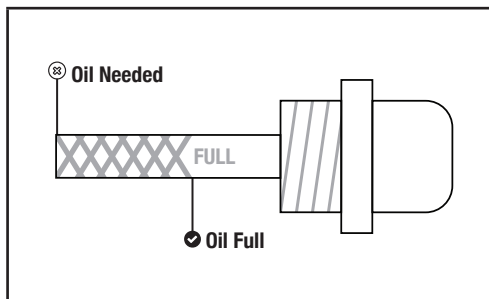

Figure 17B



WARNING

Gasoline is highly flammable and explosive, and you can be burned or seriously injured when refueling.

- Stop engine and keep heat, sparks, and flame away.
- Refuel only outdoors.
- Gasoline is poisonous, be careful not to touch or breathe in the vapour.

OIL CHANGE

Drain the engine oil when the engine is warm. Warm oil drains quickly and completely.

1. Turn the fuel valve lever to the OFF position to reduce the possibility of fuel spillage.
2. Place a suitable container below the snowblower to catch the used oil.
3. Remove the drain bolt and drain the oil into the container by slightly tipping the engine toward the oil cap/dipstick (Fig. 18).
4. With the engine in a level position, fill to the upper limit mark on the dipstick with the recommended oil (0W-30).
5. Reinstall the oil cap/dipstick securely.

Capacity of engine oil: 0.6 L

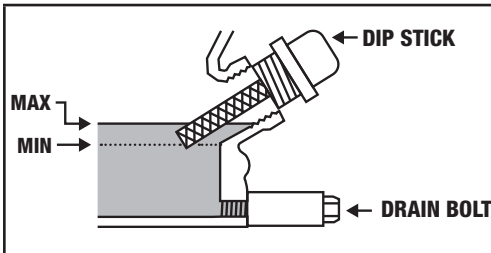

Figure 18

REPLACING SHEAR PINS

The auger housing is shown as Fig. 19A.

The augers are secured to the spiral shaft with shear pins (a) and clips (b). If the auger should strike a foreign object or ice jam, the snowblower is designed so that the lock pins may shear. If the augers will not turn, check to see if the lock pins have sheared (Fig. 19B). Replace shear pin(s) and clip(s) as necessary.

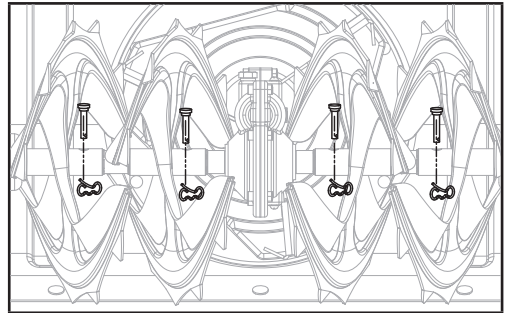

Figure 19A

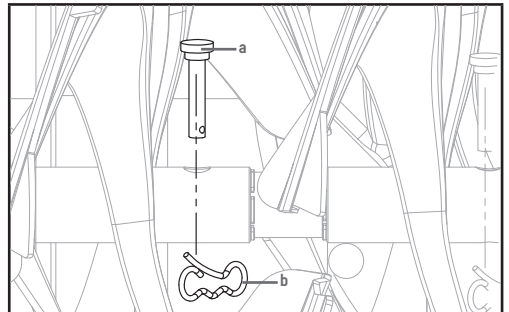

Figure 19B

**WARNING**

- Running the engine with a low oil level can cause engine damage.
- Engine oil is poisonous, be careful not to touch it.
- With engine off but still warm, disconnect the spark plug wire and keep it away from the spark plug.
- We suggest you take used oil in a sealed container to your local recycling centre or service station for reclamation. Do not throw it in the trash, pour it on the ground, or down a drain.

ADJUSTING SELF-DRIVE CONTROL HANDLE CABLE

Check the slack of the tension and adjust accordingly. Make sure that the tension on the self-drive cable is adjusted so it has between 1/4-3/8" (6.4-9.5 mm) of movement. This movement can be acquired by measuring the distance the engagement paddle moves from its starting position and the point it becomes taut and starts to move the transmission adjustment lever. If the slack is greater than 5/8" (16 mm), please adjust. Proper tension is important because you will want your snowblower to move forward properly in heavy snowfalls.

While operating the snowblower, if the self-drive control lever is too loose, tighten the nut counter-clockwise while at the same time rotating the bolt upward to reach the position of the nut (Fig. 20).

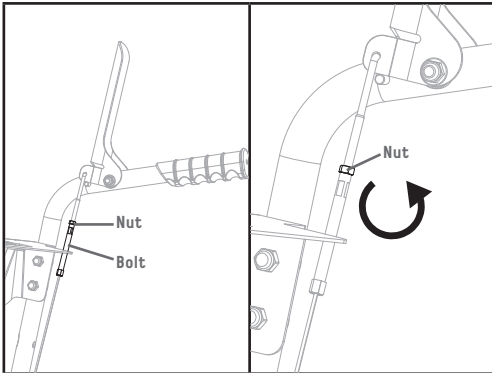

Figure 20

ADJUSTING AUGER CONTROL CABLE

Check the slack of the tension and adjust accordingly. Make sure that the tension on the auger control cable is adjusted so it has between 1/4-3/8" (6.4-9.5 mm) of movement. This movement can be acquired by measuring the distance the engagement paddle moves from its starting position and the point it becomes taut and starts to engage the auger. If the slack is greater than 5/8" (16 mm), please adjust. Proper tension is important because you will want your snowblower to maximize belt life in heavy snowfalls.

While operating the snowblower, if the auger control lever is too loose, tighten the nut counter-clockwise while at the same time rotating the bolt upward to reach the position of the nut (Fig. 21).

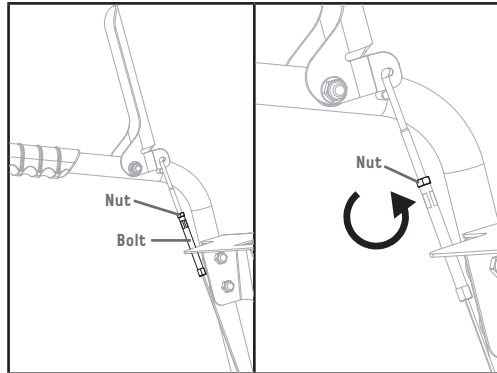

Figure 21



WARNING

No service must be carried out before:
The engine has stopped.
The cable has been disconnected from the spark plug.

REPLACE TRACTION DRIVE BELT

Tools required:

- Size 10 wrench.
- Size 12 wrench.
- Size 13 wrench (not included).

To remove and replace your snowblower's drive belt, proceed as follows:

1. Pull out the R pin (1) (Fig. 22B).
2. Remove the lever (2) from the discharge chute bracket (Fig. 22C).
3. Unscrew the bolt of auger control wire (3) (Fig. 22C).
4. Remove the plastic belt cover (4) on the front of the engine by removing two M6 × 16 bolts (5) (Fig. 22D).

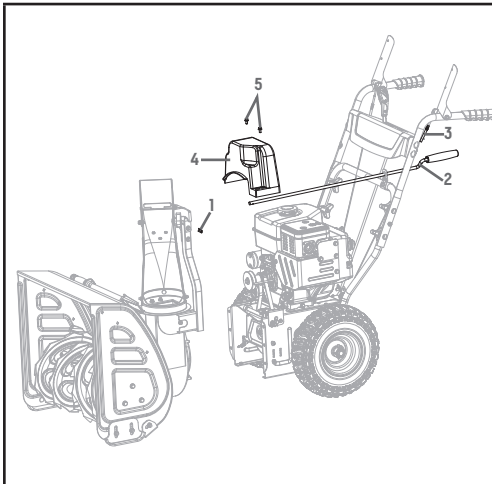

Figure 22A

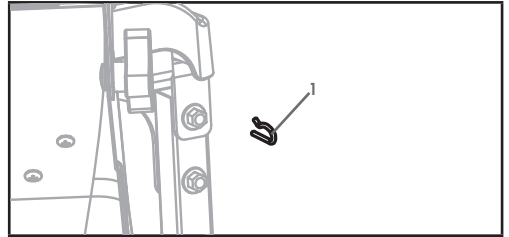

Figure 22B

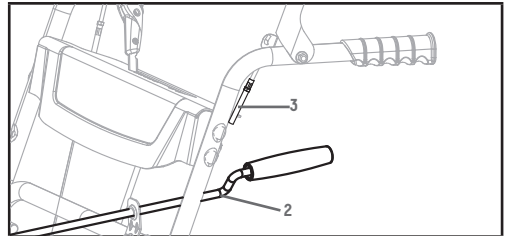

Figure 22C

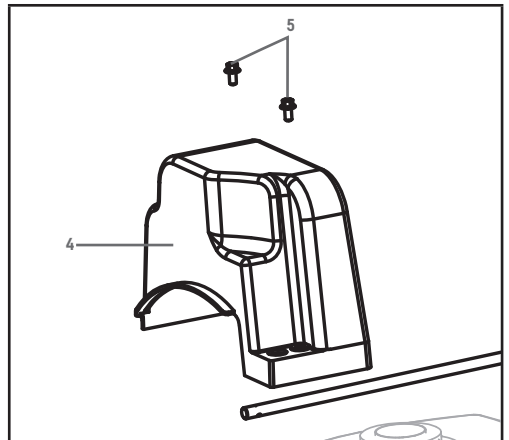

Figure 22D

NOTICE:

To prevent spillage, remove all fuel from the tank by running the engine until it stops. Do not attempt to pour fuel from the engine. Disconnect the spark plug before performing any service.

5. Loosen the belt lever 20 mm bolt (6) (Fig. 23).
6. Unscrew six M8 nuts to separate the auger housing from the base (7) (Fig. 23).

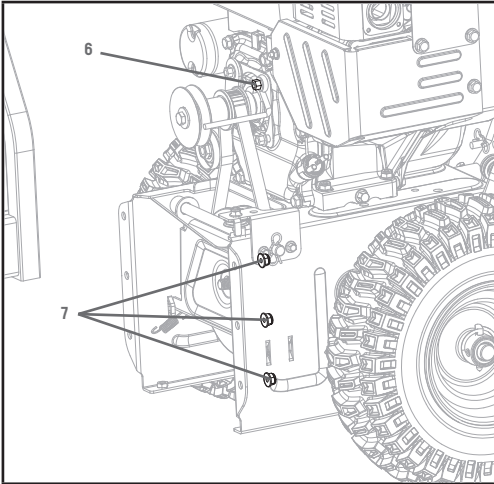

Figure 23

7. Unscrew the bolt on the belt support seat (8) (Fig. 24).
8. Slip the drive belt off the pulley (9). Remove and replace the belt in reverse order ensuring that the new belt is below the spring loaded idler pulley as shown in figure 24.

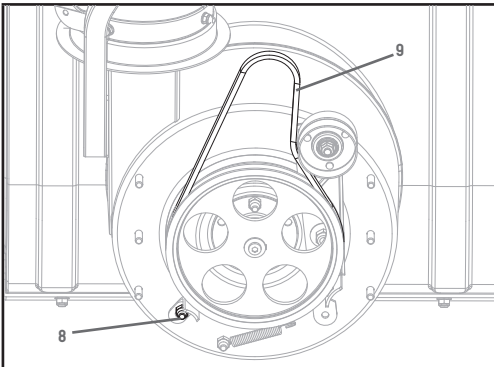

Figure 24

9. Once the belt is replaced, tighten the 20 mm bolt (6), ensuring the clearance between the belt lever (10) and the pulley (11) is 5/16" (8 mm) (Fig. 25).

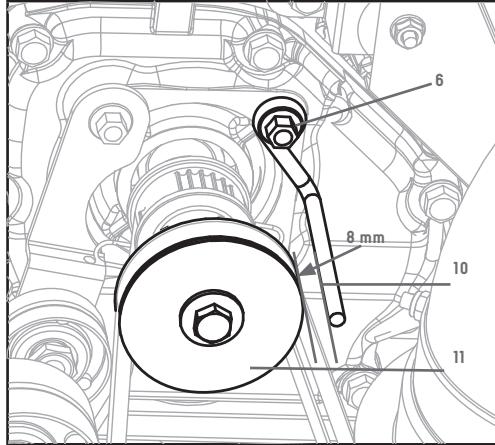

Figure 25

10. Install the plastic belt cover (4) on the front of the engine using two M6 × 16 bolts (5) set aside from an earlier step. Tighten until snug. Do not overtighten or you risk damaging the plastic belt cover (Fig. 26).
11. Perform a drive test to confirm everything is in working order.

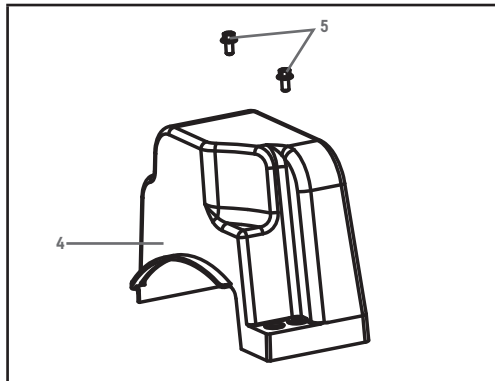

Figure 26

REPAIR OR REPLACE FRICTION DISK

Tools required:

- 10 size wrench.
- 17 size wrench (not included).

To remove and replace your snowblower's friction disc, proceed as follows:

1. Carefully pivot the snowblower up and forward so that it rests on the auger housing. Place a piece of cardboard or moving blanket on the ground before tipping forward. Make sure all fluids are removed and spark plug is disconnected.
2. Remove the base frame cover (1) from the underside of the snowblower by removing the six M6 × 16 screws which secure it (Fig 27A/B).
3. Remove the right wheel (2) by removing the axle pin on it (Fig. 27C).

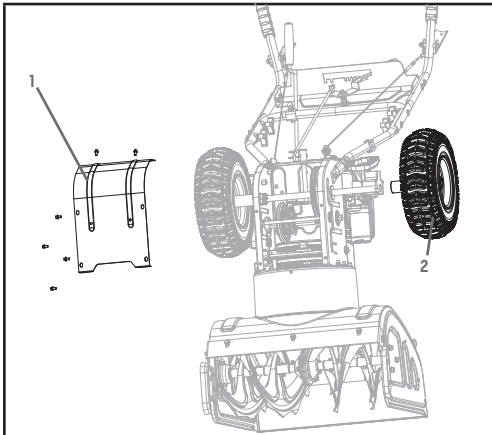

Figure 27A

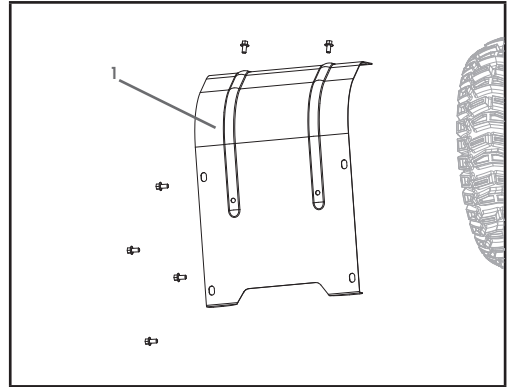

Figure 27B

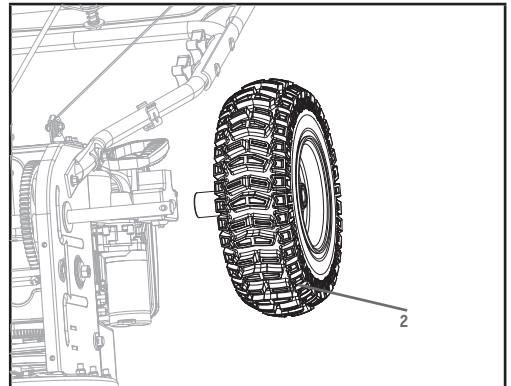

Figure 27C

NOTICE:

If the snowblower fails to drive with the drive control engaged, and performing the drive control cable adjustment fails to correct the problem, the friction disc may need to be replaced.

To prevent spillage, remove all fuel from the tank by running the engine until it stops. Do not attempt to pour fuel from the engine. Disconnect the spark plug before performing any service.

- Carefully remove the M10 hex nut (3) which secures the hex shaft (4) to the snowblower frame and lightly tap the shaft's end to dislodge the ball bearing from the right side of the frame (Fig. 28).

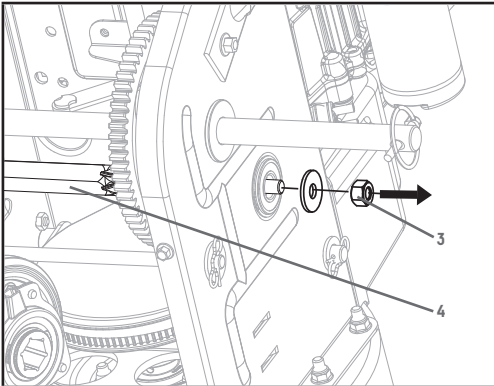

Figure 28

- Carefully position the hex shaft downward and to the left before carefully sliding the friction disc assembly (5) off the shaft (Fig. 29).

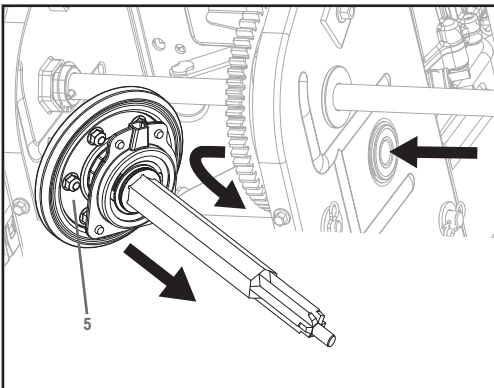

Figure 29

- Unscrew the six M6 × 16 bolts (6) of the friction disc assembly to discard the worn friction wheel rubber ring (7) and replace with a new one (Fig. 30).

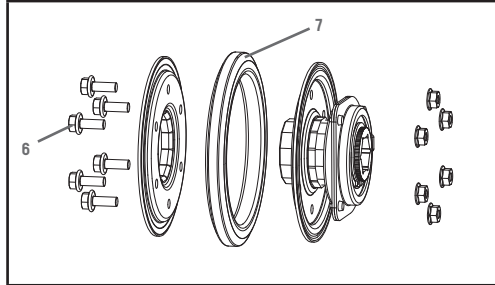

Figure 30

- Follow the previous steps in reverse order to reassemble the parts.
- Perform a drive test to confirm everything is in working order.

LUBRICATION

Lubricate the linkage every 10 hours of use and before long-term storage. Use 0W-30 oil.

No parts inside the gearbox are to be lubricated. All bearings and bushings are permanently lubricated and require no maintenance.

Lubricating these parts will only result in the grease getting on to the friction wheel and disc drive plate, which could damage the rubber clad friction wheel.

STORAGE

Never store the machine with gasoline in the fuel tank in a confined area with bad ventilation. Gasoline fumes could reach open flames, sparks and cigarettes etc.

To avoid the engine freezing and problems starting the engine, leave the engine running for 5-10 minutes after your work has been completed. This will ensure all moisture will disappear that would otherwise cause starting problems.

If the machine is to be stored for a longer period than 30 days, the following procedures are recommended.

1. Start the engine and let it run until it stops due to lack of fuel.
2. Change the engine oil if it has not been done for 3 months.
3. Remove the spark plug and empty a little engine oil (about 30 mL) in the hole. Crank the engine a couple of times. Replace the spark plug.
4. Clean the whole machine thoroughly.
5. Lubricate all the parts as shown in LUBRICATION section above.
6. Inspect the machine for damage, and repair if necessary.
7. Touch up any paint damage.
8. Apply rust protection to the metal surfaces.
9. Store the machine indoors if possible.

TRANSPORTING

If the engine has been running, allow it to cool for at least 15 minutes before loading the machine on the transport vehicle. A hot engine and exhaust system can burn you and can ignite some materials.

Keep the engine level when transporting to reduce the possibility of fuel leakage. Move the fuel valve lever to the OFF position.

SPECIFICATIONS**SNOWBLOWER SPECIFICATIONS**

- Stages..... 2
- Speed Control..... 6 forward/2 reverse
- Auger Diameter..... 12" (30 cm)
- Clearing Width 22" (56 cm)
- Clearing Height..... 21" (53 cm)
- Wheel Diameter..... 13" (33 cm)

ENGINE SPECIFICATIONS

- Brand..... Champion Power Equipment
- Displacement 224 cc
- Engine Model YF172ST
- Start Type..... Electric, Recoil
- Clearing Width (in.) 22" (56 cm)
- Clearing Height (in.) 21" (53 cm)

OIL SPECIFICATIONS

- Oil Capacity 20 oz (0.6 L)
- Oil Type 0W-30

FUEL SPECIFICATIONS

- Fuel Capacity 0.9 gal (3.4 L)

PARTS LIST DIAGRAM

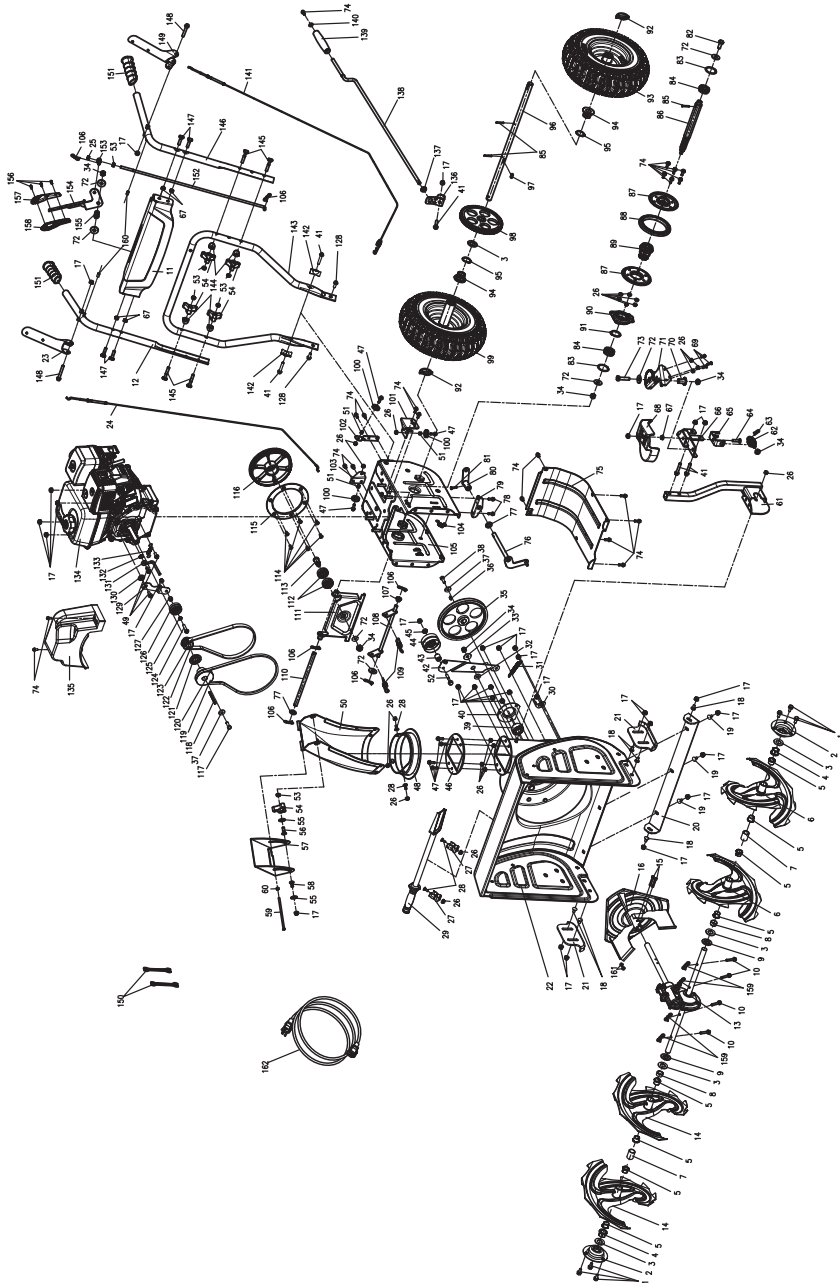

PARTS LIST

#	Part Number	Description	Qty.
1	30913070165000	Hexagon Flange Bolt, M8 x 16, Blue Zinc	6
2	23052000115000A	Bearing Support, 2, White Zinc	2
3	23092000055000A	Flat Washer, Ø20 x Ø37 x 2, Blue Zinc	5
4	23053000035000A	Bearing Sheath, Auger	2
5	23051000130001B	T Type Bearing Sheath, Auger, Black	8
6	23055000110026N	Left Auger Assembly, Cool Gray 9 C	2
7	23051000120001B	Long Bearing Sheath, Auger, Ø19.4 x Ø24.2 x 25.3, Black	2
8	23051000110001B	Short Bearing Sheath, Auger, Ø19.4 x Ø24.2 x 16, Black	2
9	22627000125000A	Wool Felt Washer, Ø40 x Ø20 x 3, White	2
10	23093000025000A	Shear Pin, Ø6 x 35.5, Blue Zinc	4+4
11	23065000200026N	Gear Panel Assembly, Cool Gray 9 C	1
12	23063000570001A	Right Upper Handle Assembly, Black	1
13	23029000145000A	Worm Gear Box Assembly, 22"	1
14	23055000100026N	Right Auger Assembly, Cool Gray 9 C	2
15	30223010055000	Hexagon Bolt, M6 x 40, Black Zinc	2
16	23055000160026N	Fan Impeller Assembly, Cool Gray 9C	1
17	30323060035000	Flange Locking Nut, M8, All Metal Hexagon, Blue Zinc	33
18	30913090025000	Half-Round Head Square Neck Bolt, M8 x 20, Blue Zinc	6
19	30913090015000	Half-Round Head Square Neck Bolt, M8 x 16, Blue Zinc	3
20	23032000220001N	Snow Shovel Plate, 22 inch, Black	1
21	23032000230001N	Sled, Δ5, 159.7 x 85, Black	2

#	Part Number	Description	Qty.
22	23035000100209N	Big Housing Assembly, Green 7733C	1
23	23062000160001B	Right Trigger, Black	1
24	23068000235000A	Self-Driving Assembly, 970 mm	1
25	30313090025000	Hexagon Locking Nut, M8, White Zinc	1
26	30323060015000	Flange Locking Nut, M6, All Metal Hexagon, Blue White Zinc	22
27	23092000075000A	Bracket, Snow Removal, Δ1.2, 39.2 x 30.4 x 13, White Zinc	2
28	30913090035000	Half-Round Head Square Neck Bolt, M6 x 16, Blue White Zinc	4
29	23002000135000	Snow Removal (Shovel) Assembly, Black	1
30	23032000135000A	Belt Support, 2,40 x 38 x 20.5, White Zinc	1
31	23038000105000A	Tension Spring, 65 mm, Big Tension Wheel, White Zinc	1
32	23034000315000B	Bushing, Ø25 x Ø10.2 x 5.8, Large Tension Board	1
33	23092000025000A	Spherical Washer, Ø10 x Ø28.7 x 2.3, Black	1
34	23093000125000A	Hexagon Locking Nut, M10, Blue White Zinc	6
35	23034000135000B	Big Triangle Pulley, Ø200 x 15.7, Black	1
36	23093000165000A	Flat Washer, 6 x 6 x 15, Black	1
37	23032000335000A	Thickened Big Washer, Ø8.2 x Ø30 x 3.7, White Zinc	2
38	30913040115000	Hexagon Bolt, M8 x 25, Blue White	1
39	30693010015000	Spherical Bearing	1
40	23052000125000B	Pressing Plate, Bearing, Δ2, Ø95 x 8.5, White Zinc	1
41	30913070065000	Hexagon Flange Bolt, M8 x 45	5
42	23032000255000B	Large Tension Board Δ3	1

SPECIFICATIONS

model no. 060-3732-6 | contact us 1-844-428-7277

SPECIFICATIONS

#	Part Number	Description	Qty.
43	23034000345000A	Sheath (Thick), Large Tension Wheel, Ø20 × Ø8 × 16.5	1
44	23032000105000C	Large Tension Wheel Assembly	1
45	23034000325000A	Sheath (Thin), Large Tension Wheel, Ø20 × Ø8 × 5.5	1
46	23071000210001C	Steering Positioning Plate, Ø158.5 × 4, Black	1
47	30913070105000	Hexagon Flange Bolt, M6 × 20, Blue White Zinc	7
48	23075000165001N	Steering Positioning Block Assembly, Ø195 × 5l,	1
49	23093000175000A	Hexagon Flange Bolt, 5/16" (24UNF-2A)	3
50	23075000120001N	Snow Bucket Assembly, 388 × 295.5 × 164.7, Black	1
51	23033000185000A	Roller Sleeve, White Zinc	3
52	30913040145000	Hexagon Bolt, M8 × 40, Blue Zinc	1
53	30313060025000	Hexagon Nut, M8, Blue White Zinc	6
54	21061000400001A	Rotating Knob, Black	5
55	23071000140001B	Snow Bucket Washer, Black	2
56	30913090045000	Half-Round Head Square Neck Bolt, M8 × 25, Blue White Zinc	1
57	23075000100001N	Small Snow Bucket Assembly, Black	1
58	23099000045000A	Flat Head Inner Hexagon Bolt, M8 × 17, White Zinc	1
59	23093000155000A	Hinge Pin, Ø5, White Zinc	1
60	30313090055000	Hexagon Locking Nut, M5, Blue White Zinc	1
61	23075000130001N	Bracket Assembly, 178 × 92.5 × 392, Black	1
62	23073000115000A	Steering Worm, Ø29.2 × 61, White Zinc	1
63	23093000135000A	R Pin, Ø2.5 × 26.3 × 12.3, White Zinc	1
64	30933010035000	Half-Round Head Square Neck Bolt, M8 × 30, Blue White Zinc	1
65	23073000135000A	Worm Bracket, 64 × 40 × 24, Black	1

#	Part Number	Description	Qty.
66	23062000415000C	Connection Plate, 140 × 98.5 × 148	1
67	30333040045000	Serrated Anti-Slip And Anti-Loose Hexagon Flange Nut, M8, Blue White Zinc	5
68	23041000330001A	Worm Protection Cover, Pp+Gf30, Black	1
69	30213020045000	Machine Teeth Screw, M6 × 16, White Zinc	3
70	23024000195000A	Spacer Bushing, Worm Wheel Plate, Ø29 × Ø25.6	1
71	23072000115000B	Worm Wheel Plate, T=3.2, 102.5 × 82.9 × 86.2, Black	1
72	30512050045000	Big Washer, Ø10, Blue White Zinc	7
73	30913030045000	Half-Thread Hexagon Bolt, M10 × 45, White Zinc	1
74	30913070015000	Hexagon Flange Bolt, M6 × 16, White Zinc	21
75	23032000160001N	Big Bottom Plate, Black	1
76	23032000195000A	Gear Shift Fork Assembly, Ø13, White Zinc	1
77	23092000045000A	Flat Washer, Ø14 × Ø25 × 2.5, Blue White Zinc	2
78	30913070055000	Hexagon Flange Bolt, M6 × 12, Blue White Zinc	2
79	23032000185000A	Shifting Fork Plate, T=1.5, 95 × 22 × 26.5, White Zinc	1
80	23062000255000A	Gear Link Plate Assembly, Black	1
81	30913040135000	Hexagon Bolt, M5 × 20, Black Zinc	1
82	30913040065000	Hexagon Bolt, M10 × 20, Blue White Zinc	1
83	23092000065000A	Shaft Ring, Ø38 × Ø43.6 × 1, Black	2
84	23013000025000A	Bearing, 6203Z, 1.6 × 1	2
85	30823060015000	Elastic Column Pin, 4 × 30, Black	3
86	23033000105000A	Wheeled Six Party Shaft, Ø17 × 22 × 253, White Zinc	1
87	23032000285000B	Friction Wheel Clamp, Ø117.6, White Zinc	2
88	23036000105000A	Friction Wheel Rubber Ring, Ø127 × 12.4	1

#	Part Number	Description	Qty.
89	23034000285000B	Wheeled Six Party Sleeve, Ø52 x 52.9	1
90	23032000215000A	Shifting Fork Riveting, White Zinc	1
91	30423010065000	A Type External Circlips, Ø35, Black	1
92	23093000145000A	O Type Elastic Pin, Ø6.2 x 40, Blue White Zinc	2
93	2301900005A	Left Wheel Assembly, 13 x 4.1 inch, Cool Gray 9C	1
94	23034000255000B	Hexagon Angle Bushing, Ø19 x Ø45 x 25.3	2
95	30423010075000	A Type External Circlips, Ø30, Black	2
96	23013000115000B	Wheel Shaft, Ø19, Black	1
97	31013010045000	Flat Key, 6 x 6 x 18, Black	1
98	23034000105000A	Transmission Gear	1
99	2301900006A	Right Wheel Assembly, 13 in. x 4.1 inch, Black	1
100	23061000130001B	Wire Roller, Black	3
101	23035000125000B	Front Wire Support Seat Assembly, White Zinc	1
102	23032000175000B	Clutch Wire Support Seat, White Zinc	1
103	23062000145000B	Self Driving Wire Support Seat, White Zinc	1
104	23038000125000C	Extension Spring, Ø8.5 x 44.9, White Zinc	1
105	23035000110209N	Housing Assembly, Green 7733C	1
106	22698000065000A	B Pin, White Zinc, Ø2 x 38 x 18	6
107	23034000355000A	Rocker Arm Spacer Bushing, Ø10.1 x Ø20 x 10	1
108	23032000275000A	Rocker Arm, White Zinc	1
109	23068000125000A	Self-Driving Extension Spring, Ø2.1 x Ø15 x 86.5, White Zinc	2
110	23033000335000A	Bracket Shaft, Ø12.5 x 245	1
111	23035000140001B	Friction Disc Bracket Assembly, Black	1
112	30613010075000	Deep Groove Ball Bearing, 6203RS	2
113	23033000115000B	Large Synchronous Pulley Shaft, Ø17 x Ø20 x 39.3, Black	1

#	Part Number	Description	Qty.
114	30213010035000	Cross Recessed Countersunk Head Screw, M6 x 12, Blue White	6
115	23034000195000A	Large Synchronous Pulley Side Plate, Ø169.5	1
116	23034000185000C	Large Synchronous Pulley, Ø170	1
117	30913040085000	Hexagon Bolt, M8 x 35, Blue White Zinc	1
118	23013000015000A	Flat Key, 4.78 x 4.78 x 70, Black	1
119	23034000145000B	Small Triangle Belt, Ø19 x Ø72.5 x 49.5, Black	1
120	23096000175000A	Triangle Belt, 4LXP875	1
121	23034000205000B	Small Synchronous Bushing, Ø46 x 4	1
122	23034000165000B	Small Synchronous Belt, Ø47 x 31.9	1
123	23096000165000A	Synchronous Belt, 740 x 5 mm	1
124	30913070195000	Hexagon Flange Bolt, M8 x 35, Blue White Zinc	1
125	23034000265000A	Shaft Sheath, Small Tension Pulley, Ø8 x Ø15 x 6.1	1
126	23032000115000A	Small Tension Pulley Assembly, Ø45 x 19.4	1
127	23034000275000B	Shaft Sheath, Small Tension Pulley, Ø8 x Ø15 x 11.5	1
128	30913070185000	Hexagon Flange Bolt, M8 x 20, Blue White Zinc	2
129	23032000265000A	Small Tensioning Plate, 3, White Zinc	1
130	23034000295000B	Small Tensioning Plate Cushion, Ø8.2 x Ø25 x 6.3	1
131	23033000225000B	Belt Stop, Ø6, White Zinc	1
132	23092000035000A	External Teeth Locking Washer, Ø8, Black Zinc	1
133	23038000135000A	Small Tension Pulley Spring, Ø1.5 x Ø10.5 x 69.3, White Zinc	1
134	2030100002A	Engine, YF172ST, 224 cc	1
135	23041000730001B	Belt Protection Cover, Black	1
136	23062000495000A	Rocker Bracket, T=2, 76 x 32 x 30, Black	1

model no. 060-3732-6 | contact us 1-844-428-7277

SPECIFICATIONS

#	Part Number	Description	Qty.
137	21066000135000A	Cable Protective Sleeve, Black	1
138	23063000305000B	Rocker, Ø10 × 875, Black	1
139	23061000220001B	Rocker Sheath, Ø10.5, Black	1
140	23092000015000A	Adjusting Washer, Ø6.1 × Ø15 × 1.6, Black	1
141	23068000225000A	Throwing Snow Cable Assembly, 1164 mm	1
142	23032000205000A	Disc Washer, T=2.5, White Zinc	2
143	23062000270001N	Lower Handle, Black	1
144	21061000113201A	Curved Washer, PA6+GF30, Black	4
145	23099000035000A	Flat Head Bolt, M8 × 52, White Zinc	4
146	23063000580001A	Left Upper Handle Assembly, Black	1
147	23099000025000A	Flat Head Bolt, M8 × 35, White Zinc	4
148	23093000185000A	Special Bolt, M8 × 55, White Zinc	2
149	23062000150001B	Left Trigger, Black	1
150	20121000315000A	Open End Wrenches, 10-12 mm, White Zinc	2
151	23061000140001C	Handle Sheath, PVC, Black	2
152	23063000195000B	Gear Connecting Rod, 547 × Ø8, Black	1
153	23063000215000A	Column, Gear Connecting Rod, White Zinc	1
154	23065000195000A	Speed Adjustment Handle, 229 × 90 × 29, Black	1
155	23068000135000B	Gear Pressing Spring, Ø14.5 × 33.75, White Zinc	1
156	30113010115000	Self-Driving Screw, ST3 × 12, Black Zinc	3
157	23061000150001B	Gear Handle, Left, Black	1
158	23061000160001B	Gear Handle, Right, Black	1
159	23093000195000A22	B Pin, White Zinc, Ø2 × 28 × 11.1	4+4
160	23096000015000A	Rubber Sheath	2
161	30313030015000	Hexagon Nut, M6, Black Zinc	2
162	23089000035000A	AC power cord, 1830mm	1

Page intentionally left blank

SPECIFICATIONS

SPECIFICATIONS

ENGINE PARTS LIST DIAGRAM

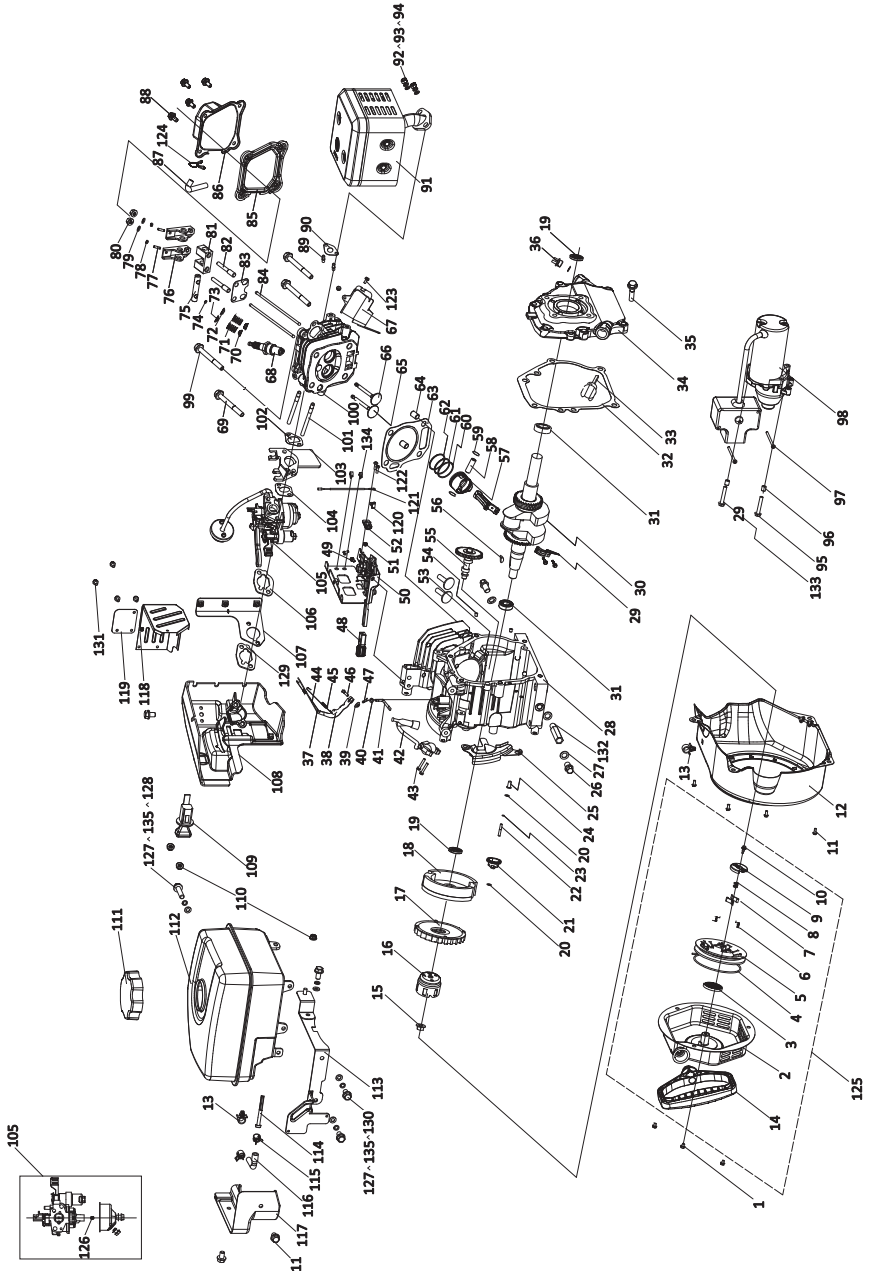

PARTS LIST

#	Part Number	Description	Qty.
1	1.5789.0608.1	Flange Bolt M6 × 8	3
2	26.061100.00.1	Cover, Recoil Starter, Black	1
3	21.061005.00	Spring, Recoil Starter	1
4	2.10.003	Rope Ø5 × 1550	1
5	21.061001.01	Reel, Recoil Starter	1
6	45.060003.00	Spring, Ratchet	2
7	45.060002.00	Starter Ratchet, Steel	2
8	45.060009.00	Spring Guide, Ratchet	1
9	45.060007.00	Ratchet Guide	1
10	45.060008.00	Screw, Ratchet Guide	1
11	1.5789.0612.1	Flange Bolt M6 × 12	6
12	26.080100.00.25	Fan Cover, Green	1
13	2.05.009	Clamp Ø12.5 × 7	2
14	23.061006.01	Handle, Recoil, Soft	1
15	2.02.006	Nut M14 × 1.5	1
16	23.060001.01	Pulley, Starter	1
17	23.080001.00	Cooling Fan	1
18	24.120100.12	Flywheel	1
19	2.11.001	Oil Seal Ø25 × Ø41.3 × 6	2
20	2.03.020.1	Washer Ø6.2 × Ø15 × 0.5, Black	2
21	21.110100.00	Gear, Governor	1
22	21.110013.00	Shaft, Governor Gear	1
23	21.110011.00	Clip, Governor Gear	1
24	21.110012.01	Bushing, Governor Gear	1
25	26.080600.00	Air Guide, Right	1
26	2.08.037	Drain Bolt M10 × 1.25 × 25	2
27	2.03.016	Washer Ø10 × Ø16 × 1.5, Drain Bolt	3
28	27.030100.04	Crankcase	1
29	27.050200.00	Connecting Rod	1
30	27.050100.02	Crankshaft	1
31	1.276.6205.5	Bearing 6205 C5	2
32	24.030008.00	Gasket, Crankcase Cover	1
33	22.031000.00.1	Oil Dipstick Assembly, Black	1
34	24.030007.00	Cover, Crankcase	1
35	1.5789.0832.0.8	Flange Bolt M8 × 32	6
36	22.031000.01.1	Oil Filler Cap, Black	1
37	23.110005.01	Spring, Throttle Return	1
38	27.110003.00	Arm, Governor	1

#	Part Number	Description	Qty.
39	1.6177.06	Flange Nut M6	1
40	2.03.021.1	Washer Ø6.4 × Ø13 × 1, Black	1
41	21.110001.00	Shaft, Governor Arm	1
42	26.123000.00	Ignition Coil, Silicone Rubber	1
43	1.5789.0625	Flange Bolt M6 × 25	2
44	23.110006.00	Rod, Governor	1
45	27.110007.01	Spring, Governor	1
46	2.08.040	Bolt M6 × 21, Governor Arm	1
47	21.110008.00	Pin, Shaft	1
48	24.111008.01.25	Grip Sheath, Speed Governor, Green	1
49	1.5789.0612	Flange Bolt M6 × 12	2
50	26.111000.00	Control Assembly	1
51	1.6177.1.04.2	Flange Nut M4	1
52	26.120006.00	Insulation Board	1
53	25.040013.00	Lifter, Valve	2
54	2.04.001	Dowel Pin Ø9 × 14	2
55	27.041000.01	Camshaft	1
56	2.14.012	Woodruff Key 4 × 7.5 × 19	1
57	27.050005.00	Piston	1
58	23.050003.00	Pin, Piston	1
59	2.09.001	Circlip Ø18 × Ø1	2
60	27.050303.00	Ring, Oil	1
61	27.050302.00	Ring, Second Piston	1
62	27.050301.00	Ring, First Piston	1
63	27.030009.01	Gasket, Cylinder Head	1
64	2.04.003	Dowel Pin Ø10 × 14	2
65	23.040002.02	Valve, Intake	1
66	23.040006.02	Valve, Exhaust	1
67	26.080400.00	Air Guide, Lower	1
68	2.15.002(F6RTC)	Spark Plug F6RTC	1
69	1.5789.0865	Flange Bolt M8 × 65	3
70	23.040017.00	Oil Seal, Valve	2
71	21.040003.00	Spring, Valve	2
72	21.040007.00	Retainer, Exhaust Valve Spring	1
73	21.040001.00	Retainer, Intake Valve Spring	1
74	21.040008.00	Rotator, Exhaust Valve	1

model no. 060-3732-6 | contact us 1-844-428-7277

SPECIFICATIONS

#	Part Number	Description	Qty.
75	24.040202.00	Shaft, Rocker Arm	1
76	22.040009.00	Rocker Arm	2
77	22.040012.00	Screw, Valve Adjustment	2
78	21.040021.00	Nut M6 × 0.5, Lock	2
79	1.97.1.06	Washer Ø6	2
80	1.6177.1.06	Flange Nut M6	2
81	24.040201.00	Retainer, Rocker Arm	1
82	23.040010.00	Bolt, Rocker Arm	2
83	24.040004.00	Guide Plate, Push Rod	1
84	27.040005.00	Push Rod	2
85	21.020002.01	Gasket, Cylinder Head Cover	1
86	24.021000.01	Cover, Cylinder Head	1
87	23.020001.03	Breather Tube	1
88	1.5789.0615	Flange Bolt M6 × 15	4
89	2.01.010	Stud Bolt M8 × 35	2
90	26.100001.00	Gasket, Exhaust Pipe	1
91	24.101000.07.2	Muffler Assembly	1
92	1.6175.08	Nut M8	2
93	1.848.08	Washer Ø8	2
94	1.93.08	Lock Washer Ø8	2
95	1.5789.0625	Flange Bolt M6 × 25	1
96	2.04.005	Dowel Pin Ø8 × 10	2
97	1.823.0455.1	Bolt M4 × 55	2
98	26.125000.00	Starter Motor Assembly	1
99	2.08.121	Flange Bolt M10 × 65	1
100	26.010100.01	Cylinder Head	1
101	2.01.039	Stud Bolt M6 × 110	2
102	24.130002.00	Gasket, Insulator	1
103	23.130001.00	Insulator, Carburetor	1
104	22.130003.00	Gasket, Carburetor	1
105	27.131000.16	Carburetor	1
106	24.130004.20	Gasket, Air Cleaner	1
107	26.091300.00	Element, Air Cleaner	1
108	26.091000.00	Air Cleaner Assembly	1
109	26.120200.00.3	Ignition Switch, Red	1
110	1.6177.1.06.1	Flange Nut M6	3
111	26.070100.00	Cap, Fuel Tank	1
112	26.071000.00.1	Fuel Tank	1
113	26.128300.00.2	Switch Support	1
114	111.070300.01	Fuel Filter, Fuel Pipe	1
115	2.06.027	Clamp Ø12 × b8	2
116	24.070011.02	Pipe, Ø6.35 × Ø12.7 × 320	1

#	Part Number	Description	Qty.
117	26.070010.00	Veil, Fuel Tank	1
118	26.080011.00.2	Protective Cover, Cylinder Head	1
119	26.080012.00.2	Protective Cover, Spark Plug	1
120	26.120005.00	Flame Sheet	1
121	5.1900.099	Change Wire Flameout	1
122	1.9074.4.0414.2	Screw/Washer Assembly M4 × 14	2
123	1.5789.0608	Flange Bolt M6 × 8	2
124	2.06.046	Clamp Ø10.5 × b8	1
125	26.061000.00	Recoil Assembly	1
126	27.131017.16	Standard Main Jet	1
	27.131017.16.01	Altitude Main Jet	/
127	1.93.06	Lock Washer Ø6	4
128	1.5789.0633	Flange Bolt M6 × 33	1
129	21.130004.00	Gasket, Air Cleaner	1
130	1.5789.0620.1	Flange Bolt M6 × 20	3
131	1.5789.0615.1	Flange Bolt M6 × 15	5
132	24.032000.01	Oil Drain Plug	1
133	1.5789.0629	Flange Bolt M6 × 29	1
134	2.05.005	Clamp Ø6 × 6.5	2
135	1.97.1.06.1	Washer Ø6	4

Page intentionally left blank

SPECIFICATIONS

TROUBLESHOOTING

Problem	Possible Cause	Remedy
Engine fails to start.	Engine flooded.	Repeat start attempts with throttle choke OFF.
	Water in fuel.	Drain tank and refill with fresh fuel.
	Other.	Check carefully the start procedure according to this manual.
Engine starts hard or runs poorly.	Spark plug issues.	Replace the spark plug.
	Fuel cap ventilation is blocked.	Clear the ventilation.
Auger does not rotate.	Foreign material caught in system.	Clean.
	Auger drive belt slipping.	Adjust the belt and wire.
	Auger drive belt broken.	Replace the belt.
	Auger control cable is out of adjustment.	See ADJUSTING AUGER CONTROL CABLE section.
Auger does not stop when the lever is released.	Auger drive belt is out of adjustment.	Adjust the belt.
	Auger drive guide is out of adjustment.	Adjust the guide.
	Auger control cable is out of adjustment.	See ADJUSTING AUGER CONTROL CABLE section.
Snowblower veers to one side.	Tire pressure not equal.	Adjust the tire pressure.
	Wheel spring lock pin is inserted on one side.	Check the wheel locks.
	Shoes are mounted unevenly.	Adjust shoes.
	Scraper blade uneven adjusted.	Adjust scraper blade and shoes.
Snowblower does not drive.	Drive cable out of adjustment.	Adjust drive cable. See ADJUSTING SELF-DRIVE CONTROL HANDLE CABLE section.
	Traction belt worn/broken.	Replace traction drive belt. See REPLACE TRACTION DRIVE BELT section.
	Friction disc worn out.	Repair or replace friction disc. See REPAIR OR REPLACE FRICTION DISC section.

**WARNING**

Before performing any maintenance or cleaning work, always stop engine, disconnect spark plug cable and wait until the auger has come to a standstill.

**CAUTION**

Faults which can not be rectified with the aid of this table may be rectified by a specialist company only (customer service centre).

Additional Limitations

This warranty applies only to the original purchaser and may not be transferred. Neither the retailer nor the manufacturer shall be liable for any other expense, loss or damage, including, without limitation, any indirect, incidental, consequential or exemplary damages arising in connection with the sale, use or inability to use this product.

Notice To Consumer

This warranty gives you specific legal rights, and you may have other rights, which may vary from province to province. The provisions contained in this warranty are not intended to limit, modify, take away from, disclaim or exclude any statutory warranties set forth in any applicable provincial or federal legislation.

Made in China

Imported by

**Trileaf Distribution Trifeuil Toronto,
Canada M4S 2B8**

**Champion Power Equipment, Inc (CPE) and Environment and Climate
Change Canada (ECCC)
Emission Control System Warranty**

Your Champion Power Equipment (CPE) engine complies with Environment and Climate Change Canada (ECCC) emission regulations.

YOUR WARRANTY RIGHTS AND OBLIGATIONS:

CPE is pleased to explain the Emission Control Systems Warranty on your 2017 small off-road engine. New engines must be designed, built and equipped, at the time of sale, to meet ECCC regulations for small non-road engines. CPE must warrant the emission control system on your small off-road engine for the period of time listed below, provided there has been no abuse, neglect, unapproved modification, or improper maintenance of your small off-road engine.

Your emission control system may include parts such as the carburetor, fuel-injection system, the ignition system, catalytic converter and fuel lines. Also included may be hoses, belts, connectors and other emission related assemblies. Where a warrantable condition exists, CPE will repair your small off-road engine at no cost to you including diagnosis, parts and labour.

**MANUFACTURER'S EMISSION CONTROL SYSTEM WARRANTY
COVERAGE:**

This emission control system is warranted for two years, subject to provisions set forth below. If, during the warranty period, emission related part on your engine is defective in materials or workmanship, the part will be repaired or replaced by CPE.

OWNER WARRANTY RESPONSIBILITIES:

As the small off-road engine owner, you are responsible for the performance of the required maintenance listed in your Owner's Manual. CPE recommends that you retain all your receipts covering maintenance on your small off-road engine, but CPE cannot deny warranty solely for the lack of receipts or for your failure to ensure the performance of all scheduled maintenance.

As the small off-road engine owner, you should however be aware that CPE may deny you warranty coverage if your small, off-road engine or a part has failed due to abuse, neglect, improper maintenance or unapproved modifications.

You are responsible for presenting your small off-road engine to an Authorized CPE service outlet, CPE dealer or CPE, Santa Fe Springs, CA., USA as soon as a problem exists. The warranty repairs should be completed in a reasonable amount of time, not to exceed 30 days.

If you have any questions regarding your warranty rights and responsibilities, you should contact:

Champion Power Equipment, Inc.
Customer Service
12039 Smith Ave.
Santa Fe Springs, CA 90670
USA
Tel: 1-877-338-0999
tech@championpowerequipment.com

EMISSION CONTROL SYSTEM WARRANTY

The following are specific provisions relative to your Emission Control System Warranty Coverage.

Emission Control System Warranty (ECS Warranty):

1. APPLICABILITY: The ECS Warranty Period shall begin on the date the new engine or equipment is delivered to its original, end-use purchaser, and shall continue for 24 consecutive months thereafter.

2. GENERAL EMISSIONS WARRANTY COVERAGE

CPE warrants to the original, end-use purchaser of the new engine or equipment and to each subsequent purchaser that each of its small off-road engines is:

a. Designed, built and equipped so as to conform at the time of sale with applicable regulations under the Canadian Environmental Protection Act, 1999 (CEPA 1999).

b. Free from defects in materials and workmanship that cause the failure of a warranted part to be identical in all material respects to the part as described in the engine manufacturer's application for certification for a period of two years.

3. THE WARRANTY ON EMISSION-RELATED PARTS WILL BE INTERPRETED AS FOLLOWS:

a. Any warranted part that is not scheduled for replacement as required maintenance in the Owners Manual shall be warranted for the ECS Warranty Period. If any such part fails during the ECS Warranty Period, it shall be repaired or replaced by CPE according to Subsection "d" below. Any such part repaired or replaced under the ECS Warranty shall be warranted for any remainder of the ECS Warranty Period.

b. Any warranted, emissions-related part which is scheduled only for regular inspection as specified in the Owners Manual shall be warranted for the ECS Warranty Period. A statement in such written instructions to the effect of "repair or replace as necessary", shall not reduce the ECS Warranty Period. Any such part repaired or replaced under the ECS Warranty shall be warranted for the remainder of the ECS Warranty Period.

c. Any warranted, emissions-related part which is scheduled for replacement as required maintenance in the Owner's Manual shall be warranted for the period of time prior to the first scheduled replacement point for that part. If the part fails prior to the first scheduled replacement, the part shall be repaired or replaced by CPE according to Subsection "d" below. Any such emissions-related part repaired or replaced under the ECS Warranty,

shall be warranted for the remainder of the ECS Warranty Period prior to the first scheduled replacement point for such emissions-related part.

d. Repair or replacement of any warranted, emissions-related part under this ECS Warranty shall be performed at no charge to the owner at a CPE Authorized Service Outlet.

e. The owner shall not be charged for diagnostic labour which leads to the determination that a part covered by the ECS Warranty is in fact defective, provided that such diagnostic work is performed at a CPE Authorized Service Outlet.

f. CPE shall be liable for damages to other original engine components or approved modifications proximately caused by a failure under warranty of an emission-related part covered by the ECS Warranty.

g. Throughout the ECS Warranty Period, CPE shall maintain a supply of warranted emission-related parts sufficient to meet the expected demand for such emission-related parts.

h. Any CPE Authorized and approved emission-related replacement part may be used in the performance of any ECS Warranty maintenance or repair and will be provided without charge to the owner. Such use shall not reduce CPE's warranty obligation.

i. Unapproved add-on or modified parts may not be used to modify or repair a CPE engine. Such use voids this ECS Warranty and shall be sufficient grounds for disallowing an ECS Warranty claim. CPE shall not be liable hereunder for failures of any warranted parts of a CPE engine caused by the use of such an unapproved add-on or modified part.

EMISSION-RELATED PARTS INCLUDE THE FOLLOWING: (using those portions of the list applicable to the engine)

Systems covered by this warranty	Parts description
Fuel Metering System	Fuel regulator, carburetor and internal parts
Air Induction System	Air cleaner, intake manifold
Ignition System	Spark plug and parts, magneto ignition system
Exhaust System	Exhaust manifold, catalytic converter
Miscellaneous Parts	Tubing, fittings, seals, gaskets, and clamps associated with these listed systems.
Evaporative Emissions	Fuel tank, fuel cap, fuel line, fuel line fittings, clamps, pressure relief valves, control valves, control solenoids, electronic controls, vacuum control diaphragms, control cables, control linkages, purge valves, vapour hoses, liquid/ vapour separator, carbon canister, canister mounting brackets, carburetor purge port connector

TO OBTAIN WARRANTY SERVICE:

You must take your CPE engine or the product on which it is installed, along with your warranty registration card or other proof of original purchase date, at your expense, to any Champion Power Equipment dealer who is authorized by Champion Power Equipment, Inc. to sell and service that CPE product during his normal business hours. Claims for repair or adjustment found to be caused solely by defects in material or workmanship will not be denied because the engine was not properly maintained and used.

If you have any questions regarding your warranty rights and responsibilities, or to obtain warranty service, please write or call Customer Service at Champion Power Equipment, Inc.

**Champion Power Equipment, Inc.
12039 Smith Ave.
Santa Fe Springs, CA 90670
USA
1-877-338-0999
Attn: Customer Service
tech@championpowerequipment.com**