

CERTIFIED™/MC

model number 060-3744-8 | Contact us: 1-844-428-7277

30" (76 CM) 2-STAGE SNOWBLOWER

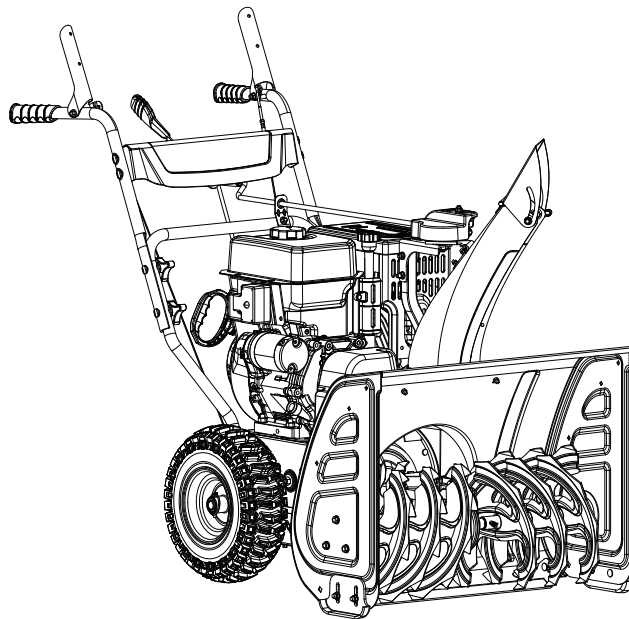

IMPORTANT:

Please read this manual carefully before operating this snowblower and save it for reference.

INSTRUCTION MANUAL



WARNING

MACHINE IS WITHOUT ENGINE OIL, PROPERLY FILL ENGINE OIL PRIOR TO USE TO PREVENT ENGINE DAMAGE.

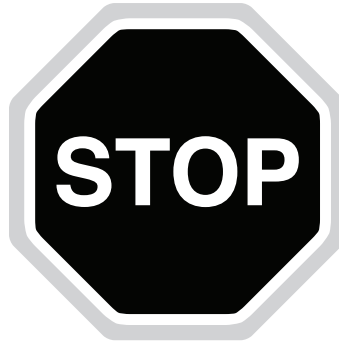

For problems or questions, **DO NOT RETURN TO STORE**. Please contact one of our **Customer Service Agents** who would be happy to assist you.



For Customer Assistance Please Call:
1.844.428.7277

Read and understand this instruction manual thoroughly before using the product. It contains important information for your safety as well as operating and maintenance advice.

Keep this instruction manual for future use. Should this product be passed on to a third party, this instruction manual must be included.

Contact Information.....2

Table Of Contents3

Safety Information4

 General Safety4

 Preparation For Use4

 Safe Handling Of Gasoline4

 Operation5

 Clearing A Clogged Discharge Chute6

 Maintenance And Storage6

 Safety Definitions7

 Safety Symbols.....7

 Operation Symbols8

Features 10

 Know Your Snowblower10

 Engine.....10

Assembly.....12

 Unpacking12

 Additional Parts.....12

 Tools Required.....12

 Assembly Parts.....12

 Assembly.....15

 Handle15

 Speed Control Connecting Lever.....16

 Self-Drive Control Wire And Auger Control Wire16

 Snow Discharge Support17

 Snow Discharge Chute.....17

 Discharge Chute Rotation Lever18

Operation 19

 Before Operation.....19

 Check The General Condition19

 Check The Engine.....19

 Operation19

 Starting The Engine19

 Stopping The Engine21

 Operation At High Altitude21

 Operating The Machine21

 Control Levers.....21

 Drive System.....22

 Adjusting The Snow Discharge Direction And Height22

 Adjusting The Snow Shoes23

 After Use.....24

Maintenance24

 Servicing24

 Safety Precautions.....24

 Maintenance25

 Regular Service Periods.....25

 Refueling26

 Adding Fuel26

 Check Engine Oil Level26

 Oil Change27

 Replacing Shear Pins28

 Adjusting Self-Drive Control Handle Cable.....29

 Adjusting Auger Control Cable.....29

 Replace Auger Drive Belt Without Splitting
 The Snowblower Body (Option 1)30

 Replace Auger Drive Belt –
 Splitting The Snowblower Body (Option 2)34

 Repair Or Replace Friction Disc.....36

 Lubrication.....38

 Long-Term Storage.....38

 Transporting.....38

Specifications 39

 Snowblower Specifications.....39

 Engine Specifications.....39

 Oil Specifications39

 Fuel Specifications.....39

 Parts List Diagram40

 Parts List.....41

 Engine Parts List Diagram.....46

 Parts List.....47

Troubleshooting 50

Warranty Information.....51

 2-Year Limited Warranty.....51

 Additional Limitations.....52

 Notice To Consumer52

SAVE THESE INSTRUCTIONS

This manual contains important safety and operating instructions. Read all instructions and follow them with use of this product.

GENERAL SAFETY

1. Read the operating and service instruction manual carefully. Be thoroughly familiar with the controls and the proper use of the equipment. Know how to stop the unit and disengage the controls quickly.
2. Never allow children under 16 years old to operate the equipment. Never allow adults to operate the equipment without proper instruction.
3. Thrown objects can cause serious injury. Keep the area of operation clear of all persons, particularly small children, and pets. Plan your snow discharge pattern to prevent throwing material toward cars, structures, roads and people.
4. Exercise caution to avoid slipping or falling, especially when operating in reverse.
5. Keep in mind that the operator or user is responsible for accidents or hazards occurring to other people or their property.
6. Never use the snowblower under the influence of alcohol or medication, or if you are tired or ill.
5. Never attempt to make any adjustments while the engine is running (except where specifically recommended in the manual).
6. Let engine and machine adjust to outdoor temperatures before starting to clear snow.
7. The operation of any powered machine can result in foreign objects being thrown into the eyes. Always wear safety glasses or eye shields during operation, or while performing an adjustment or repair.
8. Inspect the auger and impeller before starting to ensure that there is no ice build up.

SAFE HANDLING OF GASOLINE

To avoid severe injury or property damage use high levels of care while handling gasoline. Gasoline is an extremely flammable substance and the vapours are explosive. Serious personal injury can occur when gasoline is spilled on yourself or your clothes, which can ignite. If you come into contact with gasoline, wash affected areas of skin and change clothing immediately.

PREPARATION FOR USE

1. Thoroughly inspect the area where the equipment is to be used and remove all doormats, sleds, boards, wires, and other foreign objects.
2. Disengage all clutch handles before starting the motor.
3. Do not operate the equipment without wearing adequate winter garments. Wear footwear which will improve footing on slippery surfaces.
4. Adjust the auger housing height to clear gravel or crushed rock surface.
1. Use only an approved gasoline container.
2. Extinguish all cigarettes, cigars, pipes and other sources of ignition prior to working with or near gasoline.
3. Never refuel machine within closed spaces.
4. Never remove gas cap or add fuel while the engine is hot or running.
5. Allow engine to cool at least two minutes before refueling.
6. Do not over fill fuel tank. Keep fuel level at least ½ in. (1.27 cm) below bottom of filler neck to provide space for fuel expansion.
7. Replace gasoline cap and tighten securely.

8. If gasoline is spilled, wipe it off the engine and equipment. Move machine to another area. Wait 5 minutes before starting the engine.
9. Never store the machine or fuel container inside where there is an open flame, spark or pilot light (e.g. furnace, water heater, space heater, clothes dryer etc.).
10. Allow machine to cool at least 5 minutes before storing.
11. Never fill containers inside a vehicle or on a truck or trailer bed with a plastic liner. Always place containers on the ground away from your vehicle before filling.
12. If possible, remove gas-powered equipment from the truck or trailer and refuel it on the ground. If this is not possible, then refuel such equipment on a trailer with a portable container, rather than from a gasoline dispenser nozzle.
13. Keep the nozzle in contact with the rim of the fuel tank or container opening at all times until fueling is complete. Do not use gas cans with nozzle lock-open devices.

OPERATION

1. Do not put hands or feet near or under rotating parts. Keep clear of the discharge opening at all times.
2. Exercise extreme caution when operating on or crossing gravel drives, walks, or roads. Stay alert for hidden hazards or traffic.
3. After striking a foreign object, stop the engine, remove the spark plug, thoroughly inspect the snowblower for any damage, and repair the damage before restarting and operating the snowblower.
4. If the unit should start to vibrate abnormally, stop the engine and check immediately for the cause. Vibration is generally a warning of trouble. Vibration typically indicates a mechanical problem has occurred.
5. Stop the engine whenever you leave the operating position, before unclogging the auger housing or discharge guide, and when making any repairs, adjustments, or inspections.
6. Before cleaning, inspecting or repairing any parts of the snowblower ensure the auger has stopped moving. Disconnect the spark plug wire and keep it away from the plug to prevent accidental starting.
7. Before leaving the machine unattended, disengage all control levers, stop the engine and remove the safety key.
8. Do not run the engine indoors. Exhaust fumes are dangerous.
9. Do not clear snow across the face of slopes. Exercise extreme caution when changing direction on slopes. Do not attempt to clear steep slopes.
10. Never operate the snowblower without proper guards, plates or other safety protective devices in place.
11. Never operate the snowblower near glass enclosures, automobiles, window wells, etc., without proper adjustment of the snow discharge angle. Keep children and pets away.
12. Do not overload the machine capacity by attempting to clear snow at too fast a rate.
13. Never operate the machine at high transport speeds on slippery surfaces. Use care when reversing.

14. Never direct discharge at bystanders or allow anyone in front of the unit.
15. Disengage power to the impeller when snowblower is transported or not in use.
16. Use only attachments and accessories approved by the manufacturer of snowblower.
17. Never operate the snowblower without good visibility or light. Always be sure of your footing, and keep a firm hold on the handles. Walk; never run.
18. Take all possible precautions when leaving the machine unattended. Disconnect the power take-off and stop the engine.
19. Keep all nuts, bolts and screws tight to be sure the equipment is in safe working condition;
20. Replace worn or damaged parts for safety; Use only genuine replacement parts and accessories.
21. This snowblower is not intended for use by persons (including children) with reduced physical, sensory or mental capabilities, or lack of experience and knowledge, unless they have been given supervision or instruction concerning use of the appliance by a person responsible for their safety.
22. Be careful while working on the machine or clearing a blockage in the auger or impeller to ensure that fingers and hands do not become crushed or cut.
23. Do not touch hot engine components like the muffler, muffler guard or engine block during operation of the snowblower as they will cause burns.
24. Should the unit stop discharging snow

for any reason, release the controls to stop and inspect for any lodged items or damaged parts in the auger housing.

CLEARING A CLOGGED DISCHARGE CHUTE

Hand contact with the rotating impeller inside the discharge chute is the most common cause of injury associated with snowblowers. Never use your hand to clean out the discharge chute or auger assembly.

To clear the chute:

1. **SHUT THE ENGINE OFF!**
2. Wait 10 seconds to be sure the impeller blades have stopped rotating.
3. Always use a clean-out tool. **DO NOT** use your hands.

MAINTENANCE AND STORAGE

1. Check shear bolts, engine mounted bolts, etc., at frequent intervals for proper tightness to sure the equipment is in safe, working condition.
2. Never store the machine with fuel in the fuel tank inside a building where ignition sources are present such as hot water heaters, space heaters, clothes dryers or any open flame sources. Allow the engine to cool before storing in any enclosure.
3. Always refer to owner's guide instructions for important details if the snowblower is to be stored for an extended period.
4. Maintain or replace safety and instructions labels, as necessary.
5. Run the snowblower for one minute to clear out packed snow and ice to prevent freeze-up during storage.

SAFETY DEFINITIONS

⚠ DANGER

DANGER indicates a hazardous situation which, if not avoided, will result in death or serious injury.

⚠ WARNING

WARNING indicates a hazardous situation which, if not avoided, could result in death or serious injury.

⚠ CAUTION



CAUTION indicates a hazardous situation which, if not avoided, could result in minor or moderate injury.







NOTICE





NOTICE is used to address practices not related to physical injury.

SAFETY SYMBOLS

Some of the following symbols may be used on this product. Please study them and learn their meaning. Proper interpretation of these symbols will allow you to safely operate the product.









Symbol	Name	Designation/Explanation
	Read the Instruction Manual	To reduce the risk of injury, user must read and understand the instruction manual before using this product.
	Eye and Ear Protection	Always wear safety goggles or safety glasses with side shields, and as necessary a full face-shield as well as full ear protection when operating this product. Always wear eye protection with side shields marked to comply with ANSI Z87.1.

Symbol	Name	Designation/Explanation
	Safety Alert	This machine was built to be operated according to the safe operation practices in this manual. As with any type of power equipment, carelessness or error on the part of the operator can result in serious injury. This machine is capable of amputating fingers, hands, toes and feet and throwing foreign objects. Failure to observe the safety instructions could result in serious injury or death.
	Electric Shock	Failure to use the starter in dry conditions and to observe safe practices can result in electric shock.
	Risk of Fire	Fuel and its vapours are extremely flammable and explosive. Fire can cause severe burns or death. Do not add fuel while the product is operating or still hot.
	Toxic Fumes	The engine exhaust from this product contains chemicals known to cause cancer, birth defects and other reproductive harm.
	Risk of Asphyxiation	This engine emits carbon monoxide, an odourless, colourless poison gas. Breathing carbon monoxide can cause nausea, fainting or death. Use only in a well-ventilated area.
	Thrown Objects	This machine may pick up and throw objects which can cause serious personal injury.
	Always Use Chute Tool	Never use your hands to clear a clogged chute assembly. Shut OFF engine and remain behind handles until all moving parts have stopped before unclogging.

Symbol	Name	Designation/Explanation
	Hot Surface	Exhaust gases, muffler and engine components are extremely HOT and cause burns.
	Risk of Fire	Fuel and its vapours are extremely flammable and explosive. Fire can cause severe burns or death. Do not add fuel while the product is operating or still hot.
	Rotating Auger	DANGER: Avoid injury from rotating auger - keep feet away.
	Rotating Blades	Never put your hand in the chute. Contact with rotating parts can amputate fingers and hands.

OPERATION SYMBOLS

Some of the following symbols may be used on this product. Please study them and learn their meaning. Proper interpretation of these symbols will allow you to safely operate the product.

Symbol	Name	Designation/Explanation
	Engine Start	Follow steps to start engine.
	Check Oil Level	Recommended oil is 0W-30. The engine can be seriously damaged without oil. Always check the oil level before using. The machine must be resting firmly on level ground when checking.
	Check Fuel Level	Use clean, fresh, regular unleaded gasoline with a minimum octane rating of 85 and an ethanol content of less than 10% by volume.
	Minimum Octane	Use clean, fresh, regular unleaded gasoline with a minimum octane rating of 85 and an ethanol content of less than 10% by volume.
	Fuel Valve: ON	Move the fuel valve lever to the on position.
	Choke: ON	To start a cold engine, move the choke lever to the choke position.
	Throttle: Full Speed	Move the throttle lever to full speed to start the engine.
	Throttle: Low Speed	Lowers the speed of the engine.

Symbol	Name	Designation/Explanation
	Insert Engine Key	Make sure the engine safety key is inserted into the key hole.
	Cold Prime	To start a cold engine, prime 3-5 times.
	Warm Prime	To start a warm engine, DO NOT prime.
	Recoil Start	Pull the recoil starter grip to start manually.
	Choke: OFF	When the engine starts, move the choke to run position.
	Stop	Follow steps to stop.
	Fuel Valve: OFF	Move the fuel valve lever to the OFF position.
	Remove Engine Key	Remove the engine key.

SAFETY INFORMATION

KNOW YOUR SNOWBLOWER

- 1 Self-Drive Control Handle
- 2 Upper Handles
- 3 Speed Control Connecting Lever
- 4 Handle Locking Knobs
- 5 Lower Handle
- 6 Wheels
- 7 Auger Housing
- 8 Adjustable Skid Shoes
- 9 Auger
- 10 Impeller
- 11 Clean Out Tool
- 12 Discharge Chute
- 13 Discharge Deflector
- 14 Discharge Chute Rotation Lever
- 15 Discharge Chute Lever Guide
- 16 Auger Control Handle
- 17 Speed Adjusting Handle
- 18 Shear Pin and Clip Storage

ENGINE

- 1 Key (safety lock out)
- 2 Primer Bulb
- 3 Throttle Lever
- 4 Choke Lever
- 5 Fuel Valve (On/Off)
- 6 Oil Drain Plug
- 7 Recoil Starter Grip
- 8 Electric Start Button
- 9 Fuel Cap
- 10 Oil Fill and Level Check Cap

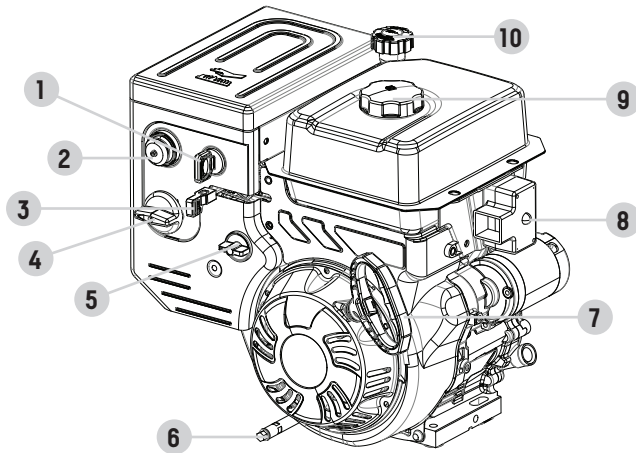
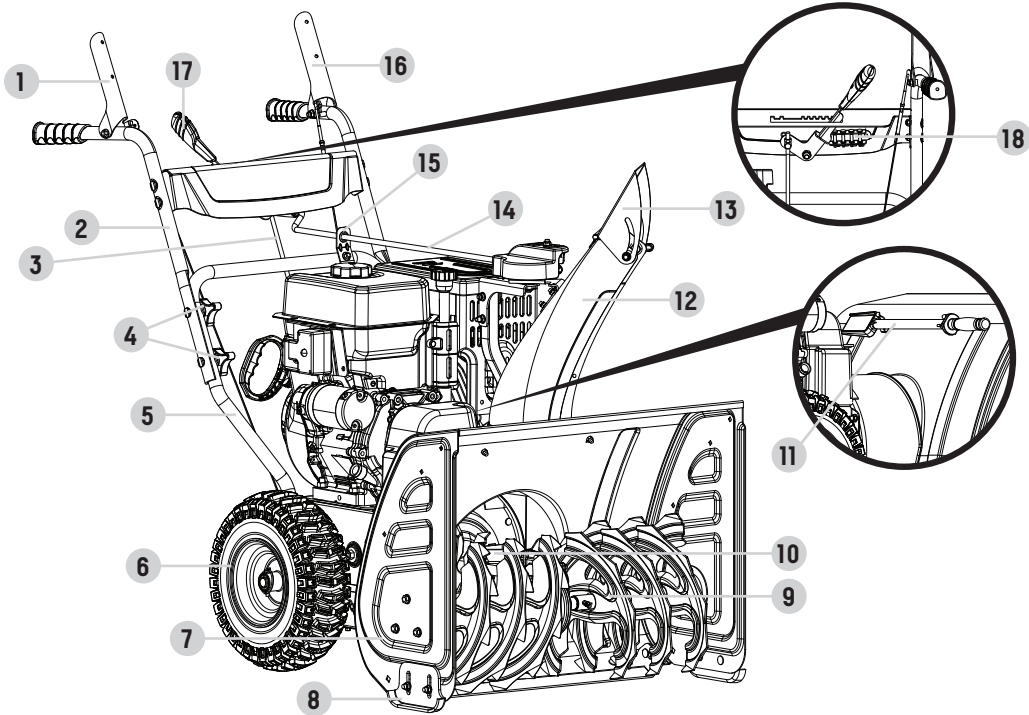

FEATURES

UNPACKING

1. Set the shipping carton on a solid, flat surface.
2. Remove everything from the carton except the snowblower base — including upper and lower handles, connecting levers, chute, hardware, etc. Make sure all the assembly parts are included before you start.
3. Lift the top half of the box off and the base should be clear to start assembly.
4. Cut down the bottom carton to allow a flat surface area to install the assembly parts without scratching parts or cutting tires. Alternatively, with team lift help, lift the base of the snowblower out of the carton and place it on a flattened carton to start assembly.
5. Now you are ready for assembly.

ADDITIONAL PARTS









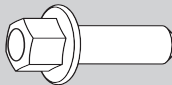
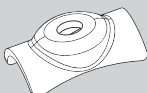

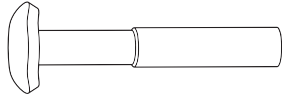
Part	Part Qty.	Usage
Shear Pin (for auger)	4	Spare part
Clip (for auger)	4	Spare part
Starter Electric Cord	1	Accessory

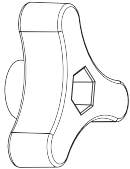
TOOLS REQUIRED

Tool	Size
Wrench (included)	10, 12
Cross-head Screwdriver (not included)	Standard

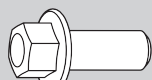
ASSEMBLY PARTS

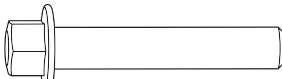
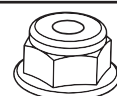
Part	Part Qty.	Hardware Needed	Hardware Qty.	Hardware Reference	Tool(s) Needed
Lower handle	1	M8×45 Hexagon flange bolt (2-2)	2		Size 12 Wrench
	1	M8×20 Hexagon flange bolt (2-3)	2		Size 12 Wrench
		Shaped washer (2-4)	2		N/A

Part	Part Qty.	Hardware Needed	Hardware Qty.	Hardware Reference	Tool(s) Needed
Upper handle	1	M8×52 Flat head bolts (2-5)	4		N/A
		Curved washer (2-6)	4		N/A
		Locking knob V (2-7)	4		N/A
Discharge chute bracket	1	M8×45 Hexagon flange bolt (2-8)	1		Size 12 Wrench
		M8 All-metal hexagon flange lock nut (2-9)	1		Size 12 Wrench
Speed control connecting lever	1	Clip (3-1)	2		N/A
Snow discharge support	1	M6×20 Hexagon flange bolt (preassembled) (4-1)	2		Size 10 Wrench
		M6 All-metal hexagon flange lock nut (preassembled) (4-2)	3		Size 10 Wrench
Snow discharge chute	1	M8×45 Hexagon flange bolt (preassembled) (5-1)	2		Size 12 Wrench
		M8 All-metal hexagon flange lock nut (preassembled) (5-2)	2		Size 12 Wrench
Discharge adjusting lever	1	R pin (preassembled) (5-3)	1		N/A

ASSEMBLY

ASSEMBLY

Part	Part Qty.	Hardware Needed	Hardware Qty.	Hardware Reference	Tool(s) Needed
Auger control handle	1	Auger control wire assembly			N/A
Self-drive control handle	1	Self-drive control wire assembly			N/A

ASSEMBLY

HANDLE

1. Remove wheels before handle assembly. Attach the lower handle (2-1) onto the unit body with bolts (2-2, 2-3) and washers (2-4) (Fig. 1). Repeat on the other side. See Fig. 3 for proper discharge chute bracket mounting hole orientation. Reattach the wheels.

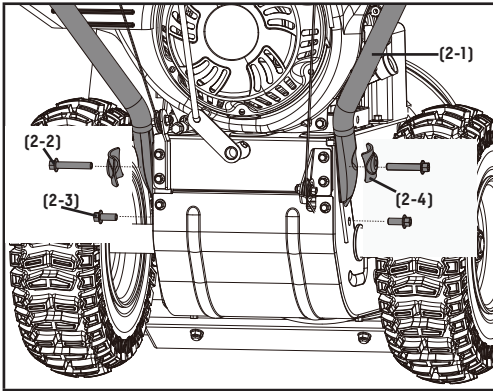

Figure 1

2. Connect the upper handle and lower handle with bolts (2-5), washers (2-6) and locking knobs (2-7) (Fig. 2).

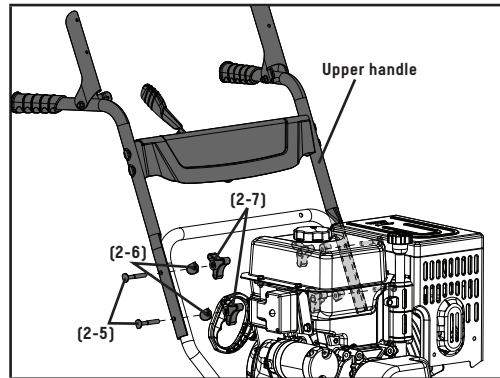

Figure 2

3. Connect discharge chute guide to lower handle with 1 bolt (2-8), and 1 lock nut (2-9) (Fig. 3).

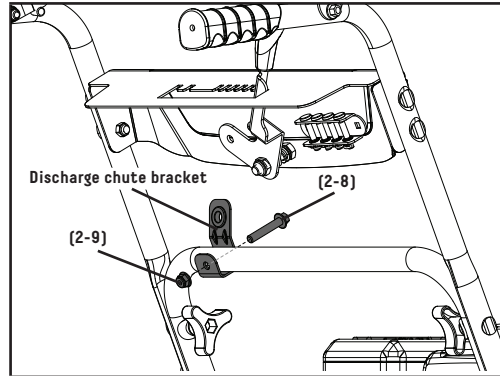

Figure 3

NOTICE:

Only the left axle has two holes, and the axle pin can be removed and repositioned. If the wheel is slid further in on the axle with the pin inserted into the outside hole of the axle, the machine will move freely without the engine on. If the pin is inserted into the inside hole of the axle, the machine will only move when the drive control is engaged when the engine is on.

It is optional to slide one wheel past the pin hole in the axle and to place the locking pin into the axle outside the wheel without locking it into the drive axle. This creates a pivot wheel that allows the operator to easily turn the snowblower during use by using the "free wheel" as a pivot point. Though this makes turning easier, it decreases drive wheel traction by 50%.

Discharge chute bracket should be placed forward as shown (for correct placement). Do not overtighten.

SPEED CONTROL CONNECTING LEVER

1. Connect the connecting lever and connecting base with clip (3-1).
2. Connect the connecting lever and speed adjusting handle with clip (3-1).

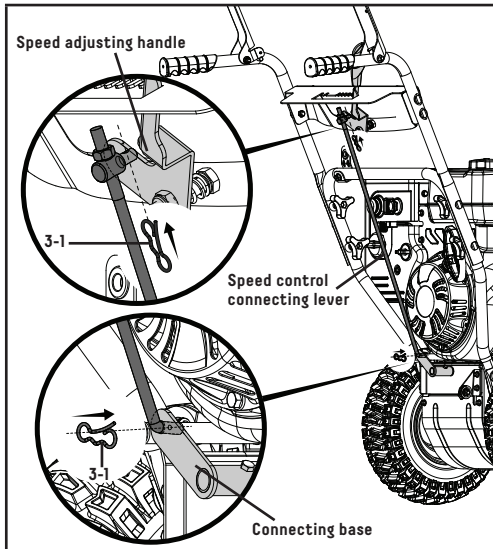

Figure 4

SELF-DRIVE CONTROL WIRE AND AUGER CONTROL WIRE

1. The auger control wire includes part A and part B (Fig. 5).
2. Lift the auger control handle to the upper position (Fig. 5).
3. Hook part A into the auger control handle (Fig. 5).

4. Connect part A and part B of the auger control wire to get a natural tension station for the wire. (Fig. 5)
5. Hook the self-control wire into the self-drive handle in the same way.

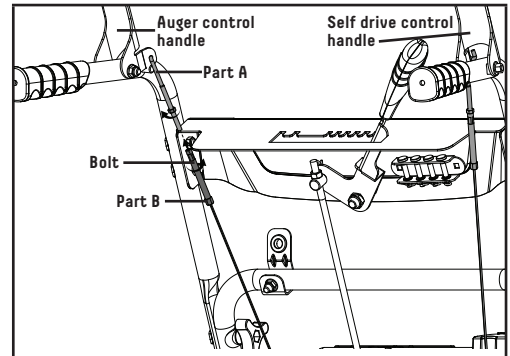

Figure 5

NOTICE:

In the process of operation, if the auger or drive control handle is too loose, screw the bolt (Fig. 5) of part A to get a natural tension station for the wire.

Check the slack of the tension and adjust accordingly. You want to make sure that the tension on the lower side of the snowblower has 1/4-3/8" (6.4-9.5 mm) of movement. If the slack is greater than 5/8" (16 mm), please adjust. Proper tension is important because you will want your snowblower to move forward properly in heavy snowfalls.

SNOW DISCHARGE SUPPORT

1. Locate the position for assembly (Fig. 6).
2. Remove the bolts (4-1) (Fig. 6) and nuts (4-2) (Fig. 6) from the main body as shown (Fig. 6). Set aside for next step.
3. Align snow discharge support with the main body.
4. Attach the snow discharge support on the main body with bolts (4-1) (Fig. 6).
5. Tighten all nuts (4-2) as shown (Fig. 6). Do not overtighten.

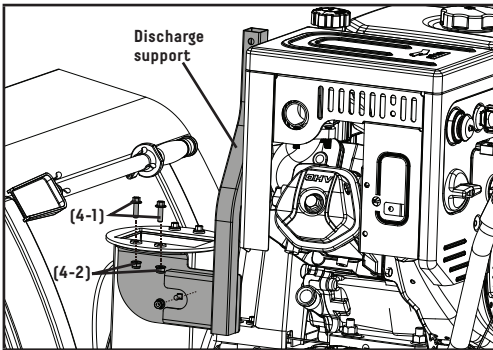

Figure 6

SNOW DISCHARGE CHUTE

1. Remove the bolts (5-1) and nuts (5-2) on the snow discharge support. Hold bolts and nuts for next step. (Fig. 7)
2. Put the snow discharge chute on the base of unit's body. Tighten the component on the snow discharge support using bolts (5-1) (Fig. 7) and nuts (5-2) (Fig. 7). Be careful not to deform the plastic.

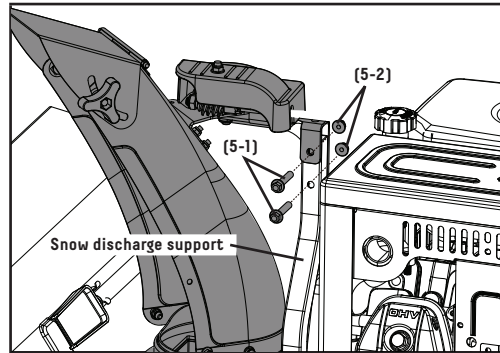

Figure 7

DISCHARGE CHUTE ROTATION LEVER

1. Remove the R pin from the gear as applicable. Set aside for a later step. It may be preinstalled by the factory.
2. Insert the lever through the discharge chute bracket on the lower handle, and then into the hole of the gear (Fig. 8A).
3. Align the lever and the gear, and then connect the R pin (5-3). (Fig. 8B)
4. Check the snow discharge chute by turning it fully in both directions. The discharge chute should rotate freely.

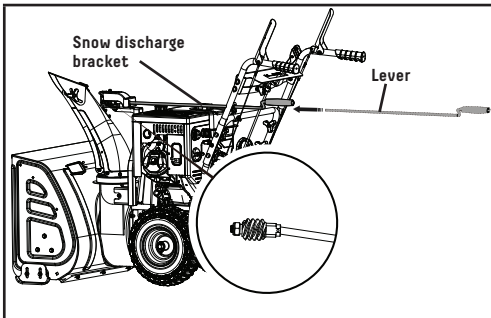

Figure 8A

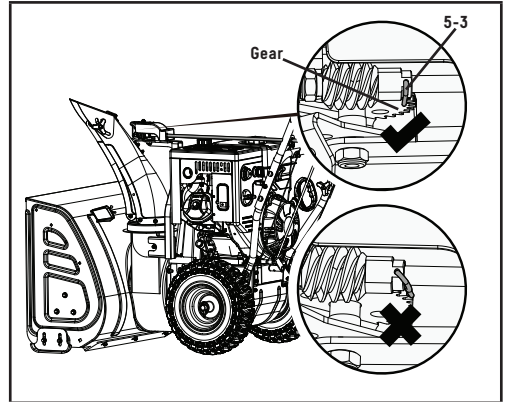

Figure 8B

**WARNING**

Ensure the R pin is positioned as shown in Fig. 8B.

BEFORE OPERATION

CHECK THE GENERAL CONDITION

- Look around and underneath the engine for signs of oil or gasoline leaks.
- Remove any excessive dirt or debris, especially around the muffler and recoil starter.
- Look for signs of damage.
- Check that all shields and covers are in place, and all nuts, bolts, and screws are tightened.

CHECK THE ENGINE

1. There is no fuel or oil in the engine. Fill with fuel and add 0W-30 prior to first use.
2. Check the fuel level (see adding fuel section).
3. Check the oil level (see check engine oil level section).
4. See refueling section for more details.

OPERATION

STARTING THE ENGINE

Read instructions carefully.

1. Make sure the engine safety key is inserted into the key hole (Fig. 9A).
2. Move the fuel valve lever to the on position (Fig. 9A).
3. Move choke lever depending on unit's temperature:
 - a. To start a cold engine, move the choke lever to the choke position (Fig. 9A).
 - b. To start a warm engine, move the choke lever to the run position (Fig. 9B).
4. Move the throttle lever to full speed to start the engine (Fig. 9A).
5. Use primer control depending on unit's temperature (Fig. 9B):
 - a. To start a cold engine, prime 3-5 times.
 - b. To start a warm engine, do not prime.
6. Stand back and to the right of the unit, pull the starter grip lightly until you feel resistance then pull briskly. Return the starter grip gently (Fig. 9C).

NOTICE:

The engine can be seriously damaged without oil. Always check the oil level before using. The machine must stand on level ground when checking.

Engine key and throttle lever plastic piece need to be attached before first use. These parts may be attached to the recoil starter grip. Please remove the key and throttle lever from the recoil starter grip and attach/install properly.



WARNING

Never start the engine until all the above measures under assembly have been carried out.

Never use the snowblower without first reading and understanding the instructions and all the warning and instruction stickers on the machine.

Always use protective goggles or a visor during use, maintenance and service.

7. Alternatively for electric start, plug in the supplied electrical cord into the starter. Press the electric start button and make sure that the main supply voltage is 120 V~ 60 Hz (Fig. 9D).
8. When the engine starts, move the choke to run position (Fig. 9B).

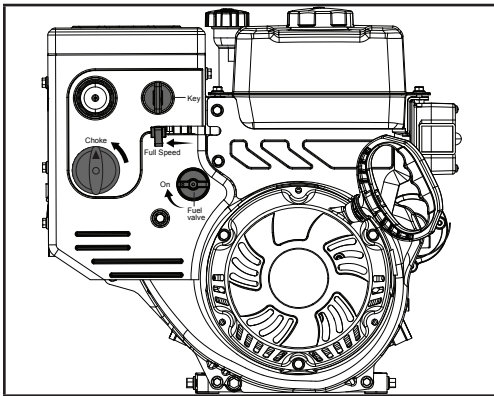

Figure 9A

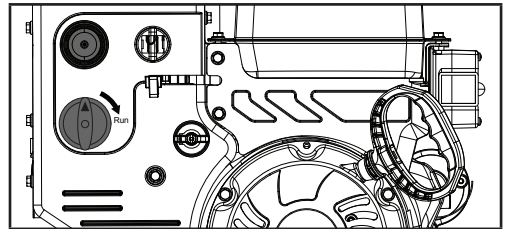

Figure 9B

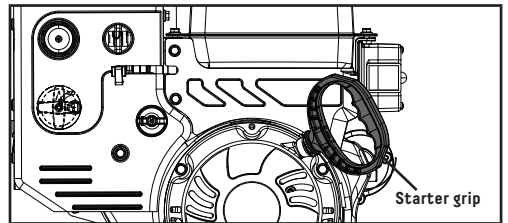

Figure 9C

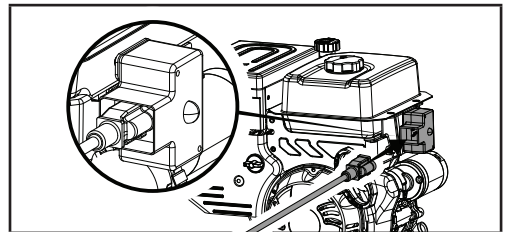

Figure 9D

**WARNING**

Gasoline is highly flammable.

Store fuel in containers specifically designed for this purpose. Refuel outdoors only, before starting the engine, and do not smoke while refueling or handling fuel. Never remove the cap of the fuel tank or add gasoline while the engine is running or when the engine is hot. If gasoline is spilled, do not attempt to start the engine but move the machine away from the area of spillage and avoid creating any source of ignition until gasoline vapours have dissipated. Replace all fuel tanks and container caps securely. Before tipping the snowblower to maintain the blade or drain oil, remove fuel from tank.

WARNING

Never fill fuel tank indoors, with engine running, or until the engine has been allowed to cool for at least 15 minutes after running.

CAUTION

To prevent damaging the electric starter, do not run it more than 10 times at intervals of 5 seconds on, then 5 seconds off. If the engine does not start after this series of attempts, allow the starter to cool for at least 40 minutes before trying to start it again. If the engine still does not start, take the engine to an authorized service centre for service. Once started, disconnect the plug from the power supply and the starter.



STOPPING THE ENGINE

To stop the engine in an emergency situation or during normal operation simply remove the engine key.

OPERATION AT HIGH ALTITUDE







The density of air at high altitude is lower than at sea level. Engine power is reduced as the air mass and air-fuel ratio decrease. Engine power will be reduced approximately 3 ½% for every 1000' (304 m) of elevation above sea level. This is a natural trend and cannot be changed by adjusting the engine. At high altitudes increased exhaust emissions can also result due to the increased enrichment of the air fuel ratio. Other high altitude issues can include hard starting, increased fuel consumption and spark plug fouling. To alleviate high altitude issues other than the natural power loss, we can provide a high altitude carburetor main jet at an additional cost.

The part number and recommended minimum altitude for the application of the high altitude carburetor main jet is listed in the following table. In order to select the correct high altitude main jet, it is necessary to identify the carburetor model. For this purpose, a code is stamped on the side of the carburetor. Select the correct high altitude jet part number corresponding to the carburetor code found on your particular carburetor.

Carburetor Code	Main Jet	Jet Part Number	Altitude
16100-Z520110-0009	Main Jet	16161-Z520110-0000	
	High Altitude	16161-Z520210-0000	914-1828 m (3000-6000')
	High Altitude	16161-Z520310-0000	1828-2438 m (6000-8000')

OPERATING THE MACHINE

CONTROL LEVERS

	Self-drive control handle. Located on the right side handle (Fig. 10).
	When the snowblower has been put into gear, pushing this lever towards the handle engages the wheels.
	Releasing the self-drive control handle causes the machine to stop moving.
	Auger control handle. Located on the left side handle (Fig. 10).
	Pushing this lever towards the handle causes the auger and impeller to activate.
	Releasing the auger control handle causes the auger to stop moving.

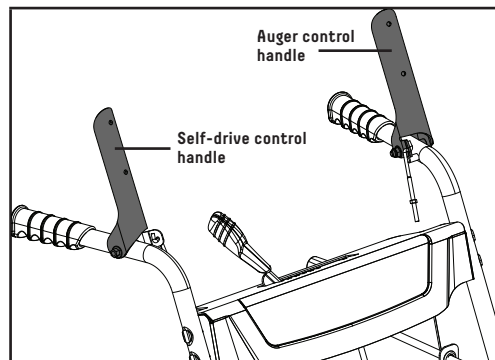

Figure 10



WARNING

Watch out for rotating auger. Keep hands, feet, hair and loose clothing away from any moving parts on the machine.

DRIVE SYSTEM

Your snowblower has 6 forward speeds and 2 reverse to regulate forward and backward motion (Fig. 11).

	Forward speeds range from slowest position 1 to fastest position 6.
	Reverse speeds range from slowest position R1 to fastest position R2 .
	Faster
	Slower

Adjusting the self-propelled drive system:

1. Release the self-drive control handle to bring the snowblower to a stop.
2. Move the speed-control lever to the gear (either forward or reverse) that you require (Fig. 11).
3. Press the self-drive control handle to engage the drive system.

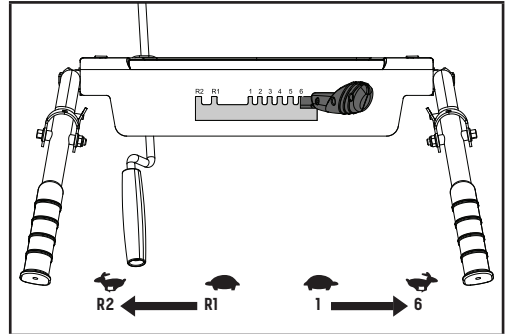

Figure 11

ADJUSTING THE SNOW DISCHARGE DIRECTION AND HEIGHT

Change discharge direction:

	Turn the lever counter-clockwise – the snow discharge guide turns to the left.
	Turn the lever clockwise – the snow discharge guide turns to the right.

Change discharge height:

1. Loosen the locking knob to adjust the snow discharge deflector to a suitable height (Fig. 12).
2. Adjust the snow discharge deflector from 0 – 60°.
3. Tighten the locking knob.



WARNING

If snow clogs the discharge chute do not try to remove it before:

- Releasing the auger control handle.
- Stopping the engine.
- Disconnecting the cable from the spark plug.

Do not put your hand inside the chute or auger. Use the chute clearing tool included with your snowblower.

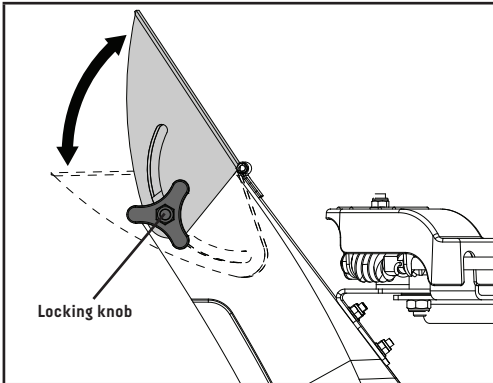
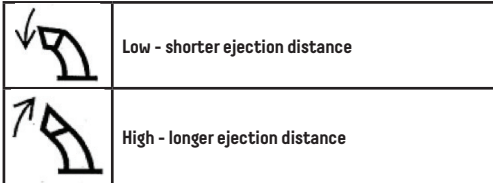

Figure 12

ADJUSTING THE SNOW SHOES

Set the height of the auger housing to suit the ground conditions (Fig. 13):

- On flat ground, e.g. asphalt, the shoes should be adjusted to about 3/16" (5 mm) (the distance from the auger to the ground).

- On uneven ground, e.g. gravel paths, the shoes should be adjusted to about 1 3/16" (30 mm) (the distance from the auger to the ground).

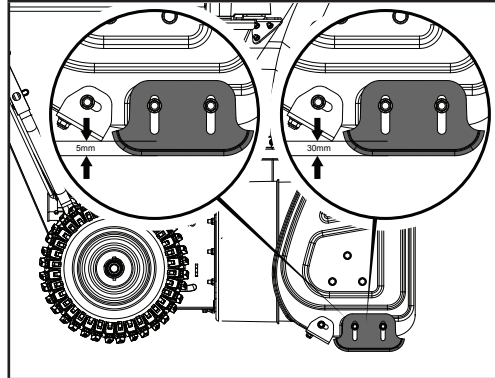

Figure 13

To adjust the shoes:

- Loosen the nuts.
- Move the shoes upward or downward to adjust height.
- Tighten the nuts.



CAUTION

Always adjust the shoes so that gravel and stones are not fed into the snowblower. There is a risk for personal injury if these are thrown out at high speed.

Ensure the shoes are adjusted the same on both sides.

CAUTION

Do not at any time make any adjustments to machine without first stopping the engine and disconnecting the spark plug wire.

CAUTION

Before changing height, stop engine and disconnect spark plug cable.

AFTER USE

1. Check for loose or damaged parts. If required, change damaged parts.
2. Tighten loose screws and nuts.
3. Brush all the snow from the machine.
4. Move all the controls backwards and forwards a few times.
5. Disconnect the starting cable from the spark plug.

SERVICING**SAFETY PRECAUTIONS**

Make sure the engine is off before you begin any maintenance or repair. This will eliminate several potential hazards:

- Carbon monoxide poisoning from engine exhaust — never run the machine indoors. The exhaust fumes contain carbon monoxide, a very toxic gas.
- Burns from hot parts — let the engine cool for 30 minutes before touching hot parts.
- Injury from moving parts — read the instructions before you begin, and make sure you have the tools and skills required.

To reduce the possibility of fire or explosion, be careful when working around gasoline. Use only a nonflammable solvent, not gasoline, to clean parts. Keep cigarettes, sparks and flames away from all fuel-related parts.

**CAUTION**

Do not cover the machine while the engine and silencer are still warm.

MAINTENANCE

REGULAR SERVICE PERIODS

Perform at every indicated month or operating hour interval, whichever comes first.

Item	Service	Each Use	Every month or 20 hrs.	Every 3 months or 50 hrs	Every 6 months or 100 hrs.	Every year or 150 hrs.	
Engine Oil	Check level	<input type="checkbox"/>					
	Change		<input type="checkbox"/>				
Spark Plug	Check-Clean				<input type="checkbox"/>		
	Replace					<input type="checkbox"/>	
Spark Arrester (optional parts)	Clean				<input type="checkbox"/>		
Idle Speed	Check-adjust					<input type="checkbox"/> (1)	
Valve Clearance	Check-adjust					<input type="checkbox"/> (1)	
Fuel Tank and Strainer	Clean					<input type="checkbox"/> (1)	
Fuel Line	Check	Every 2 years (replace if necessary) (1)					

(1) These items should be serviced by your servicing dealer unless you have the proper tools and are mechanically proficient. Refer to manual for service procedures.

MAINTENANCE

REFUELING

Use unleaded gasoline to produce fewer engine and spark plug deposits and extend exhaust system life.

ADDING FUEL

1. Remove the fuel tank cap (Fig. 14).
2. Add fuel to the bottom of the fuel level limit in the neck of the fuel tank. Do not overfill. Wipe up spilled fuel before starting the snowblower.

Fuel tank capacity: 135.3 fl. oz. (4.0 L).

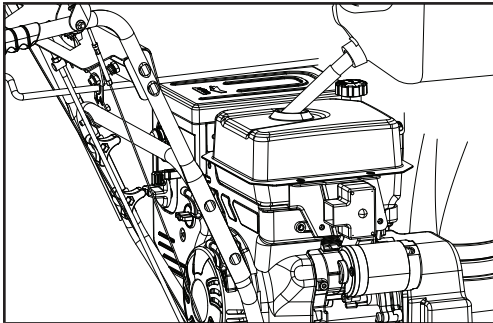

Figure 14

CHECK ENGINE OIL LEVEL

1. Check the oil with engine stopped and level.
2. Remove the oil cap/dipstick and wipe it clean (Fig. 15A).

3. Insert the oil cap/dipstick into the oil filler neck but do not screw it in, then remove it to check the oil level (Fig. 15B).
4. If the oil level is near or below the lower limit mark on the dipstick, remove the oil cap/dipstick, and fill with the recommended oil to the upper limit mark. Do not overfill (Fig. 15B).
5. Reinstall the oil cap/dipstick.

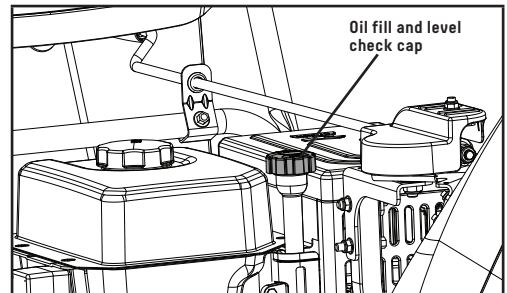

Figure 15A

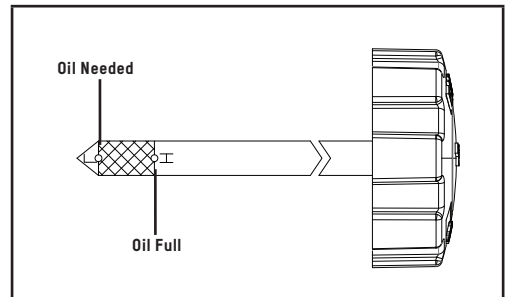

Figure 15B

**WARNING**

Gasoline is highly flammable and explosive, and you can be burned or seriously injured when refueling.

- Stop engine and keep heat, sparks, and flame away.
- Refuel only outdoors.
- Gasoline is poisonous, be careful not to touch or breathe in the vapour.

OIL CHANGE

Drain the engine oil when the engine is warm. Warm oil drains quickly and completely.

1. Turn the fuel valve lever to the OFF position to reduce the possibility of fuel spillage.
2. Place a suitable container below the snowblower to catch the used oil.
3. Remove the drain bolt and drain the oil into the container by slightly tipping the engine toward the oil cap/dipstick (Fig. 16).

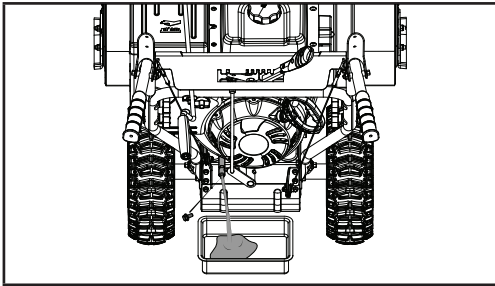

Figure 16

4. With the engine in a level position, fill to the upper limit mark on the dipstick with the recommended oil (0W-30) (Fig. 17).

5. Reinstall the oil cap/dipstick securely.

Capacity of engine oil: 37.2 fl. oz. (1.1 L)

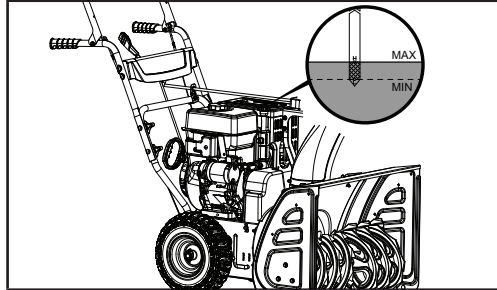

Figure 17



WARNING

- Running the engine with a low oil level can cause engine damage.
- Engine oil is poisonous, be careful not to touch it.
- With engine off but still warm, disconnect the spark plug wire and keep it away from the spark plug.
- We suggest you take used oil in a sealed container to your local recycling centre or service station for reclamation. Do not throw it in the trash, pour it on the ground, or down a drain.

REPLACING SHEAR PINS

The auger housing is shown in Fig. 18A. The augers are secured to the spiral shaft with shear pins (a) and clips (b) (Fig. 18B). If the auger should strike a foreign object or ice jam, the snowblower is designed so that the lock pins may shear.

If the augers will not turn, check to see if the lock pins have sheared (Fig. 18B). Replacement shear pins and clips are found on the back of the control panel. (Fig 18C)

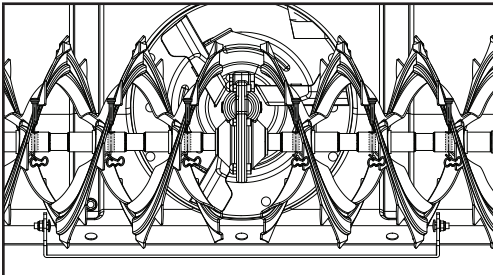

Figure 18A

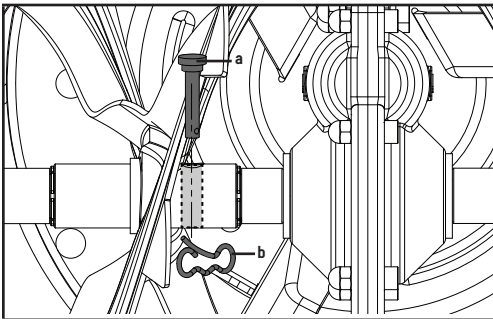

Figure 18B

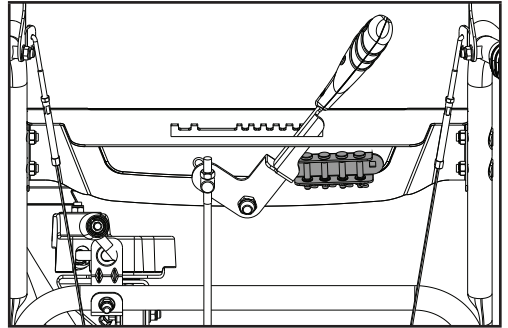

Figure 18C



WARNING

No service must be carried out before:
 The engine has stopped.
 The cable has been disconnected from the spark plug.

ADJUSTING SELF-DRIVE CONTROL HANDLE CABLE

Make sure that the tension on the self-drive cable is adjusted so it has between 1/4-3/8" (6.4-9.5 mm) of movement. This movement can be acquired by measuring the distance the engagement paddle moves from its starting position and the point it becomes taut and starts to move the transmission adjustment lever. If the slack is greater than 5/8" (16 mm), please adjust. Proper tension is important because you will want your snowblower to move forward properly in heavy snowfalls.

While operating the snowblower, if the self-drive control lever is too loose, tighten the nut counter-clockwise while at the same time rotating the bolt upward to reach the position of the nut (Fig. 19).

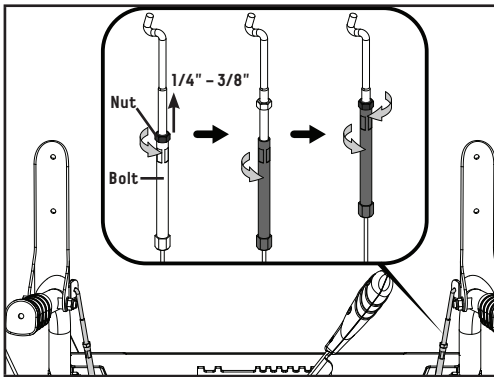

Figure 19

ADJUSTING AUGER CONTROL CABLE

Make sure that the tension on the auger control cable is adjusted so it has between 1/4-3/8" (6.4-9.5 mm) of movement. This movement can be acquired by measuring the distance the engagement paddle moves from its starting position and the point it becomes taut and starts to engage the auger. If the slack is greater than 5/8" (16 mm), please adjust. Proper tension is important because you will want your snowblower to maximize belt life in heavy snowfalls.

While operating the snowblower, if the auger control lever is too loose, tighten the nut counter-clockwise while at the same time rotating the bolt upward to reach the position of the nut (Fig. 20).

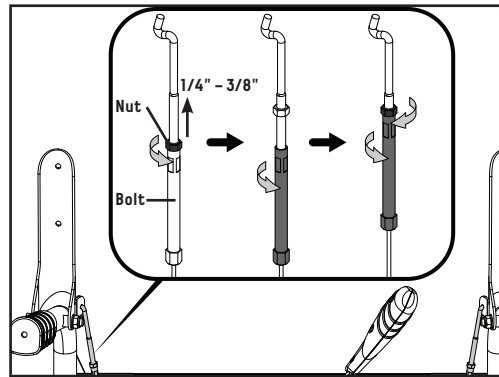

Figure 20

REPLACE AUGER DRIVE BELT WITHOUT SPLITTING THE SNOWBLOWER BODY (OPTION 1)

1. Remove the plastic belt cover (4) on the front of the engine by removing two M6 × 16 bolts (5) (Fig. 21).

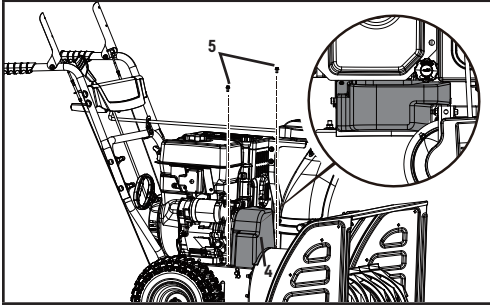

Figure 21

2. Remove clip and washer (Fig. 22A), pull support rod ½ way out from other side of snowblower (Fig. 22B).

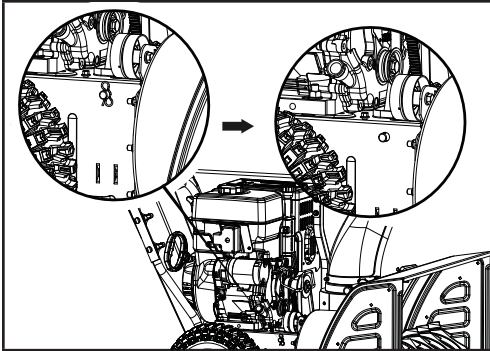

Figure 22A

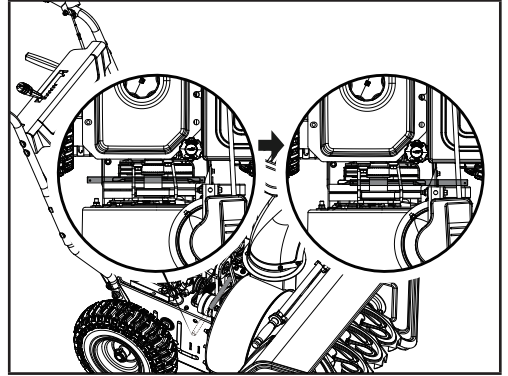

Figure 22B

3. Remove the 2 bolts (20 mm/30 mm) holding the belt guard (Fig. 23). Note the spring is loose at this point.

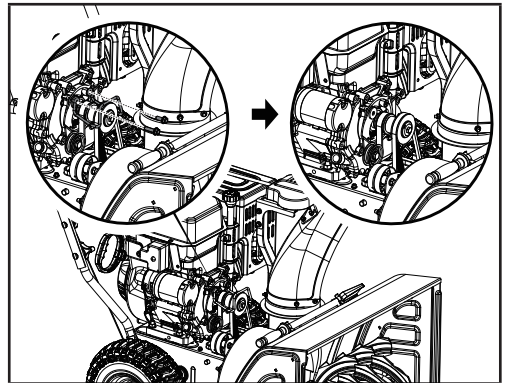

Figure 23

4. Carefully pivot the snowblower up and forward so that it rests on the auger housing. Place a piece of cardboard or moving blanket on the ground before tipping forward. Make sure all fluids are removed and spark plug is disconnected.

- Remove the base frame cover (1) from the underside of the snowblower by removing the six M6 × 16 screws which secure it (Fig 24).

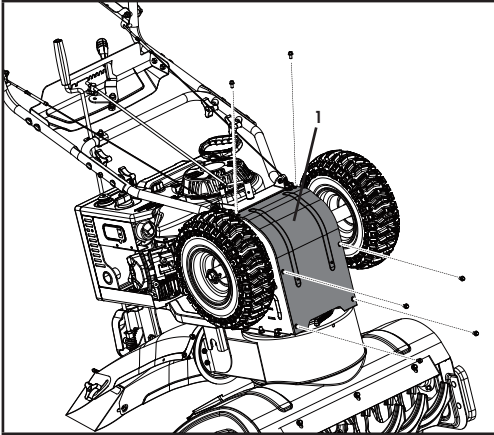

Figure 24

- Slide the speed adjusting handle to the right (Fig. 25A) and remove the loose belt by cutting it or any remaining belt pieces if the belt has already broken (Fig. 25B). If cutting the belt be careful of the tensioning pulley and arm as they are spring loaded and could cause injury when the belt is cut.

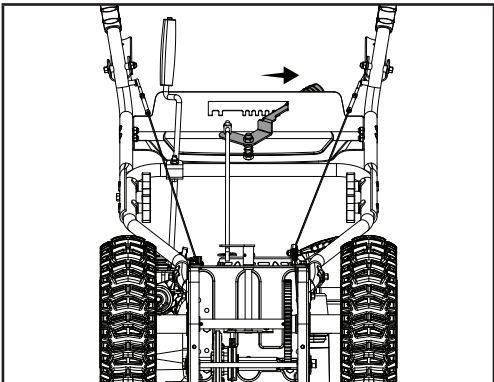

Figure 25A

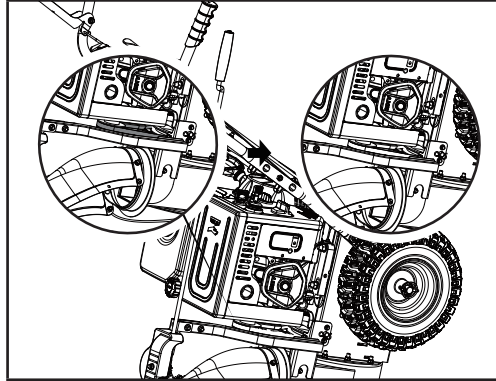

Figure 25B

- Slip the new auger drive belt into the compartment from the bottom of the snowblower placing it around the bottom of the auger drive pulley and slipping it around the front pulley on the engine. Ensure the belt is positioned between the bottom belt guard and the bottom of the auger drive pulley. You may need to remove the bolt holding the lower belt guard in place to properly seat the belt into the pulley, replace the belt guard and bolt after installing the belt into the pulley (Fig. 26A/B).

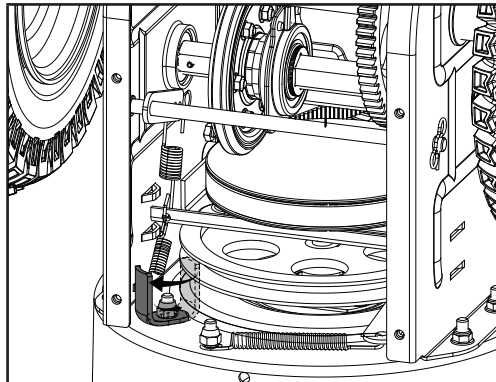

Figure 26A

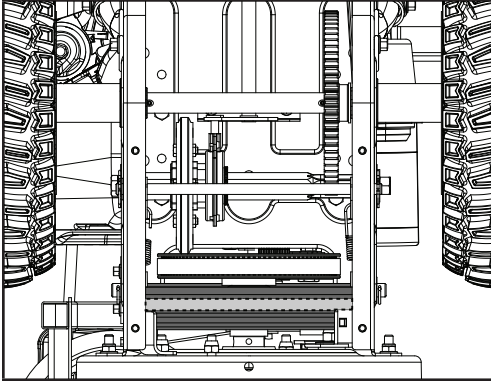

Figure 26B

8. Ensure belt is seated below the belt guide on the idler pulley pivot arm (Fig. 27).

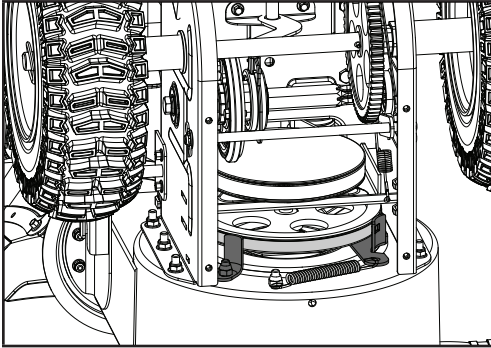

Figure 27

9. With the belt properly placed on both the front pulley and the auger drive pulley, pull the auger idler pulley back away from the belt and slip the belt inside the pulley. You can pull the recoil to rotate the pulley to help get it seated (Fig. 28).

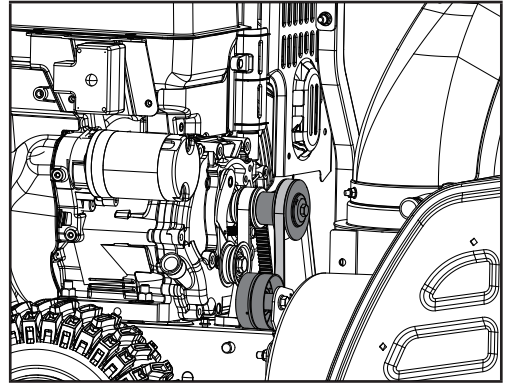

Figure 28

10. Place the belt guard back into place and install the (20 mm/30 mm) bolts that were removed earlier. Once reinstalled, make sure there is equal distance on both sides between the pulley and the guard (Fig. 29).

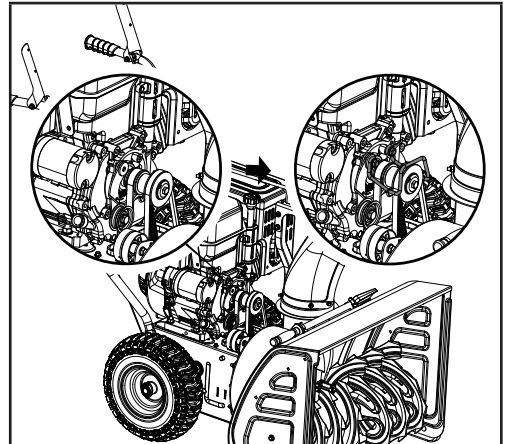

Figure 29

11. Reassemble the support rod by pushing back into place and ensure that it is properly engaged into the friction disc assembly and replace the washer and clip (Fig. 30).

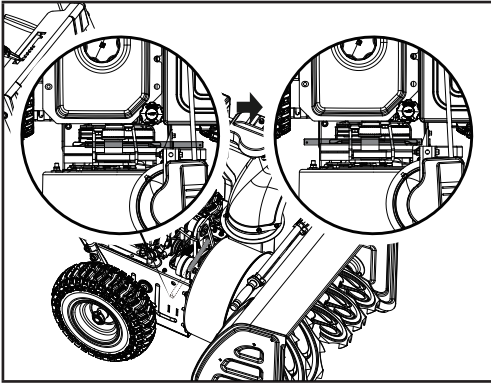

Figure 30

12. Pull the auger control handle to ensure the idler pulley is properly engaging the belt (Fig. 31). Under the belt cover area, make sure the distance on both sides between the guide and pulley is the same.

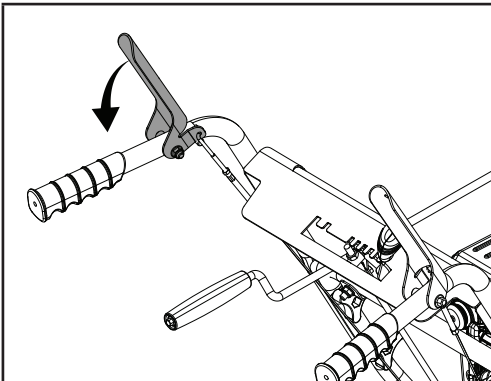

Figure 31

13. Reinstall the base frame cover.
14. Install the plastic belt cover using two M6 × 16 bolts set aside from an earlier step. Torque until snug. Do not overtighten or you risk damaging the plastic belt cover.
15. Perform a drive test to confirm everything is in working order.

REPLACE AUGER DRIVE BELT – SPLITTING THE SNOWBLOWER BODY (OPTION 2)

Tools required:

- Size 10 wrench.
- Size 12 wrench.
- Size 13 wrench (not included).

To remove and replace your snowblower's drive belt, proceed as follows:

1. Remove the plastic belt cover (4) on the front of the engine by removing two M6 × 16 bolts (5) (Fig. 32).

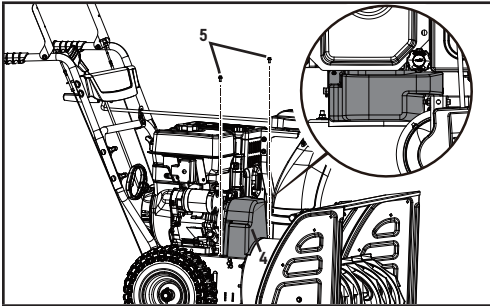

Figure 32

2. Pull out the R pin (Fig. 33).

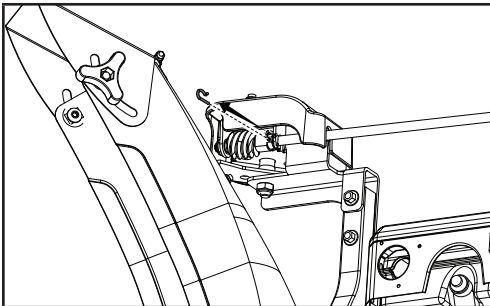

Figure 33

3. Remove the lever from the discharge chute bracket (Fig. 34).

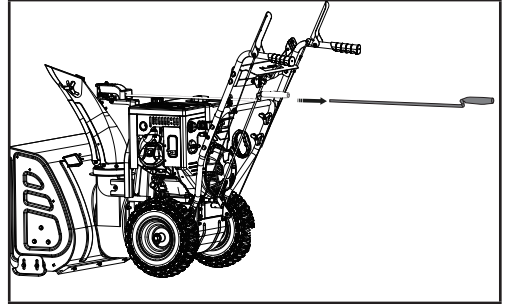

Figure 34

4. Unscrew the bolt of auger control wire (Fig. 35).

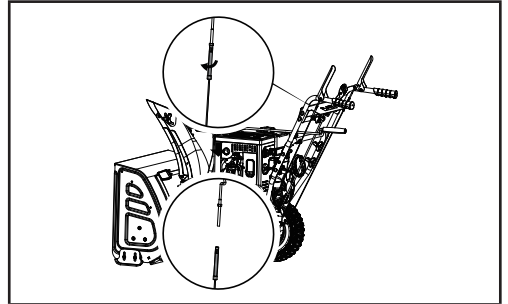

Figure 35

NOTICE:

To prevent spillage, remove all fuel from the tank by running the engine until it stops. Do not attempt to pour fuel from the engine. Disconnect the spark plug before performing any service.

- Remove the 2 bolts (20 mm/30 mm) holding the belt guard (Fig. 36). Note the spring is loose at this point.

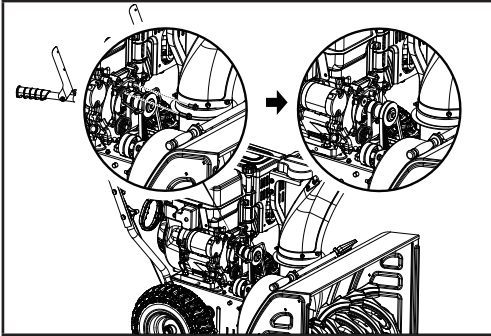

Figure 36

- Unscrew six M8 nuts to separate the auger housing from the base (Fig. 37).

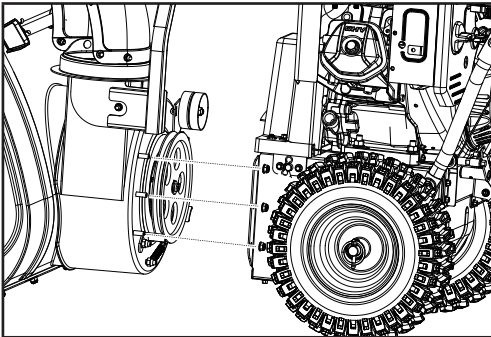

Figure 37

- Unscrew the bolt on the belt guard (Fig. 38).

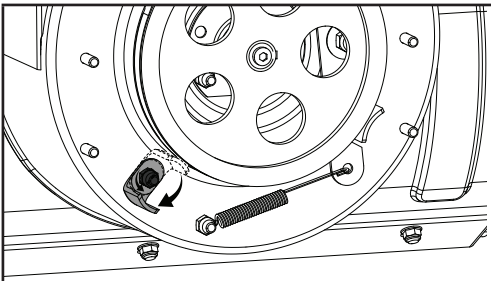

Figure 38

- Slip the drive belt off the pulley. Remove and replace the belt in reverse order ensuring that the new belt is below the spring loaded idler pulley (Fig. 39).

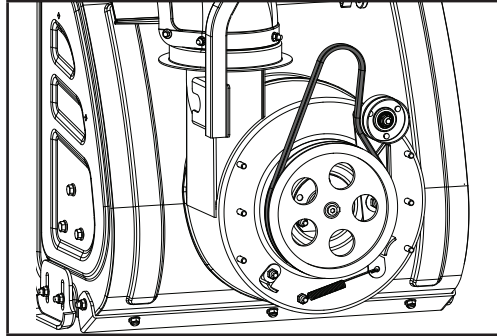

Figure 39

- Place the belt guard back into place and install the bolts (20 mm/30 mm) that were removed earlier. Once reinstalled, make sure there is equal distance on both sides between the pulley and the guard (Fig. 40).

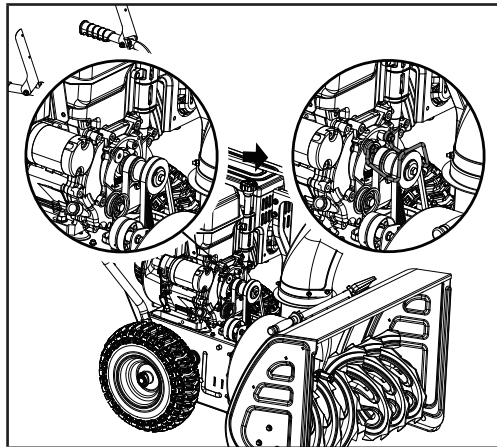

Figure 40

10. Install the plastic belt cover (4) using two M6 × 16 bolts (5) set aside from an earlier step. Torque until snug. Do not overtighten or you risk damaging the plastic belt cover (Fig. 41).

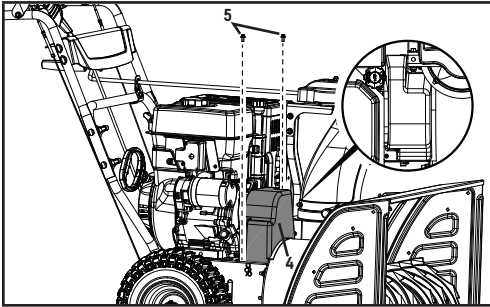

Figure 41

11. Perform a drive test to confirm everything is in working order.

REPAIR OR REPLACE FRICTION DISC

Tools required:

- 10 size wrench.
- 17 size wrench (not included).

To remove and replace your snowblower's friction disc, proceed as follows:

1. Carefully pivot the snowblower up and forward so that it rests on the auger housing. Place a piece of cardboard or moving blanket on the ground before tipping forward. Make sure all fluids are removed and spark plug is disconnected.

2. Remove the base frame cover (1) from the underside of the snowblower by removing the six M6 × 16 screws which secures it (Fig. 42A).
3. Remove the right wheel (2) by removing the axle pin on it (Fig. 42B).

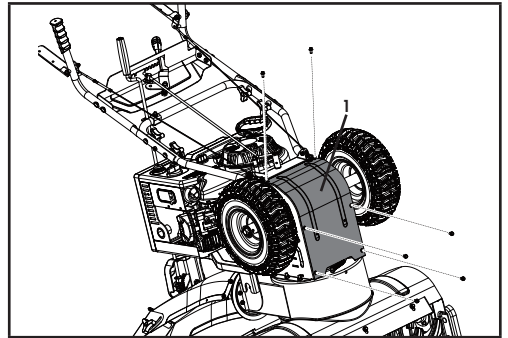

Figure 42A

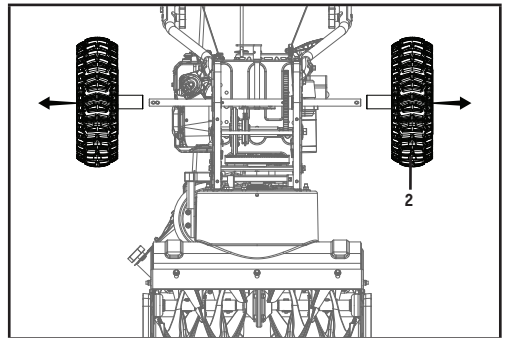

Figure 42B

NOTICE:

If the snowblower fails to drive with the drive control engaged, and performing the drive control cable adjustment fails to correct the problem, the friction disc may need to be replaced.

To prevent spillage, remove all fuel from the tank by running the engine until it stops. Do not attempt to pour fuel from the engine. Disconnect the spark plug before performing any service.

- Carefully remove the M10 hex nut (3) which secures the hex shaft (4) to the snowblower frame and lightly tap the shaft's end to dislodge the ball bearing from the right side of the frame (Fig. 43).

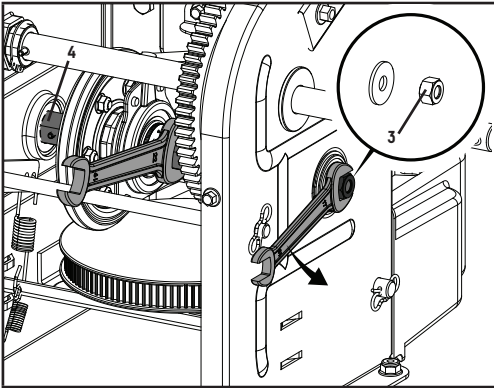

Figure 43

- Carefully position the hex shaft downward and to the left before carefully sliding the friction disc assembly (5) off the shaft (Fig. 44).

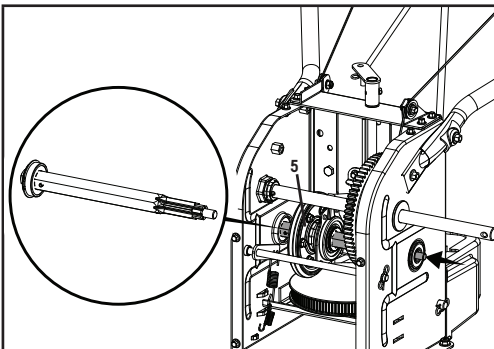

Figure 44

- Unscrew the six M6 × 16 bolts (6) of the friction disc assembly to discard the worn friction wheel rubber ring (7) and replace with a new one (Fig. 45).

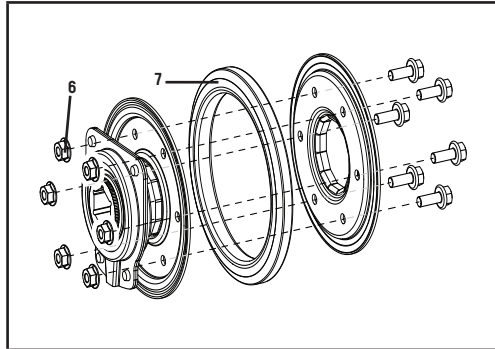

Figure 45

- Follow the previous steps in reverse order to reassemble the parts (Fig. 46).

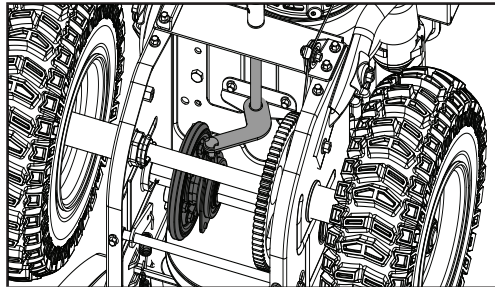

Figure 46

- Perform a drive test to confirm everything is in working order.

LUBRICATION

Lubricate the linkage every 10 hours of use and before long-term storage. Use 0W-30 oil.

No parts inside the gearbox are to be lubricated. All bearings and bushings are permanently lubricated and require no maintenance. Lubricating these parts will only result in the grease getting on to the friction wheel and disc drive plate, which could damage the rubber clad friction wheel.

LONG-TERM STORAGE

Never store the machine with gasoline in the fuel tank in a confined area with bad ventilation. Gasoline fumes could reach open flames, sparks and cigarettes etc.

To avoid the engine freezing and problems starting the engine, leave the engine running for 5-10 minutes after your work has been completed. This will ensure all moisture will disappear that would otherwise cause starting problems.

If the machine is to be stored for a longer period than 30 days, the following procedures are recommended.

1. Start the engine and let it run until it stops due to lack of fuel.
2. Change the engine oil if it has not been done for 3 months.
3. Remove the spark plug and empty a little engine oil (about 1 oz {30 mL}) in the hole. Crank the engine a couple of times. Replace the spark plug.
4. Clean the whole machine thoroughly.
5. Lubricate all the parts as stated in LUBRICATION section above.

6. Inspect the machine for damage, and repair if necessary.
7. Touch up any paint damage.
8. Apply rust protection to the metal surfaces.
9. Store the machine indoors if possible.

TRANSPORTING

If the engine has been running, allow it to cool for at least 15 minutes before loading the machine on the transport vehicle. A hot engine and exhaust system can burn you and can ignite some materials.

Keep the engine level when transporting to reduce the possibility of fuel leakage. Move the fuel valve lever to the OFF position.

SPECIFICATIONS**SNOWBLOWER SPECIFICATIONS**

- Stages..... 2
- Speed Control..... 6 forward/2 reverse
- Auger Diameter..... 12" (30 cm)
- Clearing Width..... 30" (76 cm)
- Clearing Height..... 21" (53 cm)
- Wheel Diameter..... 15" (38.1 cm)

ENGINE SPECIFICATIONS

- Brand..... Champion Power Equipment
- Displacement..... 338 cc
- Engine Model..... R340S
- Start Type..... Electric, Recoil

OIL SPECIFICATIONS

- Oil Capacity..... 37.2 fl. oz. (1.1 L)
- Oil Type..... 0W-30

FUEL SPECIFICATIONS

- Fuel Capacity..... 135.3 fl. oz. (4.0 L)

SPECIFICATIONS

PARTS LIST DIAGRAM

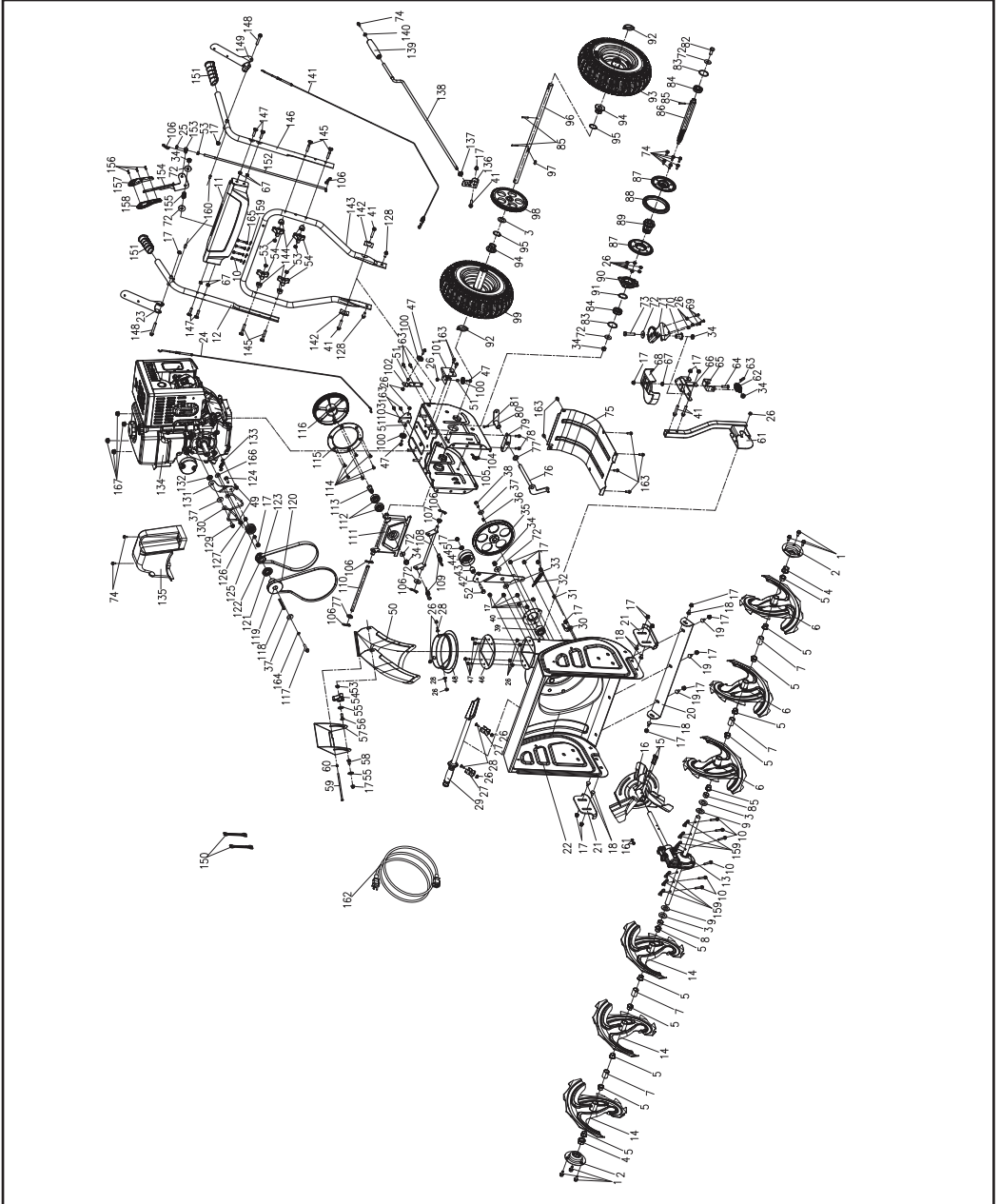

PARTS LIST

#	Part Number	Description	Qty.
1	30913070165000	Hexagon Flange Bolt, M8 x 16, Blue White Zinc	6
2	23052000115000A	Bearing Support, Ø2, White Zinc	2
3	23092000055000A	Flat Washer, Ø20 x Ø37 x 2, Blue White Zinc	8
4	23053000035000A	Bearing Sheath, Auger	2
5	23051000130001B	T Type Bearing Sheath, Auger, Black	12
6	23055000110209N	Left Auger Assembly, Green 7733C	3
7	23051000120001B	Long Bearing Sheath, Auger, Ø19.4 x Ø24.2 x 25.3, Black	4
8	23051000110001B	Short Bearing Sheath, Auger, Ø19.4 x Ø24.2 x 16, Black	2
9	22627000125000A	Wool Felt Washer, Ø40 x Ø20 x 3, White	2
10	23093000215000A	Shear Pin, Blue White Zinc	6+4
11	23043000020001A	Handle Panel Assembly, Black	1
12	23063000570001A	Right Upper Handle Assembly, Black	1
13	23029000035000A	Worm Gear Box Assembly, 30"	1
14	23055000100209N	Right Auger Assembly, Green 7733C	3
15	30223010055000	Hexagon Socket Head Cap Screw, M6 x 40, Black Zinc	2
16	23055000170209A	Fan Impeller Assembly, Green 7733C	1
17	30323060035000	Flange Locking Nut, M8, All Metal Hexagon, Blue White Zinc	29
18	30913090025000	Half-Round Head Square Neck Bolt, M8 x 20, Blue White Zinc	6
19	30913090015000	Half-Round Head Square Neck Bolt, M8 x 16, Blue White Zinc	3
20	23032001450001A	Snow Shovel Plate, 30", Black	1
21	23032000230001N	Sled, Ø5,159.7 x 85,Black	2
22	23035000500001A	Big Housing Assembly, 30", Black	1

#	Part Number	Description	Qty.
23	23062000160001B	Right Trigger, Black	1
24	23068000235000A	Self-Driving Cable Assembly, 970 mm	1
25	30313090025000	Hexagon Locking Nut, M8, White Zinc	1
26	30323060015000	Flange Locking Nut, M6, All Metal Hexagon, Blue White Zinc	22
27	23092000075000A	Bracket, Snow Removal, Ø1.2,39.2 x 30.4 x 13, White Zinc	2
28	30913090035000	Half-Round Head Square Neck Bolt, M6 x 16, Blue White Zinc	4
29	23002000135000	Snow Removal (Shovel) Assembly, Black	1
30	23032000135000A	Belt Support, Ø3,40 x 38 x 20.5, White Zinc	1
31	2303300002A	Bushing, Ø8 x Ø12 x 7, White Zinc	1
32	2303800001A	Tension Spring, 65Mn, Big Tension Wheel, White Zinc	1
33	23034000315000B	Bushing, Ø25 x Ø10.2 x 5.8, Large Tension Board	1
34	23093000125000A	Hexagon Locking Nut, M10, Blue White Zinc	6
35	23034000135000B	Big Triangle Pulley, Ø200 x 15.7, Black	1
36	23093000165000A	Flat Key, 6 x 6 x 15, Black	1
37	23032000335000A	Thickened Big Washer, Ø8.2 x Ø30 x 3.7, White Zinc	3
38	30913040115000	Hexagon Bolt, M8 x 25, Blue White Zinc	1
39	30693010015000	Spherical Bearing	1
40	23052000125000B	Pressing Plate, Bearing, Ø2, Ø95 x 8.5, White Zinc	1
41	30913070065000	Hexagon Flange Bolt, M8 x 45, Blue White Zinc	5
42	23032000255000B	Large Tension Board, Ø3, Black	1
43	23034000345000A	Sheath (Thick), Large Tension Wheel, Ø20 x Ø8 x 16.5	1

SPECIFICATIONS

model no. 060-3744-8 | contact us 1-844-428-7277

SPECIFICATIONS

#	Part Number	Description	Qty.
44	23032000105000C	Large Tension Wheel Assembly, Ø66.5 × 36.2, Ø1.5	1
45	23034000325000A	Sheath (Thin), Large Tension Wheel, Ø20 × Ø8 × 5.5	1
46	23071000210001C	Steering Positioning Plate, Ø158.5 × 4, Black	1
47	30913070105000	Hexagon Flange Bolt, M6 × 20, Blue White Zinc	7
48	23075000165001N	Steering Positioning Block Assembly, Ø195 × 51, Black	1
49	23093000175000A	Hexagon Flange Bolt, 20mm, 5/16" (24UNF-2A), Black Zinc	2
50	23075000120001N	Snow Bucket Assembly, 388 × 295.5 × 164.7, Black	1
51	23033000185000A	Roller Sleeve, White Zinc	3
52	30913040145000	Hexagon Bolt, M8 × 40, Blue White Zinc	1
53	30313060025000	Hexagon Nut, M8, Blue White Zinc	6
54	21061000400001A	Rotating Knob, Black	5
55	23071000140001B	Snow Bucket Washer, Black	2
56	30913090045000	Half-Round Head Square Neck Bolt, M8 × 25, Blue White Zinc	1
57	23075000100001N	Small Snow Bucket Assembly, Black	1
58	23099000045000A	Flat Head Inner Hexagon Bolt, M8 × 17, White Zinc	1
59	23093000155000A	Hinge Pin, Ø5, White Zinc	1
60	30333020025000	Cap Nut, M5, Blue White Zinc	1
61	23075000130001N	Bracket Assembly, 178 × 92.5 × 392, Black	1
62	23073000115000A	Steering Worm, Ø29.2 × 61, White Zinc	1
63	23093000135000A	R Pin, Ø2.5 × 26.3 × 12.3, White Zinc	1
64	30933010035000	Half-Round Head Square Neck Bolt, M8 × 30, Blue White Zinc	1
65	23073000135000A	Worm Bracket, 64 × 40 × 24, Black	1
66	23062000415000C	Connection Plate, T=3.5, 140 × 98.5 × 148	1

#	Part Number	Description	Qty.
67	30333040045000	Serrated Anti-Slip And Anti-Loose Hexagon Flange Nut, M8, Blue White Zinc	5
68	23041000330001A	Worm Protection Cover, Pp+Gf30, Black	1
69	30213020045000	Machine Teeth Screw, M6 × 16, White Zinc	3
70	23024000195000A	Spacer Bushing, Worm Wheel Plate, Ø29 × Ø25.6	1
71	23072000115000B	Worm Wheel Plate, T=3.2, 102.5 × 82.9 × 86.2, Black	1
72	30512050045000	Big Washer, Ø10, Blue White Zinc	8
73	30913030045000	Half-Thread Hexagon Bolt, M10 × 45, White Zinc	1
74	30913070015000	Hexagon Flange Bolt, M6 × 16, Blue White Zinc	9
75	23032000160001N	Big Bottom Plate, Black	1
76	23032000195000A	Gear Shift Fork Assembly, Ø13, White Zinc	1
77	23092000045000A	Flat Washer, Ø14 × Ø25 × 2.5, Blue White Zinc	2
78	30913070125000	Hexagon Flange Bolt, M6 × 10, Blue White Zinc	2
79	23032000185000A	Shifting Fork Plate, T=1.5, 95 × 22 × 26.5, White Zinc	1
80	23062000865000A	Gear Link Plate Assembly, Black	1
81	30913040135000	Hexagon Bolt, M5 × 20, Black Zinc	1
82	30913040065000	Hexagon Bolt, M10 × 20, Blue White Zinc	1
83	23092000065000A	Shaft Ring, Ø38 × Ø43.6 × 1, Black	2
84	23013000025000A	Bearing, 6203Z, 1.6 × 1	2
85	30823060015000	Elastic Column Pin, 4 × 30, Black	3
86	23033000495000A	Wheeled Six Party Shaft, Ø17 × 22 × 253, White Zinc	1
87	23032000285000B	Friction Wheel Clamp, Ø117.6, White Zinc	2
88	23036000105000A	Friction Wheel Rubber Ring, Ø127 × 12.4	1
89	23034000285000B	Wheeled Six Party Sleeve, Ø52 × 52.9	1

#	Part Number	Description	Qty.
90	23032000215000A	Shifting Fork Riveting, White Zinc	1
91	30423010065000	A Type External Circlips, Ø35, Black	1
92	23093000145000A	O Type Elastic Pin, Ø6.2 × 40, Blue White Zinc	2
93	23016000040001A	Left Wheel Assembly, 15 Inch, Black	1
94	23034000255000B	Hexagon Bushing, Ø19 × Ø45 × 25.3	2
95	30423010075000	A Type External Circlips, Ø30, Black	2
96	23013000115000B	Wheel Shaft, Ø19, 22" Black	1
97	31013010045000	Flat Key, 6 × 6 × 18, Black	1
98	23034000765000A	Transmission Gear	1
99	23016000060001A	Right Wheel Assembly, 15 Inch, Black	1
100	23061000130001B	Wire Roller, Black	3
101	23035000125000B	Front Wire Support Seat Assembly, T=2.5, White Zinc	1
102	23032000175000B	Clutch Wire Support Seat, T=2.5, White Zinc	1
103	23062000145000B	Self Driving Wire Support Seat, T=2.5, White Zinc	1
104	23038000125000C	Extension Spring, Ø8.5 × 44.9, White Zinc	1
105	23035000520001A	Housing Assembly, Black	1
106	22698000065000A	B Pin, Ø2"38"18, White Zinc	6
107	23034000355000A	Rocker Arm Spacer Bushing, Ø10.1 × Ø20 × 10	1
108	23032000275000A	Rocker Arm, White Zinc	1
109	23068000125000A	Self-Driving Extension Spring, Ø2.1 × Ø15 × 86.5, White Zinc	2
110	23033000335000A	Bracket Shaft, Ø12.5 × 245	1
111	23035000140001B	Friction Disc Bracket Assembly, Black	1
112	30613010075000	Deep Groove Ball Bearing, 6203RS	2
113	23033000115000B	Large Synchronous Pulley Shaft, Ø17 × Ø20 × 39.3, Black	1

#	Part Number	Description	Qty.
114	30213010035000	Cross Recessed Countersunk Head Screw, M6 × 12, Blue White Zinc	6
115	23034000195000A	Large Synchronous Pulley Side Plate, Ø169.5	1
116	23034000185000C	Large Synchronous Pulley, Ø170	1
117	3091308004	Hexagon Flange Bolt, M8 × 35, Blue White Zinc	1
118	3101301007	Flat Key, B7 × 7 × 60, Black	1
119	23034000745000A	Small Triangle Belt Pulley, Ø25 × Ø72.5 × 51, Black	1
120	23096000035000A	Triangle Belt, 4LXA930	1
121	2303400005A	Small Synchronous Pulley Side Plate	1
122	23034000725000A	Small Synchronous Pulley	1
123	23096000045000A	Synchronous Belt, 800-5M15	1
124	3093301002	Small Half-Round Head Square Neck Bolt, M8 × 35, Blue White Zinc	1
125	23034000265000A	Shaft Sheath, Small Tension Pulley, Ø8 × Ø15 × 6.1	1
126	23032000115000A	Small Tension Pulley Assembly, Ø45 × 19.4	1
127	23034000275000B	Shaft Sheath, Small Tension Pulley, Ø8 × Ø15 × 11.5	1
128	30913070185000	Hexagon Flange Bolt, M8 × 20, Blue White Zinc	2
129	23093000205000A	Hexagon Flange Bolt, 30mm, 5/16" (24UNF-2A), White Zinc	1
130	23033000075008A	Belt Lever, Ø6, Black	1
131	2303200117A	Small Tensioning Plate, T=3,108.5 × 46.7, White Zinc	1
132	2303400059A	Small Tensioning Plate Cushion, 308 × 8	1
133	23038000135000A	Small Tension Pulley Spring, Ø1.5 × Ø10.5 × 69.3, White Zinc	1
134	2030100215A	Engine, R340DS, 338CC	1
135	23031000020001A	Belt Protection Cover, Black	1
136	23062000495000A	Rocker Bracket, T=2,76 × 32 × 30, Black	1

model no. 060-3744-8 | contact us 1-844-428-7277

SPECIFICATIONS

#	Part Number	Description	Qty.
137	21066000135000A	Cable Protective Sleeve, Black	1
138	23063000305000B	Rocker, Ø10 × 875, Black	1
139	23061000220001B	Rocker Sheath, Ø10.5, Black	1
140	23092000015000A	Adjusting Washer, Ø6.1 × Ø15 × 1.6, Black	1
141	23068000025000A	Throwing Snow Cable Assembly, 1184mm	1
142	23032000205000A	Dish Washer, T=2.5, White Zinc	2
143	23062000270001N	Lower Handle, Black	1
144	21061000113201A	Curved Washer, PA6+GF30, Black	4
145	23099000035000A	Flat Head Bolt, M8 × 52, White Zinc	4
146	23063000580001A	Left Upper Handle Assembly, Black	1
147	23099000025000A	Flat Head Bolt, M8 × 35, White Zinc	4
148	23093000185000A	Special Bolt, M8 × 55, White Zinc	2
149	23062000150001B	Left Trigger, Black	1
150	20121000315000A	Open End Wrenches, 10-12 mm, White Zinc	2
151	23061000140001C	Handle Sheath, PVC, Black	2
152	23063000195000B	Gear Connecting Rod, 547 × M8, Black	1
153	23063000215000A	Column, Gear Connecting Rod, White Zinc	1
154	23065000195000A	Speed Adjustment Handle, 229 × 90 × 29, Black	1
155	23068000135000B	Gear Pressing Spring, Ø14.5 × 33.75, White Zinc	1
156	30113010115000	Self-Tapping Screw, ST3 × 12, Black Zinc	3
157	23061000150001B	Gear Handle, Left, Black	1
158	23061000160001B	Gear Handle, Right, Black	1
159	23093000195000A	B Pin, White Zinc, Ø2 × 28 × 11.1	6+4
160	23096000015000A	Rubber Sheath	2
161	30313030015000	Hexagon Locking Nut, M6, Black Zinc	2
162	23089000035000A	AC Start Line, 1830mm	1

#	Part Number	Description	Qty.
163	23033000485000A	Flange Triangle Self-Tapping Screw, M6 × 16, White Zinc	12
164	A26800800202	Spring Washer, Ø8, Black Zinc	1
165	23096000055000A	Rubber Sheath, Ø10.7 × Ø6 × 5.1, Black	4
166	A26800700701	Flat Washer, Ø8, Blue White Zinc	1
167	30323060045000	Hexagon Flange Locking Nut, M10, Blue White Zinc	4

Page intentionally left blank

SPECIFICATIONS

SPECIFICATIONS

ENGINE PARTS LIST DIAGRAM

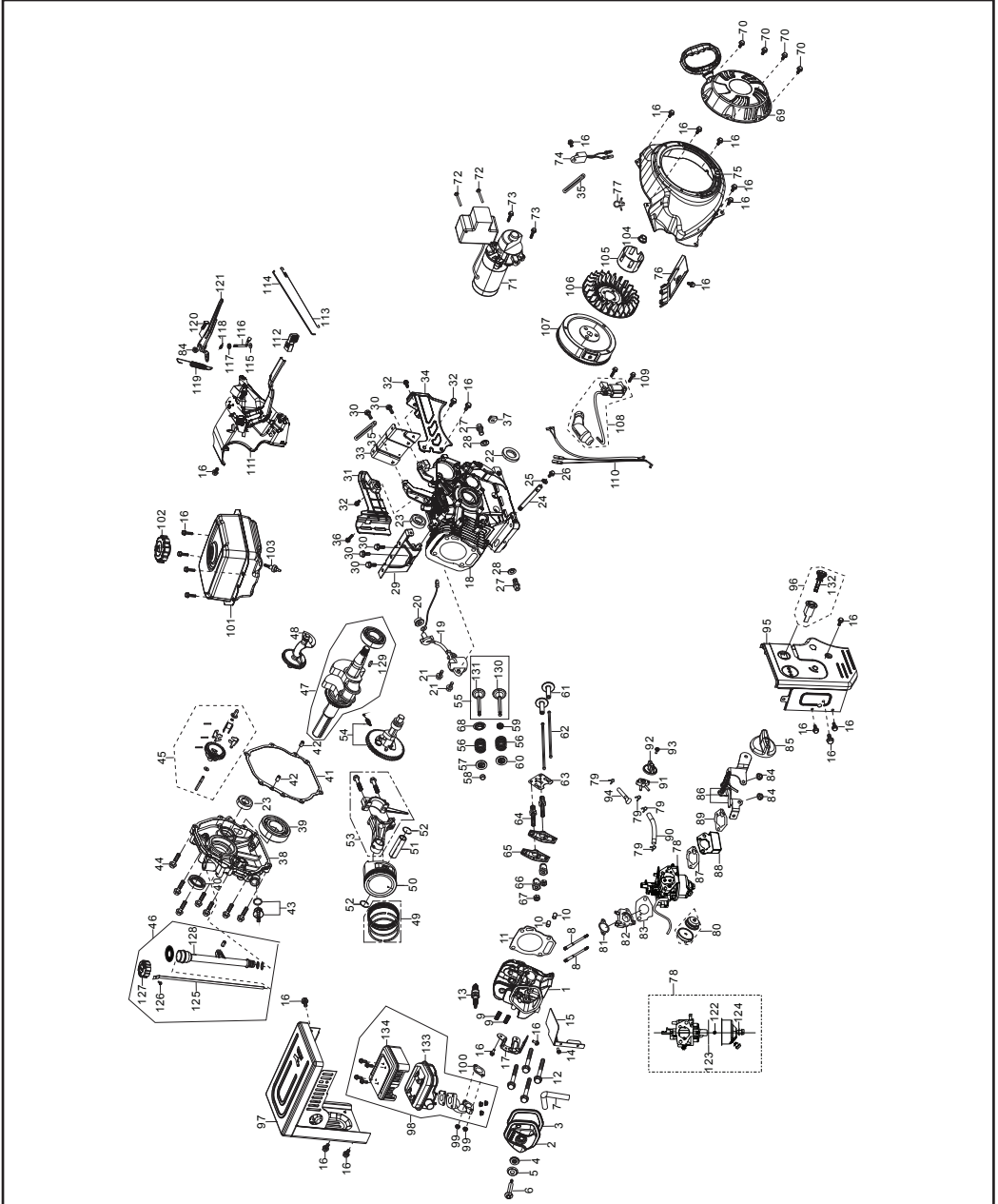

PARTS LIST

#	Part Number	Description	Qty.
1	12140-Z520110-0800	Cylinder Head Subassembly	1
2	12410-Z310110-0000	Cylinder Head Cover Subassembly, Blue White Zinc	1
3	12004-Z090110-0001	Cylinder Head Cover Gasket	1
4	12033-Z080110-0000	Cylinder Head Cover Bolt Gasket	1
5	12031-Z080110-0100	Cylinder Head Cover Gasket, Blue White Zinc	1
6	12032-Z080110-0100	Cylinder Head Cover Bolt, Blue White Zinc	1
7	17004-Z520110-0001	Breather Tube, Ø10.4 x Ø15, NBR+CSM	1
8	90204-Z100510-0000	Stud, M6/M8 x 114, Black Zinc	2
9	90204-Z100320-0000	Stud, M8 x 54, Black Zinc	2
10	90502-1220-00	Pin, 12 x 20	2
11	12131-Z520110-0000	Cylinder Head Gasket	1
12	12003-Z080110-0000	Cylinder Head Bolt, M10 x M80	4
13	30010-Z010110-0000	Spark Plug, F6RTC	1
14	90001-0614-01	Hexagon Flange Bolt, M6 x 14, Blue White Zinc	1
15	80057HZ520210-0000	Front Fender	1
16	90001-0612-01	Hexagon Flange Bolt, M6 x 12, Blue White Zinc	22
17	18299HZ520210-0000	Muffler Outer Cover Support Subassembly	1
18	11310-Z520510-0800	Crankcase Subassembly	1
19	37060-Z080120-0000	Engine oil Sensor, W/O Nut	1
20	90305-Z010210-01	Hexagon Flange Nut, M10, Blue White Zinc	1
21	90001-0616-01	Hexagon Flange Bolt, M6 x 16, Blue White Zinc	2
22	90682-Z0J0110-0001	Oil Seal, Ø40 x Ø52 x 9	1
23	90548-0202-00	Bearing, 6202 P6	2
24	11011-Z520210-0000	Oil Drain Tube, 80 x 16, Blue White Zinc	1
25	90408-Z010110-0000	Washer, Ø10 x Ø15.8 x 1.5	1
26	11007-Z010110-0000	Drain Plug Bolt, M10 x1.25 x15, Blue White Zinc	1
27	11007-Z080110-0000	Drain Plug Bolt, M10 x1.5 x18, Blue White Zinc	2

#	Part Number	Description	Qty.
28	90412-Z080110-0000	Washer, Ø12 x Ø21 x 2	2
29	16612HZ520130-0000	Fuel Tank Mounting Frame	1
30	90001-0820-01	Hexagon Flange Bolt, M8 x 20, Blue White Zinc	5
31	16617-Z520120-0001	Fuel Tank Shield 2	1
32	90001-0620-01	Hexagon Flange Bolt, M6 x 20, Blue White Zinc	3
33	16618HZ520110-0000	Fuel Tank Rear Mounting Frame	1
34	16614-Z520130-0001	Fuel Tank Shield	1
35	90684-Z030120-0000	Clip	2
36	90001-0625-01	Hexagon Flange Bolt, M6 x 25, Blue White Zinc	1
37	28101-Z080110-0001	Rubber Plug, Black	1
38	11411-Z520210-0800	Crankcase Cover	1
39	90548-0207-00	Bearing, 6207 P6	1
40	90682-Z520110-0001	Oil Seal, Ø35 x Ø52 x 7	1
41	11001-Z100120-0000	Crankcase Gasket	1
42	90502-0812-00	Pin, 8 x 12	2
43	15030-Z080130-0801	Engine Oil Plug Subassembly, 0-Type	1
44	90001-0840-01	Hexagon Flange Bolt, M8 x 40, Blue White Zinc	7
45	16400-Z100110-0000	Governor Gear Assembly	1
46	15010-Z520120-0801	Oil Dipstick Subassembly	1
47	13300-Z111110-RB00	Crankshaft Assembly	1
48	13401-Z100110-0000	Balancing Shaft	1
49	13200-Z520210-0000	Piston Rings Set	1
50	13111-Z520210-0000	Piston	1
51	13121-Z100110-0000	Piston Pin, Ø20 x Ø62	1
52	13122-Z100110-0000	Piston Pin Clip	2
53	13010-Z100120-0000	Connecting Rod	1
54	14200-Z520210-0009	Camshaft Assembly	1
55	12110-Z100110-0000	Valves Set	1
56	12103-Z080110-0000	Valve Spring	2
57	12107-Z080110-0000	Exhaust Valve Retainer	1
58	12104-Z080110-0000	Valve Rotator	1
59	12101-Z080110-0000	Seal Guide	1
60	12112-Z080110-0000	Valve Spring Retainer	1
61	14081-Z080110-0000	Valve Lifter	2
62	14070-Z100110-0000	Valve Rod	2

SPECIFICATIONS

model no. 060-3744-8 | contact us 1-844-428-7277

SPECIFICATIONS

#	Part Number	Description	Qty.
63	14090-Z080110-0000	Lifter Stopper Plate Subassembly, Blue White Zinc	1
64	14313-Z010110-0000	Valve Adjusting Bolt	2
65	14311-Z080110-0000	Valve Rocker	2
66	14314-Z010110-0000	Valve Adjusting Nut	2
67	14312-Z010110-0000	Valve Lock Nut	2
68	12105-Z080110-0000	Valve Spring Retainer	1
69	28200-Z520110	Recoil Starter Assembly	1
70	90001-0610-03	Hexagon Flange Bolt, M6 x 10, Blue White Zinc	4
71	30300-Z520110-0002	Starting Motor Assembly	1
72	90103-0455-51	Screw, M4 x 55, Blue White Zinc	2
73	90001-0835-01	Hexagon Flange Bolt, M8 x 35, Blue White Zinc	2
74	37050-Z010210-0000	Oil Protector, Zinc Plated	1
75	28110-Z110110	Shroud	1
76	19304-Z110110-0000	Cylinder Body Shroud, Blue White Zinc	1
77	90684-Z080110-0001	Clip	1
78	16100-Z520110-0009	Carburetor Assembly, Zinc Plated	1
79	90740-Z010210-0000	Clamp, Ø7.5, Blue White Zinc	4
80	16210-Z330110-0001	Primer Bulb	1
81	17002-Z100110-0000	Inlet Gasket	1
82	16003-Z520110-0001	Carburetor Insulator Plate	1
83	16001-Z520110-0000	Carburetor Gasket	1
84	90305-0600-31	Hexagon Flange Nut, M6, Blue White Zinc	3
85	16235-Z520120-VG01	Carburetor Choke Handle Rubber Sleeve	1
86	16900-Z520120-0000	Choke Control Assembly	1
87	17001-Z520210-0000	Air Cleaner Gasket	1
88	16116-Z520110-0001	Oil Cup	1
89	17001-Z520110-0000	Air Cleaner Gasket	1
90	90686-Z520410-0001	Fuel Pipe, Ø4.5 x Ø8.5 x 90	1
91	16752-Z1S0110-0000	Fuel On-Off Switch	1
92	35643-Z1S0110-VG01	Knob	1
93	90103-0314-51	Screw, Blue White Zinc	1
94	90686-Z520310-0001	Fuel Pipe, Ø4.5 x Ø8.5 x 150+25, L-Type	1
95	35610-Z520310-0001	Control Panel Subassembly	1

#	Part Number	Description	Qty.
96	35540-Z330110-0000	Stop Engine Switch Subassembly	1
97	18140-Z520410-H301	Scald Resistant Cover	1
98	18100-Z520120-H302	Muffler Assembly	1
99	90303-0800-31	Hexagon Flange Nut, M8, Blue White Zinc	2
100	18001-Z080110-0000	Exhaust Outlet Gasket	1
101	16620-Z520210-H601	Fuel Tank	1
102	16730-Z330120-Q201	Fuel Tank Cover	1
103	16680-Z010110-0001	Fuel Tank Oil Outlet Subassembly	1
104	13501-Z080110-0000	Flywheel Nut, M16 x 1.5, Blue White Zinc	1
105	28002-Z100210-0000	Starter Pulley, Blue White Zinc	1
106	19352-Z100120-0000	Impeller	1
107	13510-Z520110-0000	Flywheel Subassembly	1
108	30400-Z090210-0001	Ignition Coil	1
109	90001-0628-01	Hexagon Flange Bolt, M6 x 28, Blue White Zinc	2
110	30423-Z520120-0000	Ignition Coil Stop Engine Wire	1
111	16520-Z520130-0000	Throttle Control Assembly	1
112	16015-Z050110-VG01	Throttle Handle Rubber Sleeve	1
113	16012-Z080110-0000	Throttle Valve Returning Spring	1
114	16062-Z100110-0000	Governor Rod, Blue White Zinc	1
115	90412-Z080210-0000	Washer, Ø8.4 x Ø19.5 x 0.8	1
116	16061-Z100110-0000	Governor Arm	1
117	90682-Z100210-0001	Oil Seal, Ø8 x Ø14 x 4	1
118	90501-Z010110-0000	Pin, Blue White Zinc	1
119	16063-Z520210-0000	Spring, Governor, Blue White Zinc	1
120	16072-Z010110-0000	Governor Support Bolt, M6 x 21, Blue White Zinc	1
121	16070-Z100120-0000	Governor Support Subassembly, Blue White Zinc	1
122	16161-Z520110-0000	Main Jet, Standard	1
	16161-Z520210-0000	Main Jet, Altitude 3000-6000 feet	/
	16161-Z520310-0000	Main Jet, Altitude 6000-8000 feet	/
123	16112-Z080110-0000	Seal Ring, Float	1

#	Part Number	Description	Qty.
124	90681-Z010110-0000	Seal Ring	1
125	15011-Z520110-0000	Oil Dipstick	1
126	90107-4812-51	Self-Tapping Screw, ST4.8 x 12, Blue White Zinc	1
127	15004-Z330110-0000	Oil Dipstick Cap	1
128	15020-Z520110-0000	Oil Filling Tube	1
129	90524-Z100110-0000	Woodruff Key	1
130	12111-Z100110-0000	Inlet Valve	1
131	12121-Z100110-0000	Exhaust Valve	1
132	35552-Z330110-0000	Start Switch, Key	1
133	18160-Z520110-0000	Muffler Body	1
134	18130-Z520110-0000	Muffler Cover	1

SPECIFICATIONS

TROUBLESHOOTING

Problem	Possible Cause	Remedy
Engine fails to start.	Engine flooded.	Repeat start attempts with throttle choke OFF.
	Water in fuel.	Drain tank and refill with fresh fuel.
	Other.	Check carefully the start procedure according to this manual.
Engine starts hard or runs poorly.	Spark plug issues.	Replace the spark plug.
	Fuel cap ventilation is blocked.	Clear the ventilation.
Auger does not rotate.	Foreign material caught in system.	Clean.
	Auger drive belt slipping.	Adjust the belt and wire.
	Auger drive belt broken.	Replace the belt.
	Auger control cable is out of adjustment.	See ADJUSTING AUGER CONTROL CABLE section.
Auger does not stop when the lever is released.	Auger drive belt is out of adjustment.	Adjust the belt.
	Auger drive guide is out of adjustment.	Adjust the guide.
	Auger control cable is out of adjustment.	See ADJUSTING AUGER CONTROL CABLE section.
Snowblower veers to one side.	Tire pressure not equal.	Adjust the tire pressure.
	Wheel spring lock pin is inserted on one side.	Check the wheel locks.
	Shoes are mounted unevenly.	Adjust shoes.
	Scraper blade uneven.	Adjust scraper blade and shoes.
Snowblower does not drive.	Drive cable out of adjustment.	Adjust drive cable. See ADJUSTING SELF-DRIVE CONTROL HANDLE CABLE section.
	Auger drive belt worn/broken.	Replace traction drive belt. See REPLACE AUGER DRIVE BELT section.
	Friction disc worn out.	Repair or replace friction disc. See REPAIR OR REPLACE FRICTION DISC section.

**WARNING**

Before performing any maintenance or cleaning work, always stop engine, disconnect spark plug cable and wait until the auger has come to a standstill.

**CAUTION**

Faults which can not be rectified with the aid of this table may be rectified by a specialty company only (customer service centre).

2-YEAR LIMITED WARRANTY

This CERTIFIED™ product is guaranteed for a period of 2 years from the date of original retail purchase against defects in workmanship and materials.

Subject to the conditions and limitations described below, this product, if returned to us with proof of purchase within the stated warranty period and if covered under this warranty, will be repaired or replaced (with the same model, or one of equal value or specification), at our option. We will bear the cost of any repair or replacement and any costs of labour relating thereto.

These warranties are subject to the following conditions and limitations:

- a. a bill of sale verifying the purchase and purchase date must be provided;
- b. this warranty will not apply to any product or part thereof which is worn or broken or which has become inoperative due to abuse, misuse, accidental damage, neglect or lack of proper installation, operation or maintenance (as outlined in the applicable owner's manual or operating instructions) or which is being used for industrial, professional, commercial or rental purposes;
- c. this warranty will not apply to normal wear and tear or to expendable parts or accessories that may be supplied with the product that are expected to become inoperative or unusable after a reasonable period of use;
- d. this warranty will not apply to routine maintenance and consumable items such as, but not limited to, fuel, lubricants, blades, belts, bits, fluids, tune-ups or adjustments;
- e. this warranty will not apply where damage is caused by repairs made or attempted by others (i.e. persons not authorized by the manufacturer);
- f. this warranty will not apply to any product that was sold to the original purchaser as a reconditioned or refurbished product (unless otherwise specified in writing);
- g. this warranty will not apply to any product or part thereof if any part from another manufacturer is installed therein or any repairs or alterations have been made or attempted by unauthorized persons;
- h. this warranty will not apply to normal deterioration of the exterior finish, such as, but not limited to, scratches, dents, paint chips, or to any corrosion or discolouring by heat, abrasive and chemical cleaners; and
- i. this warranty will not apply to component parts sold by and identified as the product of another company, which shall be covered under the product manufacturer's warranty, if any.

ADDITIONAL LIMITATIONS

This warranty applies only to the original purchaser and may not be transferred. Neither the retailer nor the manufacturer shall be liable for any other expense, loss or damage, including, without limitation, any indirect, incidental, consequential or exemplary damages arising in connection with the sale, use or inability to use this product.

NOTICE TO CONSUMER

This warranty gives you specific legal rights, and you may have other rights, which may vary from province to province. The provisions contained in this warranty are not intended to limit, modify, take away from, disclaim or exclude any statutory warranties set forth in any applicable provincial or federal legislation.

Made in China

Imported by

Trileaf Distribution Toronto, Canada M4S 2B8