

CERTIFIED™/MC

model number 060-3740-6 | Contact us: 1-844-428-7277

24" (61 CM) 2-STAGE SNOWBLOWER

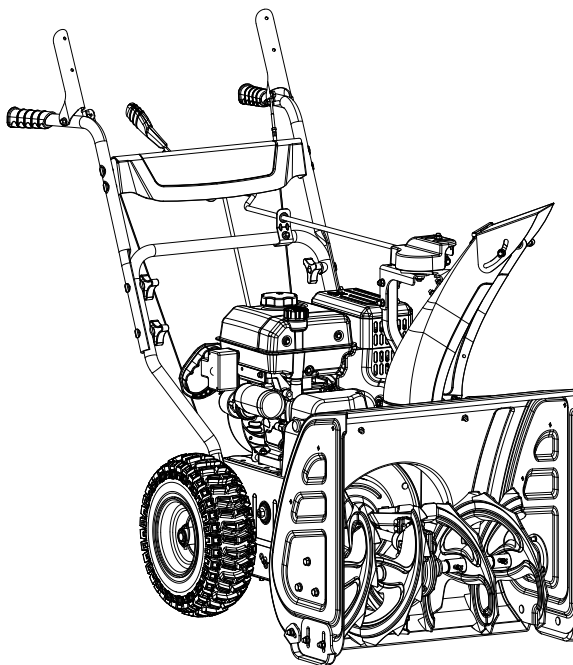

IMPORTANT:

Please read this manual carefully before operating this snowblower and save it for reference.

INSTRUCTION MANUAL



WARNING

MACHINE IS WITHOUT ENGINE OIL, PROPERLY FILL ENGINE OIL PRIOR TO USE TO PREVENT ENGINE DAMAGE.

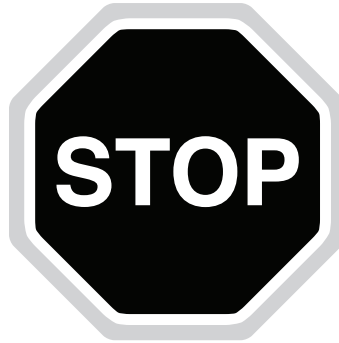

For problems or questions, **DO NOT RETURN TO STORE**. Please contact one of our **Customer Service Agents** who would be happy to assist you.



For Customer Assistance Please Call:
1.844.428.7277

Read and understand this instruction manual thoroughly before using the product. It contains important information for your safety as well as operating and maintenance advice.

Keep this instruction manual for future use. Should this product be passed on to a third party, this instruction manual must be included.

Contact Information.....2

Table of Contents3

Safety Information4

 General Safety4

 Preparation For Use4

 Safe Handling of Gasoline4

 Operation5

 Clearing a Clogged Discharge Chute6

 Maintenance and Storage6

 Safety Definitions7

 Safety Symbols.....7

 Operation Symbols8

Features..... 10

 Know Your Snowblower.....10

 Engine.....10

Assembly.....12

 Unpacking12

 Additional Parts.....12

 Tools Required.....12

 Assembly Parts.....12

 Assembly.....15

 Wheels and Shoes15

 Handle15

 Speed Control Connecting Lever16

 Self-Drive Control Wire And Auger Control Wire16

 Snow Discharge Support17

 Snow Discharge Chute.....17

 Discharge Chute Rotation Lever18

Operation 19

 Before Operation.....19

 Check the General Condition.....19

 Check the Engine19

 Operation19

 Starting the Engine19

 Stopping the Engine21

 Operation at High Altitude21

 Operating the Machine21

 Control Levers.....21

 Drive System.....22

 Adjusting the Snow Discharge Direction and Height.....22

 Adjusting the Snow Shoes.....23

 To Adjust the Shoes.....23

 After Use.....24

Maintenance24

 Servicing24

 Safety Precautions.....24

Maintenance25

 Regular Service Periods.....25

 Refueling.....26

 Adding Fuel26

 Check Engine Oil Level26

 Oil Change27

 Replacing Shear Pins28

 Adjusting Self-Drive Control Handle Cable29

 Adjusting Auger Control Cable.....29

 Replace Auger Drive Belt Without Splitting the Snowblower Body (Option 1).....30

 Replace Auger Drive Belt – Splitting the Snowblower Body (Option 2).....34

 Repair or Replace Friction Disc36

 Lubrication.....38

 Long-Term Storage.....38

 Transporting.....38

Specifications 39

 Specifications39

 Snowblower Specifications.....39

 Engine Specifications.....39

 Oil Specifications39

 Fuel Specifications.....39

 Parts List Diagram40

 Parts List.....41

 Engine Parts List Diagram.....46

 Parts List.....47

Troubleshooting50

 Troubleshooting50

Warranty Information.....51

 2-Year Limited Warranty.....51

 Additional Limitations.....52

 Notice To Consumer.....52

SAVE THESE INSTRUCTIONS

This manual contains important safety and operating instructions. Read all instructions and follow them with use of this product.

GENERAL SAFETY

1. Read the operating and service instruction manual carefully. Be thoroughly familiar with the controls and the proper use of the equipment. Know how to stop the unit and disengage the controls quickly.
2. Never allow children under 16 years old to operate the equipment. Never allow adults to operate the equipment without proper instruction.
3. Thrown objects can cause serious injury. Keep the area of operation clear of all persons, particularly small children, and pets. Plan your snow discharge pattern to prevent throwing material toward cars, structures, roads and people.
4. Exercise caution to avoid slipping or falling, especially when operating in reverse.
5. Keep in mind that the operator or user is responsible for accidents or hazards occurring to other people or their property.
6. Never use the snowblower under the influence of alcohol or medication, or if you are tired or ill.

PREPARATION FOR USE

1. Thoroughly inspect the area where the equipment is to be used and remove all doormats, sleds, boards, wires, and other foreign objects.
2. Disengage all clutch handles before starting the motor.
3. Do not operate the equipment without wearing adequate winter garments. Wear footwear which will improve footing on slippery surfaces.
4. Adjust the auger housing height to clear gravel or crushed rock surface.

5. Never attempt to make any adjustments while the engine is running (except where specifically recommended in the manual).
6. Let engine and machine adjust to outdoor temperatures before starting to clear snow.
7. The operation of any powered machine can result in foreign objects being thrown into the eyes. Always wear safety glasses or eye shields during operation, or while performing an adjustment or repair.
8. Inspect the auger and impeller before starting to ensure that there is no ice build up.

SAFE HANDLING OF GASOLINE

To avoid severe injury or property damage use high levels of care while handling gasoline. Gasoline is an extremely flammable substance and the vapours are explosive. Serious personal injury can occur when gasoline is spilled on yourself or your clothes, which can ignite. If you come into contact with gasoline, wash affected areas of skin and change clothing immediately.

1. Use only an approved gasoline container.
2. Extinguish all cigarettes, cigars, pipes and other sources of ignition prior to working with or near gasoline.
3. Never refuel machine within closed spaces.
4. Never remove gas cap or add fuel while the engine is hot or running.
5. Allow engine to cool at least two minutes before refueling.
6. Do not over fill fuel tank. Keep fuel level at least ½ in. (1.27 cm) below bottom of filler neck to provide space for fuel expansion.
7. Replace gasoline cap and tighten securely.

8. If gasoline is spilled, wipe it off the engine and equipment. Move machine to another area. Wait 5 minutes before starting the engine.
 9. Never store the machine or fuel container inside where there is an open flame, spark or pilot light (e.g. furnace, water heater, space heater, clothes dryer etc.).
 10. Allow machine to cool at least 5 minutes before storing.
 11. Never fill containers inside a vehicle or on a truck or trailer bed with a plastic liner. Always place containers on the ground away from your vehicle before filling.
 12. If possible, remove gas-powered equipment from the truck or trailer and refuel it on the ground. If this is not possible, then refuel such equipment on a trailer with a portable container, rather than from a gasoline dispenser nozzle.
 13. Keep the nozzle in contact with the rim of the fuel tank or container opening at all times until fueling is complete. Do not use gas cans with nozzle lock-open devices.
4. If the unit should start to vibrate abnormally, stop the engine and check immediately for the cause. Vibration is generally a warning of trouble. Vibration typically indicates a mechanical problem has occurred.
 5. Stop the engine whenever you leave the operating position, before unclogging the auger housing or discharge guide, and when making any repairs, adjustments, or inspections.
 6. Before cleaning, inspecting or repairing any parts of the snowblower ensure the auger has stopped moving. Disconnect the spark plug wire and keep it away from the plug to prevent accidental starting.
 7. Before leaving the machine unattended, disengage all control levers, stop the engine and remove the safety key.
 8. Do not run the engine indoors. Exhaust fumes are dangerous.
 9. Do not clear snow across the face of slopes. Exercise extreme caution when changing direction on slopes. Do not attempt to clear steep slopes.

OPERATION

1. Do not put hands or feet near or under rotating parts. Keep clear of the discharge opening at all times.
 2. Exercise extreme caution when operating on or crossing gravel drives, walks, or roads. Stay alert for hidden hazards or traffic.
 3. After striking a foreign object, stop the engine, remove the spark plug, thoroughly inspect the snowblower for any damage, and repair the damage before restarting and operating the snowblower.
10. Never operate the snowblower without proper guards, plates or other safety protective devices in place.
 11. Never operate the snowblower near glass enclosures, automobiles, window wells, etc., without proper adjustment of the snow discharge angle. Keep children and pets away.
 12. Do not overload the machine capacity by attempting to clear snow at too fast a rate.
 13. Never operate the machine at high transport speeds on slippery surfaces. Use care when reversing.

14. Never direct discharge at bystanders or allow anyone in front of the unit.
15. Disengage power to the impeller when snowblower is transported or not in use.
16. Use only attachments and accessories approved by the manufacturer of snowblower.
17. Never operate the snowblower without good visibility or light. Always be sure of your footing, and keep a firm hold on the handles. Walk; never run.
18. Take all possible precautions when leaving the machine unattended. Disconnect the power take-off and stop the engine.
19. Keep all nuts, bolts and screws tight to be sure the equipment is in safe working condition;
20. Replace worn or damaged parts for safety; Use only genuine replacement parts and accessories.
21. This snowblower is not intended for use by persons (including children) with reduced physical, sensory or mental capabilities, or lack of experience and knowledge, unless they have been given supervision or instruction concerning use of the appliance by a person responsible for their safety.
22. Be careful while working on the machine or clearing a blockage in the auger or impeller to ensure that fingers and hands do not become crushed or cut.
23. Do not touch hot engine components like the muffler, muffler guard or engine block during operation of the snowblower as they will cause burns.
24. Should the unit stop discharging snow

for any reason, release the controls to stop and inspect for any lodged items or damaged parts in the auger housing.

CLEARING A CLOGGED DISCHARGE CHUTE

Hand contact with the rotating impeller inside the discharge chute is the most common cause of injury associated with snowblowers. Never use your hand to clean out the discharge chute or auger assembly.

To clear the chute:

1. **SHUT THE ENGINE OFF!**
2. Wait 10 seconds to be sure the impeller blades have stopped rotating.
3. Always use a clean-out tool. **DO NOT** use your hands.

MAINTENANCE AND STORAGE

1. Check shear bolts, engine mounted bolts, etc., at frequent intervals for proper tightness to sure the equipment is in safe, working condition.
2. Never store the machine with fuel in the fuel tank inside a building where ignition sources are present such as hot water heaters, space heaters, clothes dryers or any open flame sources. Allow the engine to cool before storing in any enclosure.
3. Always refer to owner's guide instructions for important details if the snowblower is to be stored for an extended period.
4. Maintain or replace safety and instructions labels, as necessary.
5. Run the snowblower for one minute to clear out packed snow and ice to prevent freeze-up during storage.

SAFETY DEFINITIONS

⚠ DANGER
DANGER indicates a hazardous situation which, if not avoided, will result in death or serious injury.



⚠ WARNING
WARNING indicates a hazardous situation which, if not avoided, could result in death or serious injury.







⚠ CAUTION
CAUTION indicates a hazardous situation which, if not avoided, could result in minor or moderate injury.





NOTICE
NOTICE is used to address practices not related to physical injury.

SAFETY SYMBOLS

Some of the following symbols may be used on this product. Please study them and learn their meaning. Proper interpretation of these symbols will allow you to safely operate the product.









| Symbol | Name | Designation/Explanation |
|---|-----------------------------|--|
|  | Read the Instruction Manual | To reduce the risk of injury, user must read and understand the instruction manual before using this product. |
|  | Eye and Ear Protection | Always wear safety goggles or safety glasses with side shields, and as necessary a full face-shield as well as full ear protection when operating this product. Always wear eye protection with side shields marked to comply with ANSI Z87.1. |

| Symbol | Name | Designation/Explanation |
|---|-----------------------|--|
|  | Safety Alert | This machine was built to be operated according to the safe operation practices in this manual. As with any type of power equipment, carelessness or error on the part of the operator can result in serious injury. This machine is capable of amputating fingers, hands, toes and feet and throwing foreign objects. Failure to observe the safety instructions could result in serious injury or death. |
|  | Electric Shock | Failure to use the starter in dry conditions and to observe safe practices can result in electric shock. |
|  | Risk of Fire | Fuel and its vapours are extremely flammable and explosive. Fire can cause severe burns or death. Do not add fuel while the product is operating or still hot. |
|  | Toxic Fumes | The engine exhaust from this product contains chemicals known to cause cancer, birth defects and other reproductive harm. |
|  | Risk of Asphyxiation | This engine emits carbon monoxide, an odourless, colourless poison gas. Breathing carbon monoxide can cause nausea, fainting or death. Use only in a well-ventilated area. |
|  | Thrown Objects | This machine may pick up and throw objects which can cause serious personal injury. |
|  | Always Use Chute Tool | Never use your hands to clear a clogged chute assembly. Shut OFF engine and remain behind handles until all moving parts have stopped before unclogging. |

| Symbol | Name | Designation/Explanation |
|---|-----------------|--|
|  | Hot Surface | Exhaust gases, muffler and engine components are extremely HOT and cause burns. |
|  | Risk of Fire | Fuel and its vapours are extremely flammable and explosive. Fire can cause severe burns or death. Do not add fuel while the product is operating or still hot. |
|  | Rotating Auger | DANGER: Avoid injury from rotating auger - keep feet away. |
|  | Rotating Blades | Never put your hand in the chute. Contact with rotating parts can amputate fingers and hands. |

OPERATION SYMBOLS

Some of the following symbols may be used on this product. Please study them and learn their meaning. Proper interpretation of these symbols will allow you to safely operate the product.

| Symbol | Name | Designation/Explanation |
|---|----------------------|---|
|  | Engine Start | Follow steps to start engine. |
|  | Check Oil Level | Recommended oil is 0W-30. The engine can be seriously damaged without oil. Always check the oil level before using. The machine must be resting firmly on level ground when checking. |
|  | Check Fuel Level | Use clean, fresh, regular unleaded gasoline with a minimum octane rating of 85 and an ethanol content of less than 10% by volume. |
|  | Minimum Octane | Use clean, fresh, regular unleaded gasoline with a minimum octane rating of 85 and an ethanol content of less than 10% by volume. |
|  | Fuel Valve: ON | Move the fuel valve lever to the on position. |
|  | Choke: ON | To start a cold engine, move the choke lever to the choke position. |
|  | Throttle: Full Speed | Move the throttle lever to full speed to start the engine. |
|  | Throttle: Low Speed | Lowers the speed of the engine. |

| Symbol | Name | Designation/Explanation |
|--|-------------------|--|
|  | Insert Engine Key | Make sure the engine safety key is inserted into the key hole. |
|  | Cold Prime | To start a cold engine, prime 3-5 times. |
|  | Warm Prime | To start a warm engine, DO NOT prime. |
|  | Recoil Start | Pull the recoil starter grip to start manually. |
|  | Choke: OFF | When the engine starts, move the choke to run position. |
|  | Stop | Follow steps to stop. |
|  | Fuel Valve: OFF | Move the fuel valve lever to the OFF position. |
|  | Remove Engine Key | Remove the engine key. |

SAFETY INFORMATION

KNOW YOUR SNOWBLOWER

- 1 Self-Drive Control Handle
- 2 Upper Handles
- 3 Speed Control Connecting Lever
- 4 Handle Locking Knobs
- 5 Lower Handle
- 6 Wheels
- 7 Auger Housing
- 8 Adjustable Skid Shoes
- 9 Auger
- 10 Impeller
- 11 Clean Out Tool
- 12 Discharge Chute
- 13 Discharge Deflector
- 14 Discharge Chute Rotation Lever
- 15 Discharge Chute Lever Guide
- 16 Auger Control Handle
- 17 Speed Adjusting Handle
- 18 Shear Pin and Clip Storage

ENGINE

- 1 Key (safety lock out)
- 2 Primer Bulb
- 3 Throttle Lever
- 4 Choke Lever
- 5 Fuel Valve (On/Off)
- 6 Oil Drain Plug
- 7 Recoil Starter Grip
- 8 Electric Start Button
- 9 Fuel Cap
- 10 Oil Fill and Level Check Cap

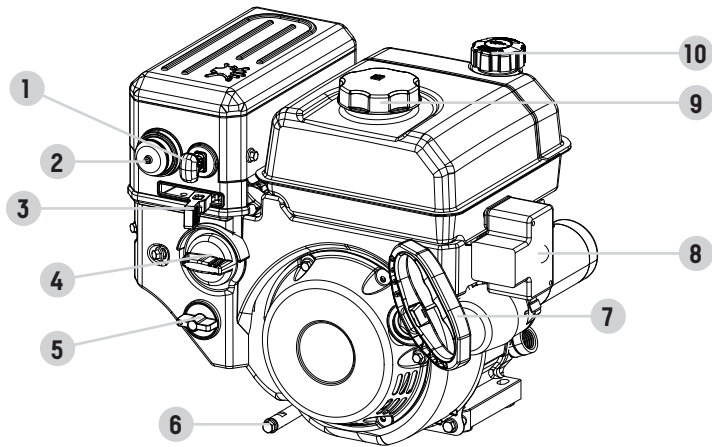
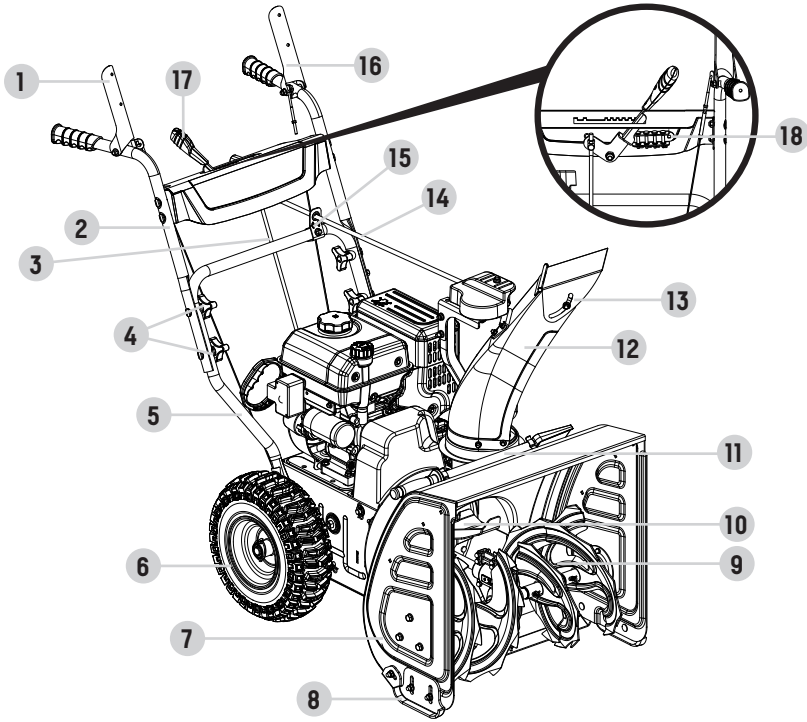

FEATURES

UNPACKING

1. Set the shipping carton on a solid, flat surface.
2. Remove everything from the carton except the snowblower base — including upper and lower handles, wheels, connecting levers, chute, hardware, etc. Make sure all the assembly parts are included before you start.
3. Lift the top half of the box off and the base should be clear to start assembly.
4. Cut down the bottom carton to allow a flat surface area to install the assembly parts without scratching parts or cutting tires. Alternatively, with team lift help, lift the base of the snowblower out of the carton and place it on a flattened carton to start assembly.
5. Now you are ready for assembly.



ADDITIONAL PARTS





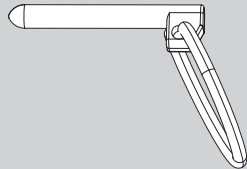
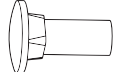

| Part | Part Qty. | Usage |
|-----------------------|-----------|------------|
| Shear Pin (for auger) | 4 | Spare part |
| Clip (for auger) | 4 | Spare part |
| Starter Electric Cord | 1 | Accessory |

TOOLS REQUIRED

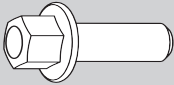
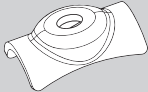
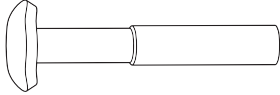
| Tool | Size |
|---------------------------------------|----------|
| Wrench (included) | 10, 12 |
| Cross-head Screwdriver (not included) | Standard |

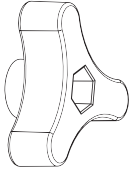

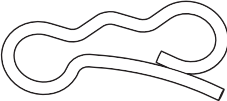
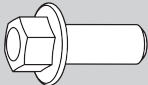

ASSEMBLY PARTS

| Part | Part Qty. | Hardware Needed | Hardware Qty. | Hardware Reference | Tool(s) Needed |
|--------|-----------|---|---------------|--|----------------|
| Wheels | 2 | Spring lock pin (1-3) | 2 |  | N/A |
| Shoes | 2 | M8×20 Carriage bolt (1-4) | 4 |  | Size 12 Wrench |
| | | M8 All-metal hexagon flange locking nut (1-5) | 4 |  | |

| Part | Part Qty. | Hardware Needed | Hardware Qty. | Hardware Reference | Tool(s) Needed |
|--------------------------------|-----------|---|---------------|---|----------------|
| Lower handle | 1 | M8×45 Hexagon flange bolt (2-2) | 2 |  | Size 12 Wrench |
| | 1 | M8×20 Hexagon flange bolt (2-3) | 2 |  | Size 12 Wrench |
| | | Shaped washer (2-4) | 2 |  | N/A |
| Upper handle | 1 | M8×52 Flat head bolts (2-5) | 4 |  | N/A |
| | | Curved washer (2-6) | 4 |  | N/A |
| | | Locking knob V (2-7) | 4 |  | N/A |
| Discharge chute bracket | 1 | M8×45 Hexagon flange bolt (2-8) | 1 |  | Size 12 Wrench |
| | | M8 All-metal hexagon flange lock nut (2-9) | 1 |  | Size 12 Wrench |
| Speed control connecting lever | 1 | Clip (3-1) | 2 |  | N/A |
| Snow discharge support | 1 | M6×20 Hexagon flange bolt (preassembled) (4-1) | 2 |  | Size 10 Wrench |
| | | M6 All-metal hexagon flange lock nut (preassembled) (4-2) | 3 |  | Size 10 Wrench |

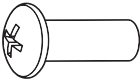
ASSEMBLY

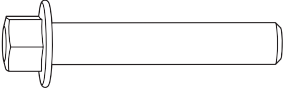
ASSEMBLY

| Part | Part Qty. | Hardware Needed | Hardware Qty. | Hardware Reference | Tool(s) Needed |
|---------------------------|-----------|---|---------------|--|------------------------|
| Snow discharge chute | 1 | M6×16 Screw (preassembled) (5-1) | 3 |  | Cross-head Screwdriver |
| | | M6 All-metal hexagon flange lock nut (preassembled) (5-2) | 3 |  | Size 10 Wrench |
| | | M8×45 Hexagon flange bolt (preassembled) (5-3) | 2 |  | Size 12 Wrench |
| | | M8 All-metal hexagon flange lock nut (preassembled) (5-4) | 2 |  | Size 12 Wrench |
| Discharge adjusting lever | 1 | R pin (preassembled) (5-5) | 1 |  | N/A |
| Auger control handle | 1 | Auger control wire assembly | | | N/A |
| Self-drive control handle | 1 | Self-drive control wire assembly | | | N/A |

ASSEMBLY

WHEELS AND SHOES

1. Slide the left wheel (1-1) onto axle (1-2) as the arrow shows. Tread pattern should face forward. Place axle pin (1-3) into wheel. The axle has a centre hole to attach the wheel to the axle (which connects to the drive train). Once inserted, fold around axle to hold in place (Fig. 1).
2. Repeat on right side. Tread pattern should face forward.

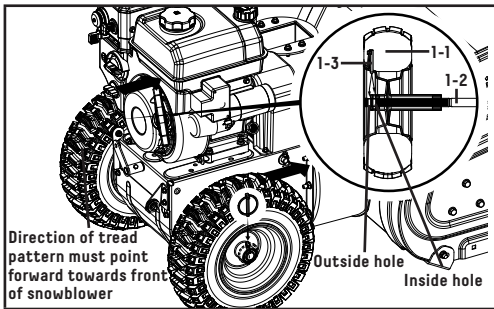

Figure 1

3. Attach adjustable skid shoes to auger housing. Insert bolts (1-4) through the auger housing then through the shoe (Fig. 2). Tighten nuts (1-5) tightly (Fig. 2). Do not overtighten. The shoe is not reversible. See "Adjusting the Snow Shoes" section.

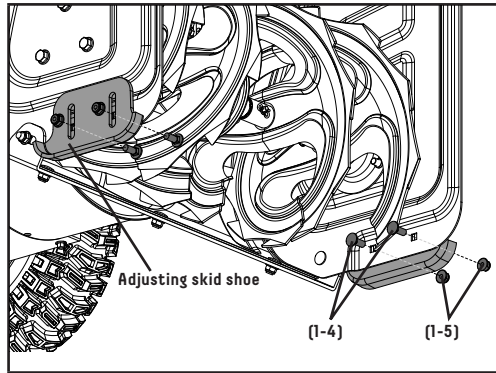

Figure 2

HANDLE

1. Attach the lower handle (2-1) onto the unit body with bolts (2-2, 2-3) and washers (2-4) (Fig. 3). Repeat on the other side. See Fig. 5 for proper discharge chute bracket mounting hole orientation.

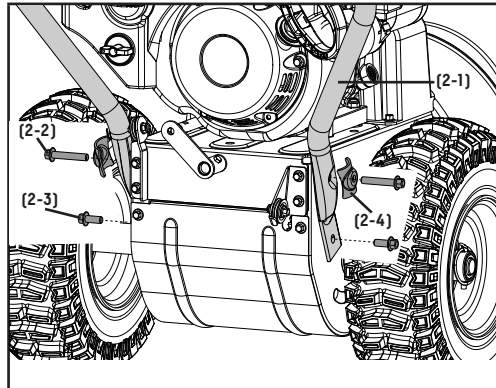

Figure 3

NOTICE:

Only the left axle has two holes, and the axle pin can be removed and repositioned. If the wheel is slid further in on the axle with the pin inserted into the outside hole of the axle, the machine will move freely without the engine on. If the pin is inserted into the inside hole of the axle, the machine will only move when the drive control is engaged when the engine is on.

It is optional to slide one wheel past the pin hole in the axle and to place the locking pin into the axle outside the wheel without locking it into the drive axle. This creates a pivot wheel that allows the operator to easily turn the snowblower during use by using the "free wheel" as a pivot point. Though this makes turning easier, it decreases drive wheel traction by 50%.

2. Connect the upper handle and lower handle with bolts (2-5), washers (2-6) and locking knobs (2-7) (Fig. 4).

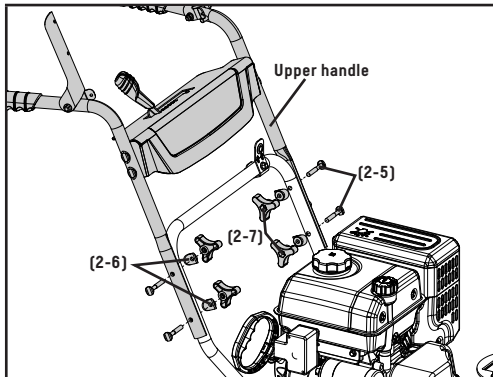

Figure 4

3. Connect discharge chute guide to lower handle with 1 bolt (2-8), and 1 lock nut (2-9) (Fig. 5).

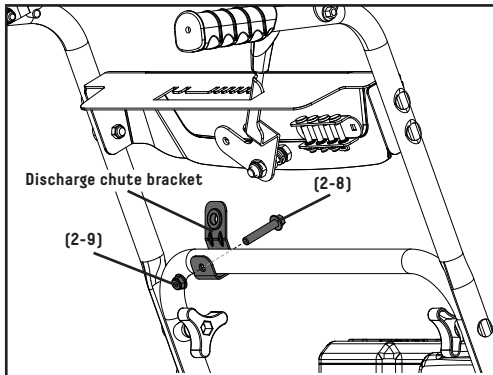

Figure 5

SPEED CONTROL CONNECTING LEVER

1. Connect the connecting lever and connecting base with clip (3-1).
2. Connect the connecting lever and speed adjusting handle with clip (Fig. 6).

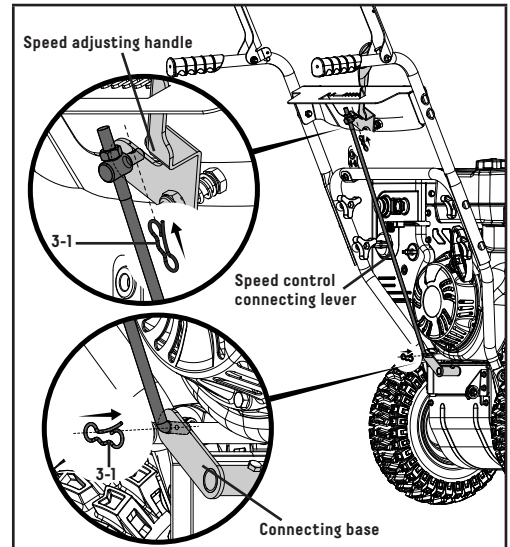

Figure 6

SELF-DRIVE CONTROL WIRE AND AUGER CONTROL WIRE

1. The auger control wire includes part A and part B (Fig. 7).
2. Lift the auger control handle to the upper position (Fig. 7).
3. Hook part A into the auger control handle (Fig. 7).

NOTICE:

Discharge chute bracket should be placed forward as shown (for correct placement). Do not overtighten.

4. Connect part A and part B of the auger control wire to get a natural tension station for the wire. (Fig. 7)
5. Hook the self-control wire into the self-drive handle in the same way.

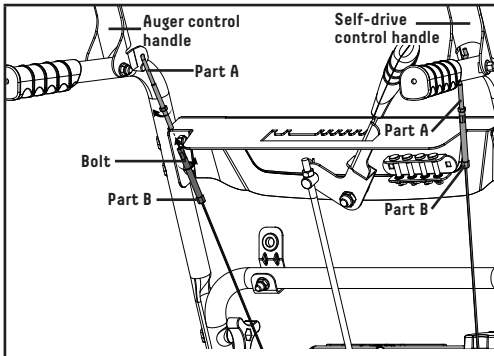

Figure 7

SNOW DISCHARGE SUPPORT

1. Locate the position for assembly (Fig. 8).
2. Remove the bolts (4-1) (Fig. 8) and nuts (4-2) (Fig. 8) from the main body as shown (Fig. 8). Set aside for next step.
3. Align snow discharge support with the main body.
4. Attach the snow discharge support on the main body with bolts (4-1) (Fig. 8).
5. Tighten all nuts (4-2) as shown (Fig. 8). Do not overtighten.

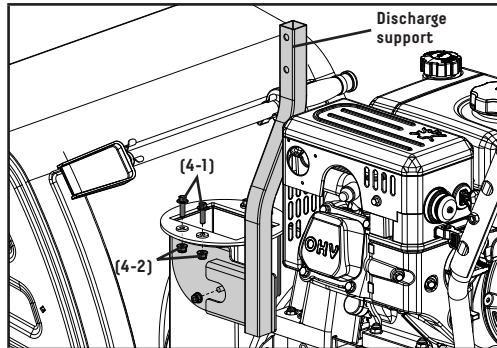

Figure 8

SNOW DISCHARGE CHUTE

1. Remove the bolts (5-1) (Fig. 9A) and nuts (5-2) (Fig. 9A) on the snow discharge chute (Fig. 9A). Hold for later step.
2. Tighten snow discharge chute and the component shown in Fig. 9A using three bolts (5-1) (Fig. 9A) and three nuts (5-2) (Fig. 9A). Be careful not to deform the plastic.
3. Remove the bolts (5-3) and nuts (5-4) on the snow discharge support. Put the snow discharge chute on the base of unit's body. Attach the snow discharge support using bolts (5-3) and nuts (5-4) (Fig. 9B).

NOTICE:

In the process of operation, if the auger or drive control handle is too loose, screw the bolt (Fig. 7) of part A to get a natural tension station for the wire.

Check the slack of the tension and adjust accordingly. You want to make sure that the tension on the lower side of the snowblower has 1/4-3/8" (6.4-9.5 mm) of movement. If the slack is greater than 5/8" (16 mm), please adjust. Proper tension is important because you will want your snowblower to move forward properly in heavy snowfalls.

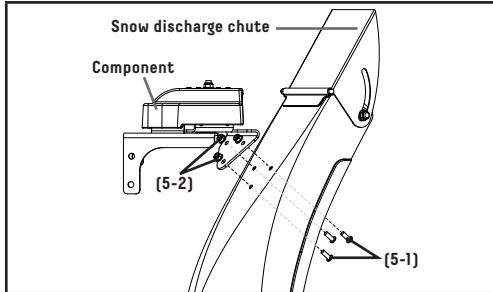

Figure 9A

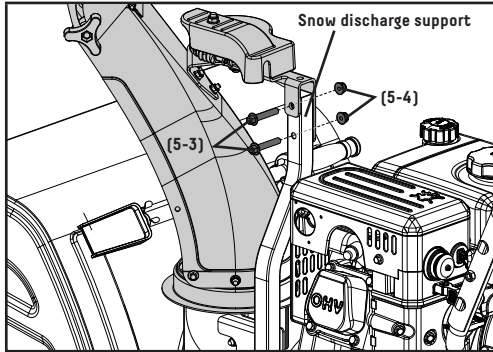

Figure 9B

DISCHARGE CHUTE ROTATION LEVER

1. Remove the R-clip from the gear as applicable. Set aside for a later step. It may be preinstalled by the factory.
2. Insert the lever through the discharge chute bracket on the lower handle, and then into the hole of the gear (Fig. 10A).
3. Align the lever and the gear, and then connect the R pin (5-5). (Fig. 10B)
4. Check the snow discharge chute by turning it fully in both directions. The discharge chute should rotate freely.

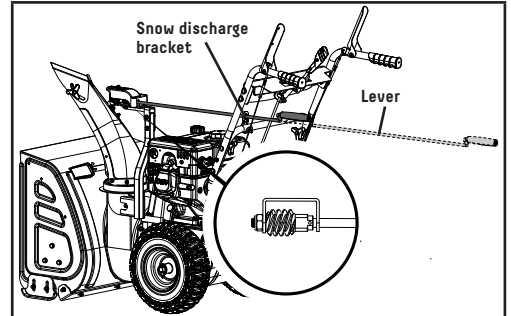

Figure 10A

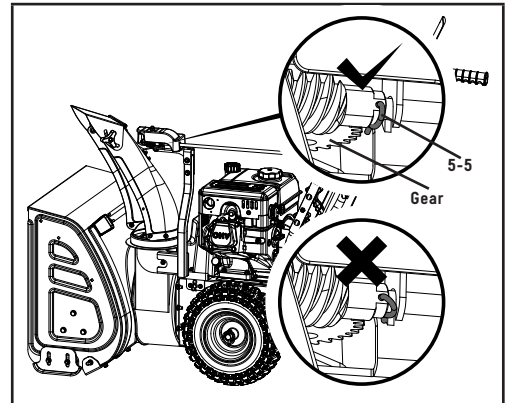

Figure 10B



WARNING

Ensure the R pin is positioned as shown in Fig. 10B.

BEFORE OPERATION

CHECK THE GENERAL CONDITION

- Look around and underneath the engine for signs of oil or gasoline leaks.
- Remove any excessive dirt or debris, especially around the muffler and recoil starter.
- Look for signs of damage.
- Check that all shields and covers are in place, and all nuts, bolts, and screws are tightened.

CHECK THE ENGINE

1. There is no fuel or oil in the engine. Fill with fuel and add 0W-30 prior to first use.
2. Check the fuel level (see adding fuel section).
3. Check the oil level (see check engine oil level section).
4. See refueling section for more details.

OPERATION

STARTING THE ENGINE

Read instructions carefully.

1. Make sure the engine safety key is inserted into the key hole (Fig. 11A).
2. Move the fuel valve lever to the on position (Fig. 11A).
3. Move choke lever depending on unit's temperature:
 - a. To start a cold engine, move the choke lever to the choke position (Fig. 11A).
 - b. To start a warm engine, leave the choke lever to the run position (Fig. 11B).
4. Move the throttle lever to full speed to start the engine (Fig. 11B).
5. Use primer control depending on unit's temperature (Fig. 11B):
 - a. To start a cold engine, prime 3-5 times.
 - b. To start a warm engine, do not prime.
6. Stand back and to the right of the unit, pull the starter grip lightly until you feel resistance then pull briskly. Return the starter grip gently (Fig. 11C).

NOTICE:

The engine can be seriously damaged without oil. Always check the oil level before using. The machine must stand on level ground when checking.

Engine key and throttle lever plastic piece need to be attached before first use. These parts may be attached to the recoil starter grip. Please remove the key and throttle lever from the recoil starter grip and attach/install properly.



WARNING

Never start the engine until all the above measures under assembly have been carried out.

Never use the snowblower without first reading and understanding the instructions and all the warning and instruction stickers on the machine.

Always use protective goggles or a visor during use, maintenance and service.

7. Alternatively for electric start, plug in the supplied electrical cord into the starter. Press the electric start button and make sure that the main supply voltage is 120 V~ 60 Hz (Fig. 11D).
8. When the engine starts, move the choke to run position (Fig. 11B).

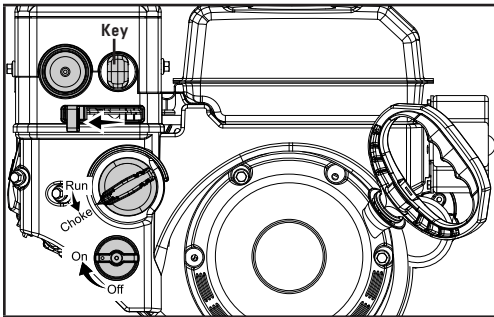

Figure 11A

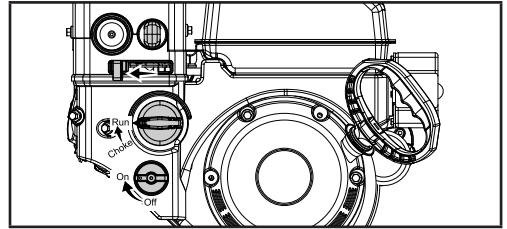

Figure 11B

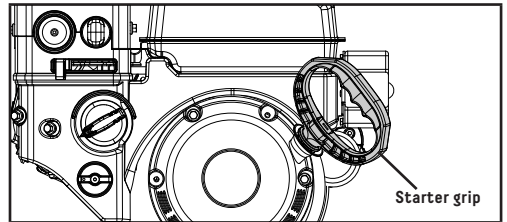

Figure 11C

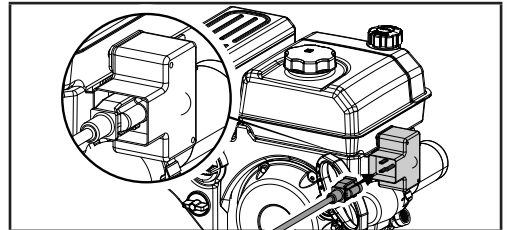

Figure 11D

**WARNING**

Gasoline is highly flammable.

Store fuel in containers specifically designed for this purpose. Refuel outdoors only, before starting the engine, and do not smoke while refueling or handling fuel. Never remove the cap of the fuel tank or add gasoline while the engine is running or when the engine is hot. If gasoline is spilled, do not attempt to start the engine but move the machine away from the area of spillage and avoid creating any source of ignition until gasoline vapours have dissipated. Replace all fuel tanks and container caps securely. Before tipping the snowblower to maintain the blade or drain oil, remove fuel from tank.

WARNING

Never fill fuel tank indoors, with engine running, or until the engine has been allowed to cool for at least 15 minutes after running.

CAUTION

To prevent damaging the electric starter, do not run it more than 10 times at intervals of 5 seconds on, then 5 seconds off. If the engine does not start after this series of attempts, allow the starter to cool for at least 40 minutes before trying to start it again. If the engine still does not start, take the engine to an authorized service centre for service. Once started, disconnect the plug from the power supply and the starter.



STOPPING THE ENGINE

To stop the engine in an emergency situation or during normal operation simply remove the engine key.

OPERATION AT HIGH ALTITUDE







The density of air at high altitude is lower than at sea level. Engine power is reduced as the air mass and air-fuel ratio decrease. Engine power will be reduced approximately 3 ½% for every 1000' (304 m) of elevation above sea level. This is a natural trend and cannot be changed by adjusting the engine. At high altitudes increased exhaust emissions can also result due to the increased enrichment of the air fuel ratio. Other high altitude issues can include hard starting, increased fuel consumption and spark plug fouling. To alleviate high altitude issues other than the natural power loss, we can provide a high altitude carburetor main jet at an additional cost.

The part number and recommended minimum altitude for the application of the high altitude carburetor main jet is listed in the following table. In order to select the correct high altitude main jet, it is necessary to identify the carburetor model. For this purpose, a code is stamped on the side of the carburetor. Select the correct high altitude jet part number corresponding to the carburetor code found on your particular carburetor.

| Carburetor Code | Main Jet | Jet Part Number | Altitude |
|--------------------|---------------|--------------------|--------------------------|
| 16100-Z1S0110-0009 | Main Jet | 16161-Z1S0110-0000 | |
| | High Altitude | 16161-Z1S0210-0000 | 914-1828 m (3000-6000') |
| | High Altitude | 16161-Z1S0310-0000 | 1828-2438 m (6000-8000') |

OPERATING THE MACHINE

CONTROL LEVERS

| | |
|--|---|
|  | Self-drive control handle. Located on the right side handle (Fig. 12). |
|  | When the snowblower has been put into gear, pushing this lever towards the handle engages the wheels. |
|  | Releasing the self-drive control handle causes the machine to stop moving. |
|  | Auger control handle. Located on the left side handle (Fig. 12). |
|  | Pushing this lever towards the handle causes the auger and impeller to activate. |
|  | Releasing the auger control handle causes the auger to stop moving. |

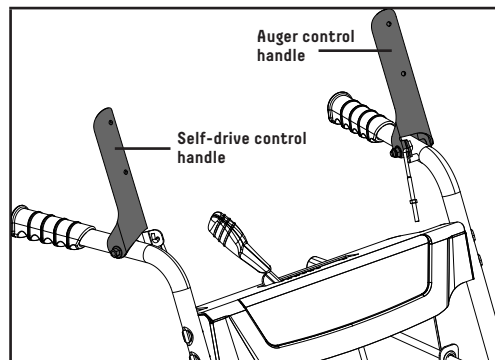

Figure 12



WARNING

Watch out for rotating auger. Keep hands, feet, hair and loose clothing away from any moving parts on the machine.

DRIVE SYSTEM

Your snowblower has 6 forward speeds and 2 reverse to regulate forward and backward motion (Fig. 13).

| | |
|--|---|
| | Forward speeds range from slowest position 1 to fastest position 6. |
| | Reverse speeds range from slowest position R1 to fastest position R2. |
| | Faster |
| | Slower |

Adjusting the self-propelled drive system:

1. Release the self-drive control handle to bring the snowblower to a stop.
2. Move the speed-control lever to the gear (either forward or reverse) that you require (Fig. 13).
3. Press the self-drive control handle to engage the drive system.

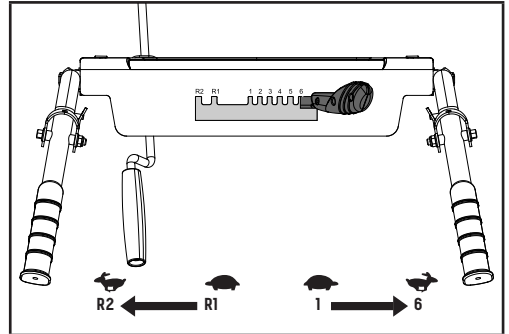

Figure 13

ADJUSTING THE SNOW DISCHARGE DIRECTION AND HEIGHT

Change discharge direction:

| | |
|--|--|
| | Turn the lever counter-clockwise – the snow discharge guide turns to the left. |
| | Turn the lever clockwise – the snow discharge guide turns to the right. |

Change discharge height:

1. Loosen the locking knob to adjust the snow discharge deflector to a suitable height (Fig. 14).
2. Adjust the snow discharge deflector from 0 – 60°.
3. Tighten the locking knob.



WARNING

If snow clogs the discharge chute do not try to remove it before:

- Releasing the auger control handle.
- Stopping the engine.
- Disconnecting the cable from the spark plug.

Do not put your hand inside the chute or auger. Use the chute clearing tool included with your snowblower.

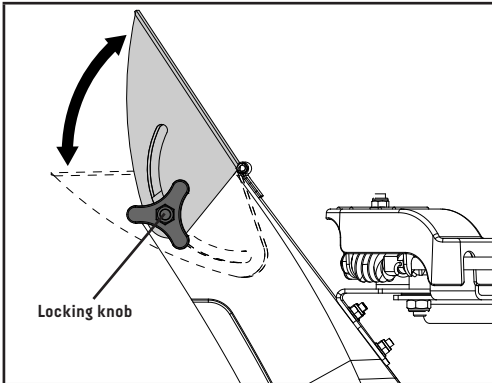
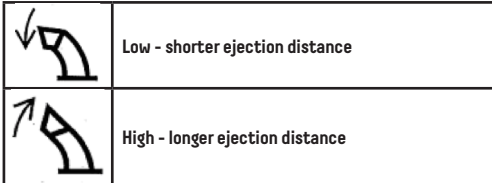

Figure 14

ADJUSTING THE SNOW SHOES

Set the height of the auger housing to suit the ground conditions (Fig. 15):

- On flat ground, e.g. asphalt, the shoes should be adjusted to about 3/16" (5 mm) (the distance from the auger to the ground).

- On uneven ground, e.g. gravel paths, the shoes should be adjusted to about 1 3/16" (30 mm) (the distance from the auger to the ground).

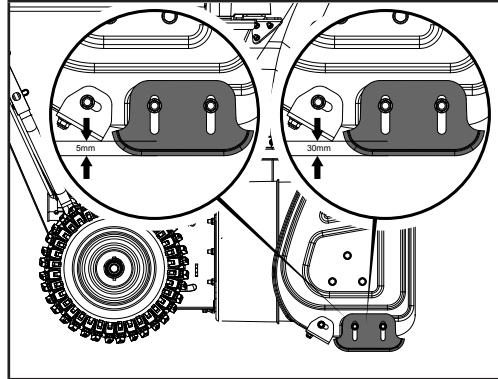

Figure 15

TO ADJUST THE SHOES

1. Loosen the nuts.
2. Move the shoes upward or downward to adjust height.
3. Tighten the nuts.



CAUTION

Always adjust the shoes so that gravel and stones are not fed into the snowblower. There is a risk for personal injury if these are thrown out at high speed.

Ensure the shoes are adjusted the same on both sides.

CAUTION

Do not at any time make any adjustments to machine without first stopping the engine and disconnecting the spark plug wire.

CAUTION

Before changing height, stop engine and disconnect spark plug cable.

AFTER USE

1. Check for loose or damaged parts. If required, change damaged parts.
2. Tighten loose screws and nuts.
3. Brush all the snow from the machine.
4. Move all the controls backwards and forwards a few times.
5. Disconnect the starting cable from the spark plug.

SERVICING**SAFETY PRECAUTIONS**

Make sure the engine is off before you begin any maintenance or repair. This will eliminate several potential hazards:

- Carbon monoxide poisoning from engine exhaust — never run the machine indoors. The exhaust fumes contain carbon monoxide, a very toxic gas.
- Burns from hot parts — let the engine cool for 30 minutes before touching hot parts.
- Injury from moving parts — read the instructions before you begin, and make sure you have the tools and skills required.

To reduce the possibility of fire or explosion, be careful when working around gasoline. Use only a nonflammable solvent, not gasoline, to clean parts. Keep cigarettes, sparks and flames away from all fuel-related parts.

**CAUTION**

Do not cover the machine while the engine and silencer are still warm.

MAINTENANCE

REGULAR SERVICE PERIODS

Perform at every indicated month or operating hour interval, whichever comes first.

| Item | Service | Each Use | Every month or 20 hrs. | Every 3 months or 50 hrs | Every 6 months or 100 hrs. | Every year or 150 hrs. | |
|---------------------------------|--------------|--|--------------------------|--------------------------|----------------------------|------------------------------|--|
| Engine Oil | Check level | <input type="checkbox"/> | | | | | |
| | Change | | <input type="checkbox"/> | | | | |
| Spark Plug | Check-Clean | | | | <input type="checkbox"/> | | |
| | Replace | | | | | <input type="checkbox"/> | |
| Spark Arrester (optional parts) | Clean | | | | <input type="checkbox"/> | | |
| Idle Speed | Check-adjust | | | | | <input type="checkbox"/> (1) | |
| Valve Clearance | Check-adjust | | | | | <input type="checkbox"/> (1) | |
| Fuel Tank and Strainer | Clean | | | | | <input type="checkbox"/> (1) | |
| Fuel Line | Check | Every 2 years (replace if necessary) (1) | | | | | |

(1) These items should be serviced by your servicing dealer unless you have the proper tools and are mechanically proficient. Refer to manual for service procedures.

MAINTENANCE

REFUELING

Use unleaded gasoline to produce fewer engine and spark plug deposits and extend exhaust system life.

ADDING FUEL

1. Remove the fuel tank cap (Fig. 16).
2. Add fuel to the bottom of the fuel level limit in the neck of the fuel tank. Do not overfill. Wipe up spilled fuel before starting the snowblower.

Fuel tank capacity: 84.5 fl. oz. (2.5 L).

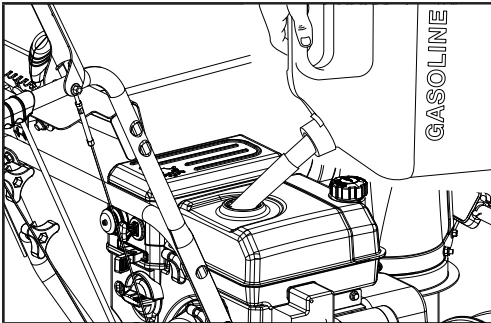

Figure 16

CHECK ENGINE OIL LEVEL

1. Check the oil with engine stopped and level.
2. Remove the oil cap/dipstick and wipe it clean (Fig. 17A).

3. Insert the oil cap/dipstick into the oil filler neck but do not screw it in, then remove it to check the oil level (Fig. 17B).
4. If the oil level is near or below the lower limit mark on the dipstick, remove the oil cap/dipstick, and fill with the recommended oil to the upper limit mark. Do not overfill (Fig. 17B).
5. Reinstall the oil cap/dipstick.

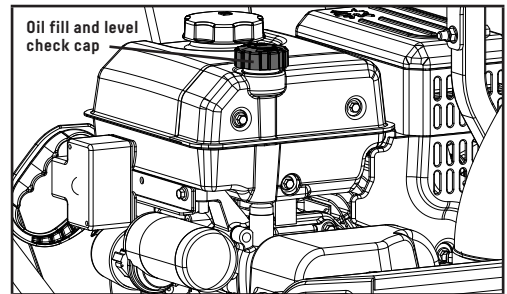

Figure 17A

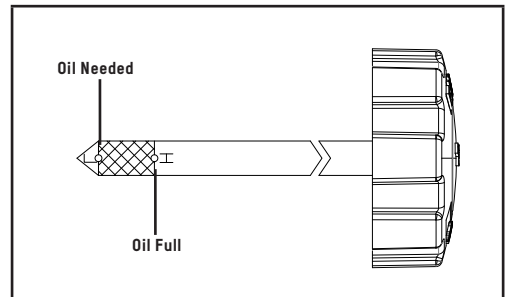

Figure 17B

**WARNING**

Gasoline is highly flammable and explosive, and you can be burned or seriously injured when refueling.

- Stop engine and keep heat, sparks, and flame away.
- Refuel only outdoors.
- Gasoline is poisonous, be careful not to touch or breathe in the vapour.

OIL CHANGE

Drain the engine oil when the engine is warm. Warm oil drains quickly and completely.

1. Turn the fuel valve lever to the OFF position to reduce the possibility of fuel spillage.
2. Place a suitable container below the snowblower to catch the used oil.
3. Remove the drain bolt and drain the oil into the container by slightly tipping the engine toward the oil cap/dipstick (Fig. 18).

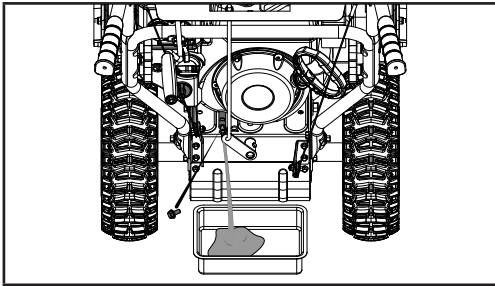

Figure 18

4. With the engine in a level position, fill to the upper limit mark on the dipstick with the recommended oil (0W-30) (Fig. 19).

5. Reinstall the oil cap/dipstick securely.

Capacity of engine oil: 16,9 fl. oz. (0.5 L)

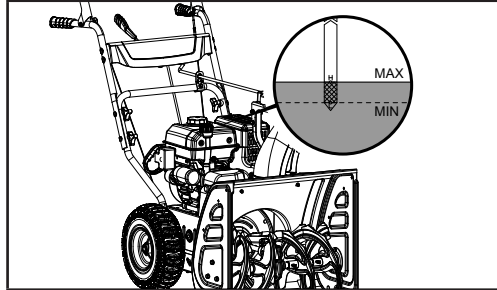

Figure 19



WARNING

- Running the engine with a low oil level can cause engine damage.
- Engine oil is poisonous, be careful not to touch it.
- With engine off but still warm, disconnect the spark plug wire and keep it away from the spark plug.
- We suggest you take used oil in a sealed container to your local recycling centre or service station for reclamation. Do not throw it in the trash, pour it on the ground, or down a drain.

REPLACING SHEAR PINS

The auger housing is shown in Fig. 20A. The augers are secured to the spiral shaft with shear pins (a) and clips (b) (Fig. 20B). If the auger should strike a foreign object or ice jam, the snowblower is designed so that the lock pins may shear.

If the augers will not turn, check to see if the lock pins have sheared (Fig. 20B). Replacement shear pins and clips are found on the back of the control panel. (Fig 20C)

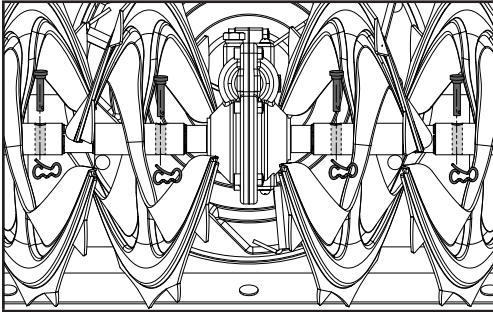

Figure 20A

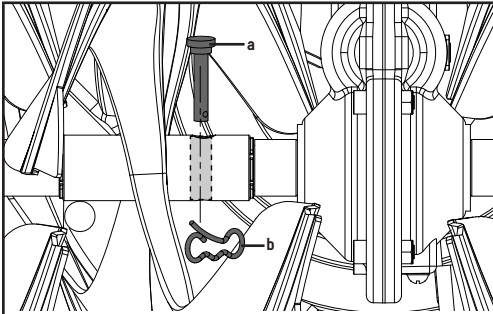

Figure 20B

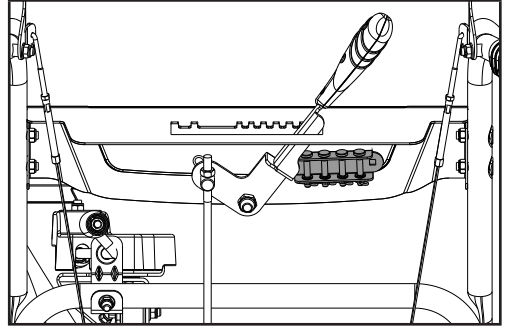

Figure 20C



WARNING

No service must be carried out before:
The engine has stopped.
The cable has been disconnected from the spark plug.

ADJUSTING SELF-DRIVE CONTROL HANDLE CABLE

Make sure that the tension on the self-drive cable is adjusted so it has between 1/4-3/8" (6.4-9.5 mm) of movement. This movement can be acquired by measuring the distance the engagement paddle moves from its starting position and the point it becomes taut and starts to move the transmission adjustment lever. If the slack is greater than 5/8" (16 mm), please adjust. Proper tension is important because you will want your snowblower to move forward properly in heavy snowfalls.

While operating the snowblower, if the self-drive control lever is too loose, tighten the nut counter-clockwise while at the same time rotating the bolt upward to reach the position of the nut (Fig. 21).

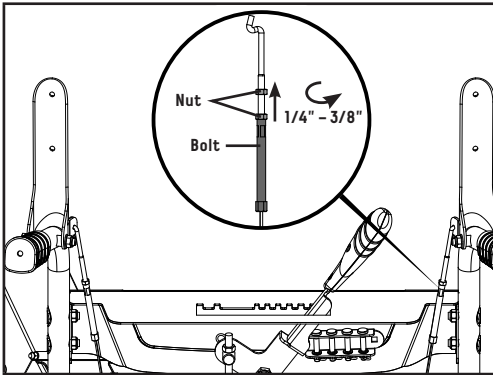

Figure 21

ADJUSTING AUGER CONTROL CABLE

Make sure that the tension on the auger control cable is adjusted so it has between 1/4-3/8" (6.4-9.5 mm) of movement. This movement can be acquired by measuring the distance the engagement paddle moves from its starting position and the point it becomes taut and starts to engage the auger. If the slack is greater than 5/8" (16 mm), please adjust. Proper tension is important because you will want your snowblower to maximize belt life in heavy snowfalls.

While operating the snowblower, if the auger control lever is too loose, tighten the nut counter-clockwise while at the same time rotating the bolt upward to reach the position of the nut (Fig. 22).

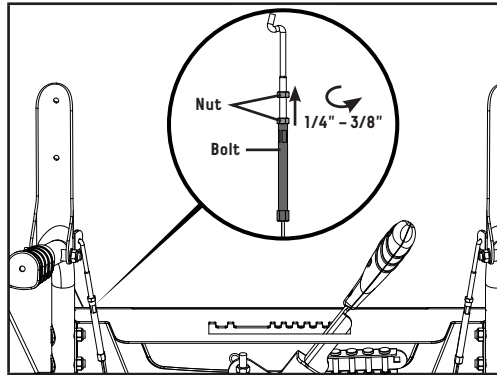

Figure 22

REPLACE AUGER DRIVE BELT WITHOUT SPLITTING THE SNOWBLOWER BODY (OPTION 1)

1. Remove the plastic belt cover (4) on the front of the engine by removing two M6 × 16 bolts (5) (Fig. 23).

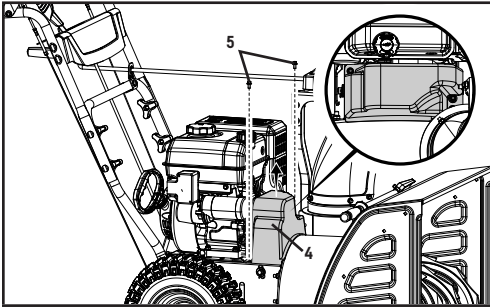

Figure 23

2. Remove clip and washer (Fig. 24A), pull support rod ½ way out from other side of snowblower (Fig. 24B).

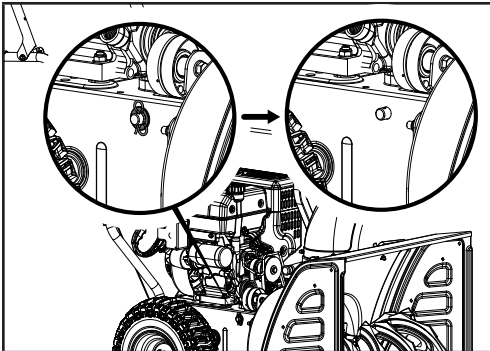

Figure 24A

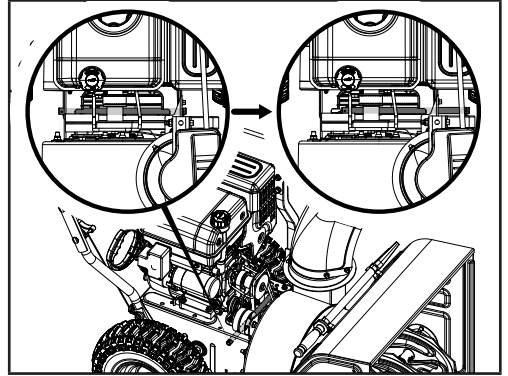

Figure 24B

3. Remove the 2 bolts (20 mm/30 mm) holding the belt guard (Fig. 25). Note the spring is loose at this point.

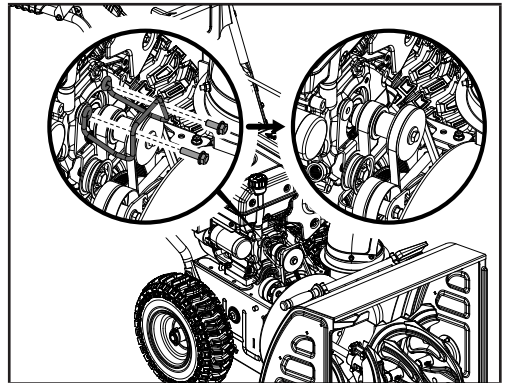

Figure 25

4. Carefully pivot the snowblower up and forward so that it rests on the auger housing. Place a piece of cardboard or moving blanket on the ground before tipping forward. Make sure all fluids are removed and spark plug is disconnected.

- Remove the base frame cover (1) from the underside of the snowblower by removing the six M6 × 16 screws which secure it (Fig 26).

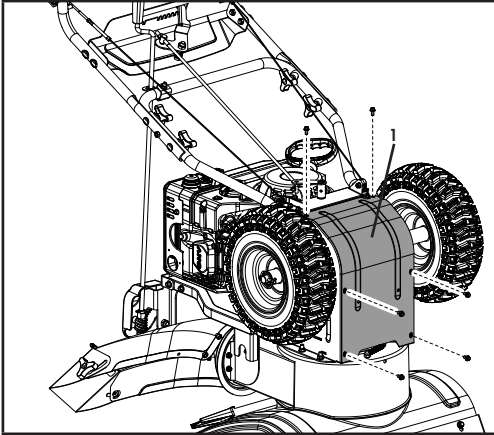

Figure 26

- Slide the speed adjusting handle to the right (Fig. 27A) and remove the loose belt by cutting it or any remaining belt pieces if the belt has already broken (Fig. 27B). If cutting the belt be careful of the tensioning pulley and arm as they are spring loaded and could cause injury when the belt is cut.

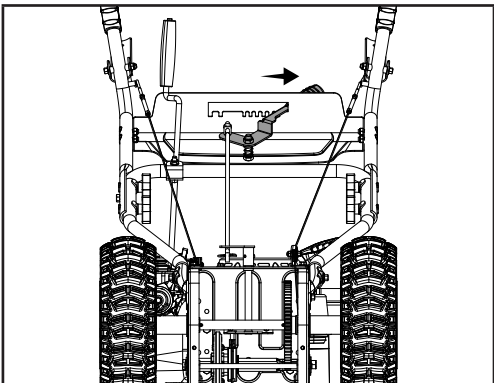

Figure 27A

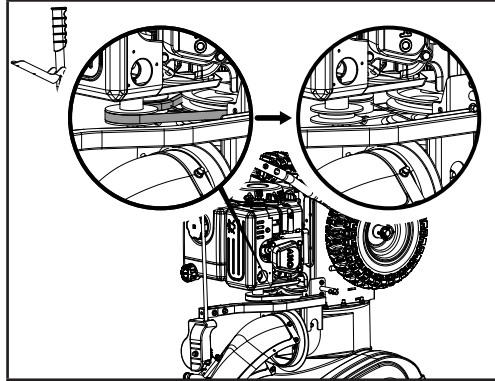

Figure 27B

- Slip the new auger drive belt into the compartment from the bottom of the snowblower placing it around the bottom of the auger drive pulley and slipping it around the front pulley on the engine. Ensure the belt is positioned between the bottom belt guard and the bottom of the auger drive pulley. You may need to remove the bolt holding the lower belt guard in place to properly seat the belt into the pulley, replace the belt guard and bolt after installing the belt into the pulley (Fig. 28A/B).

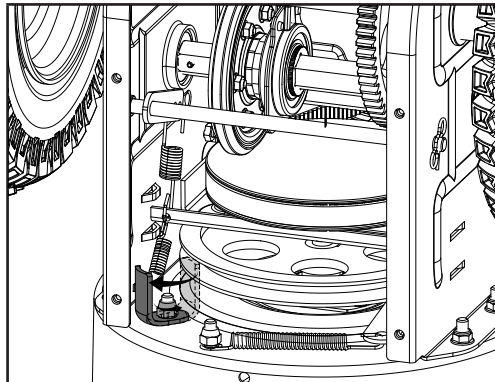

Figure 28A

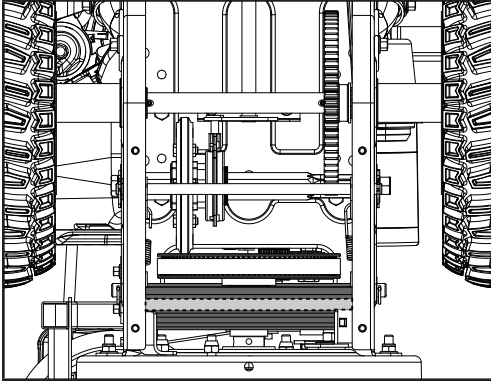

Figure 28B

8. Ensure belt is seated below the belt guide on the idler pulley pivot arm (Fig. 29).

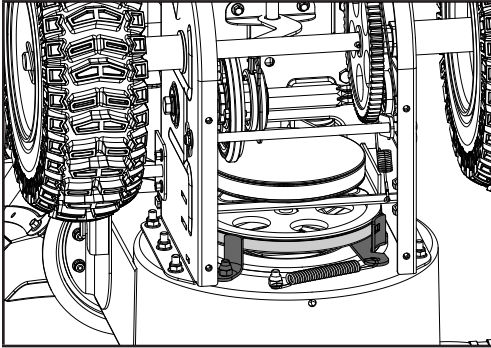

Figure 29

9. With the belt properly placed on both the front pulley and the auger drive pulley, pull the auger idler pulley back away from the belt and slip the belt inside the pulley. You can pull the recoil to rotate the pulley to help get it seated (Fig. 30).

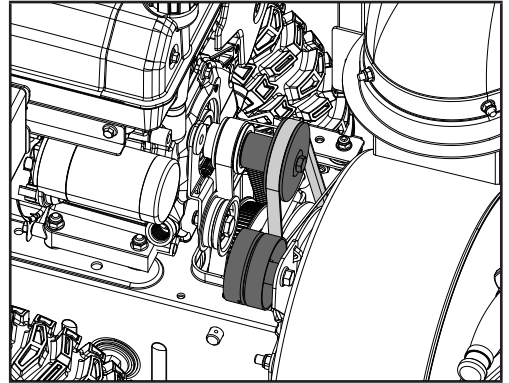

Figure 30

10. Place the belt guard back into place and install the (20 mm/30 mm) bolts that were removed earlier. Once reinstalled, make sure there is equal distance on both sides between the pulley and the guard (Fig. 31).

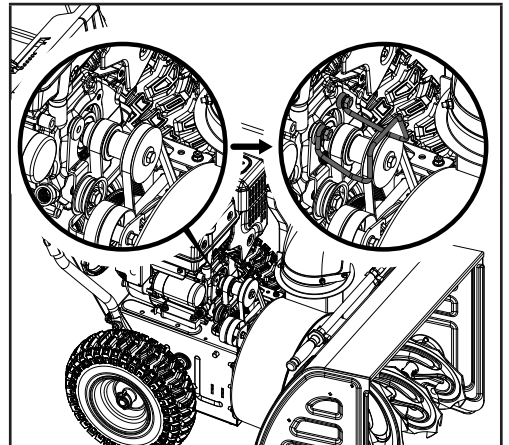

Figure 31

11. Reassemble the support rod by pushing back into place and ensure that it is properly engaged into the friction disc assembly and replace the washer and clip (Fig. 32).

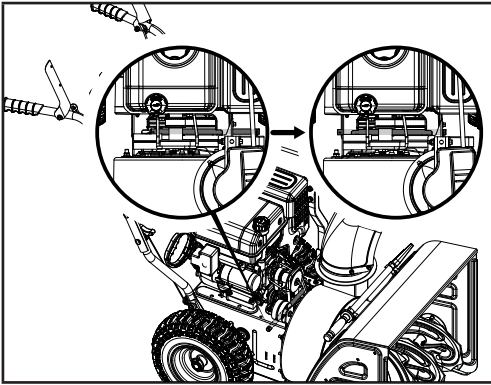

Figure 32

12. Pull the auger control handle to ensure the idler pulley is properly engaging the belt (Fig. 33). Under the belt cover area, make sure the distance on both sides between the guide and pulley is the same.

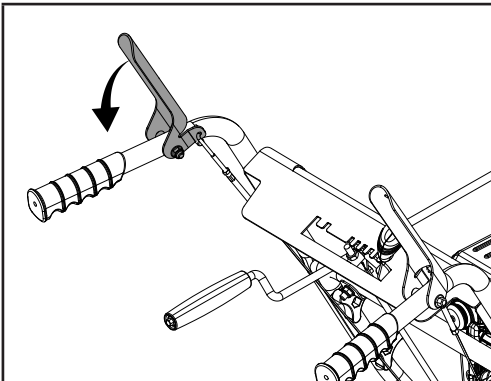

Figure 33

13. Reinstall the base frame cover.
14. Install the plastic belt cover using two M6 × 16 bolts set aside from an earlier step. Torque until snug. Do not overtighten or you risk damaging the plastic belt cover.
15. Perform a drive test to confirm everything is in working order.

REPLACE AUGER DRIVE BELT – SPLITTING THE SNOWBLOWER BODY (OPTION 2)

Tools required:

- Size 10 wrench.
- Size 12 wrench.
- Size 13 wrench (not included).

To remove and replace your snowblower's drive belt, proceed as follows:

1. Remove the plastic belt cover (4) on the front of the engine by removing two M6 × 16 bolts (5) (Fig. 34).

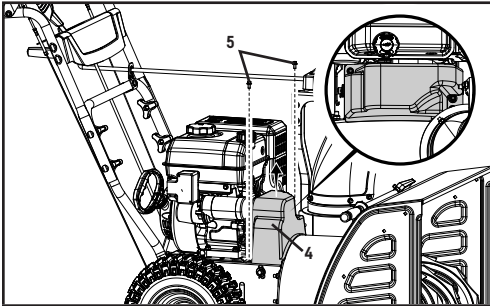

Figure 34

2. Pull out the R pin (Fig. 35).

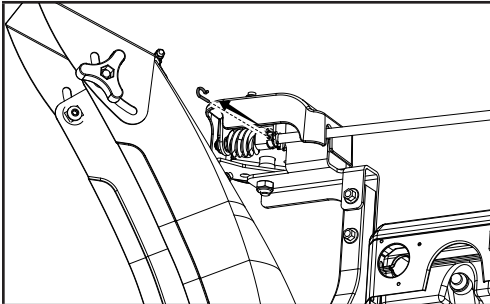

Figure 35

3. Remove the lever from the discharge chute bracket (Fig. 36).

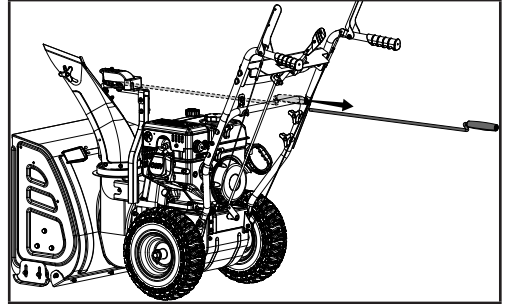

Figure 36

4. Unscrew the bolt of auger control wire (Fig. 37).

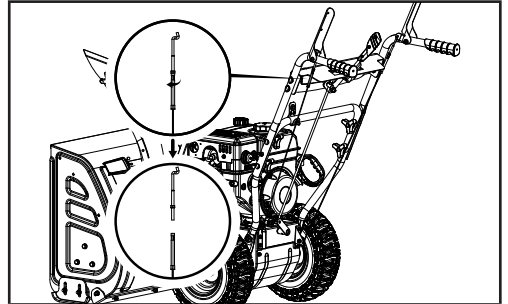

Figure 37

NOTICE:

To prevent spillage, remove all fuel from the tank by running the engine until it stops. Do not attempt to pour fuel from the engine. Disconnect the spark plug before performing any service.

- Remove the 2 bolts (20 mm/30 mm) holding the belt guard (Fig. 38). Note the spring is loose at this point.

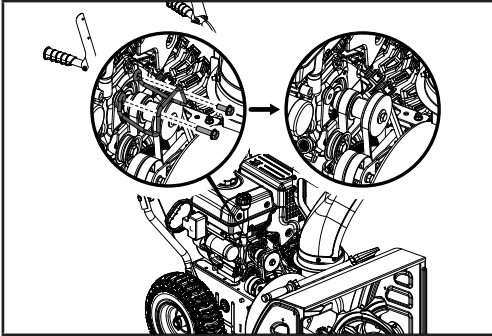

Figure 38

- Unscrew six M8 nuts to separate the auger housing from the base (Fig. 39).

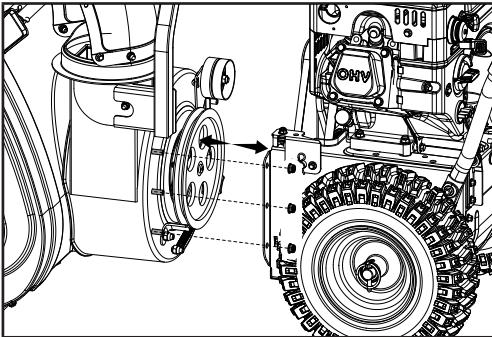

Figure 39

- Unscrew the bolt on the belt guard (Fig. 40).

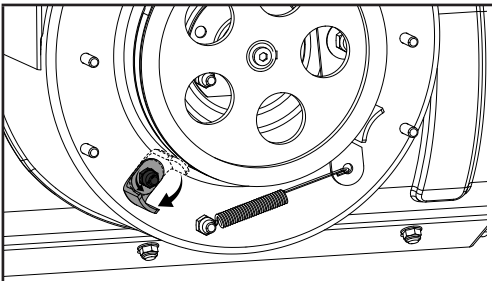

Figure 40

- Slip the drive belt off the pulley. Remove and replace the belt in reverse order ensuring that the new belt is below the spring loaded idler pulley (Fig. 41).

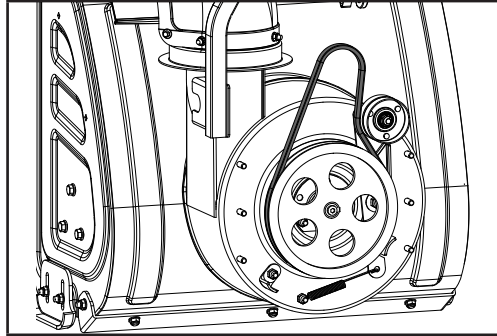

Figure 41

- Place the belt guard back into place and install the bolts (20 mm/30 mm) that were removed earlier. Once reinstalled, make sure there is equal distance on both sides between the pulley and the guard (Fig. 42).

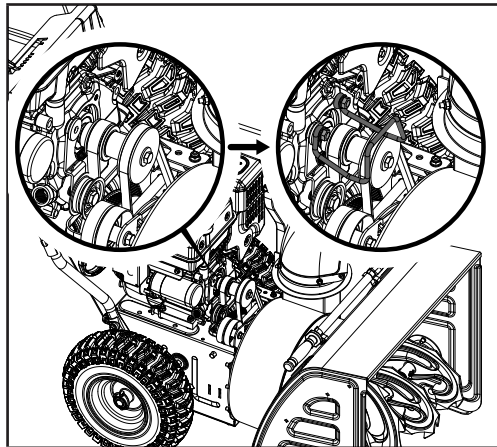

Figure 42

10. Install the plastic belt cover (4) using two M6 × 16 bolts (5) set aside from an earlier step. Torque until snug. Do not overtighten or you risk damaging the plastic belt cover (Fig. 43).

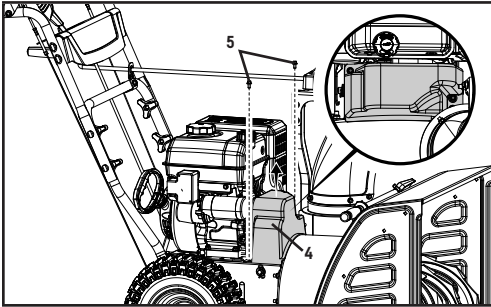

Figure 43

11. Perform a drive test to confirm everything is in working order.

REPAIR OR REPLACE FRICTION DISC

Tools required:

- 10 size wrench.
- 17 size wrench (not included).

To remove and replace your snowblower's friction disc, proceed as follows:

1. Carefully pivot the snowblower up and forward so that it rests on the auger housing. Place a piece of cardboard or moving blanket on the ground before tipping forward. Make sure all fluids are removed and spark plug is disconnected.

2. Remove the base frame cover (1) from the underside of the snowblower by removing the six M6 × 16 screws which secures it (Fig. 44A).
3. Remove the right wheel (2) by removing the axle pin on it (Fig. 44B).

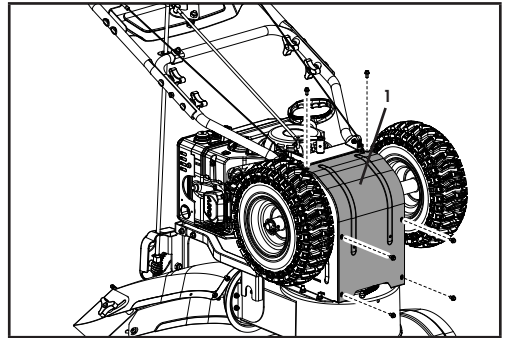

Figure 44A

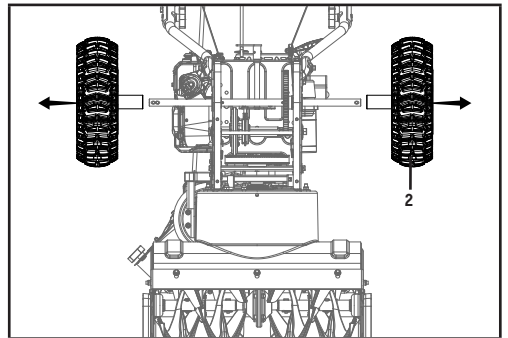

Figure 44B

NOTICE:

If the snowblower fails to drive with the drive control engaged, and performing the drive control cable adjustment fails to correct the problem, the friction disc may need to be replaced.

To prevent spillage, remove all fuel from the tank by running the engine until it stops. Do not attempt to pour fuel from the engine. Disconnect the spark plug before performing any service.

- Carefully remove the M10 hex nut (3) which secures the hex shaft (4) to the snowblower frame and lightly tap the shaft's end to dislodge the ball bearing from the right side of the frame (Fig. 45).

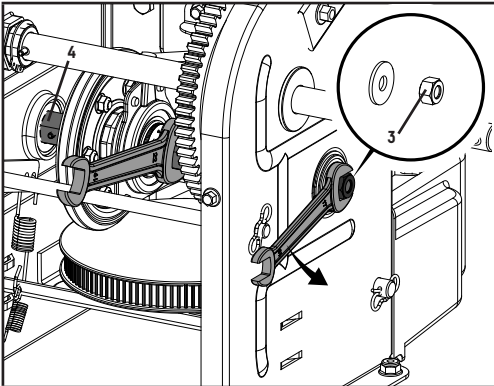

Figure 45

- Carefully position the hex shaft downward and to the left before carefully sliding the friction disc assembly (5) off the shaft (Fig. 46).

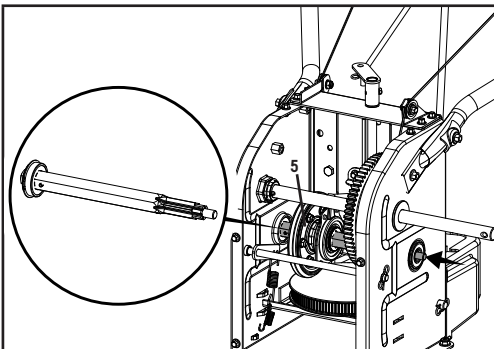

Figure 46

- Unscrew the six M6 × 16 bolts (6) of the friction disc assembly to discard the worn friction wheel rubber ring (7) and replace with a new one (Fig. 47).

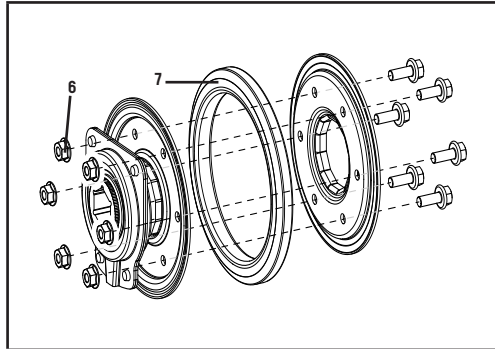

Figure 47

- Follow the previous steps in reverse order to reassemble the parts (Fig. 48).

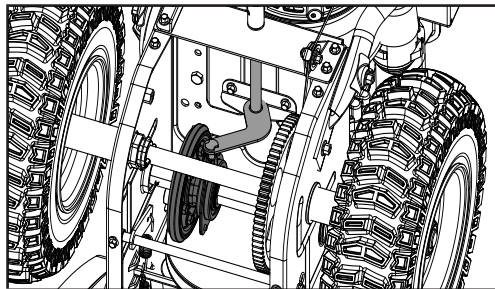

Figure 48

- Perform a drive test to confirm everything is in working order.

LUBRICATION

Lubricate the linkage every 10 hours of use and before long-term storage. Use 0W-30 oil.

No parts inside the gearbox are to be lubricated. All bearings and bushings are permanently lubricated and require no maintenance. Lubricating these parts will only result in the grease getting on to the friction wheel and disc drive plate, which could damage the rubber clad friction wheel.

LONG-TERM STORAGE

Never store the machine with gasoline in the fuel tank in a confined area with bad ventilation. Gasoline fumes could reach open flames, sparks and cigarettes etc.

To avoid the engine freezing and problems starting the engine, leave the engine running for 5-10 minutes after your work has been completed. This will ensure all moisture will disappear that would otherwise cause starting problems.

If the machine is to be stored for a longer period than 30 days, the following procedures are recommended.

1. Start the engine and let it run until it stops due to lack of fuel.
2. Change the engine oil if it has not been done for 3 months.
3. Remove the spark plug and empty a little engine oil (about 1 oz {30 mL}) in the hole. Crank the engine a couple of times. Replace the spark plug.
4. Clean the whole machine thoroughly.
5. Lubricate all the parts as stated in LUBRICATION section above.

6. Inspect the machine for damage, and repair if necessary.
7. Touch up any paint damage.
8. Apply rust protection to the metal surfaces.
9. Store the machine indoors if possible.

TRANSPORTING

If the engine has been running, allow it to cool for at least 15 minutes before loading the machine on the transport vehicle. A hot engine and exhaust system can burn you and can ignite some materials.

Keep the engine level when transporting to reduce the possibility of fuel leakage. Move the fuel valve lever to the OFF position.

SPECIFICATIONS

SNOWBLOWER SPECIFICATIONS

- Stages..... 2
- Speed Control..... 6 forward/2 reverse
- Auger Diameter..... 12" (30 cm)
- Clearing Width..... 24" (61 cm)
- Clearing Height..... 21" (53 cm)
- Wheel Diameter..... 13" (33 cm)

ENGINE SPECIFICATIONS

- Brand..... Champion Power Equipment
- Displacement..... 224 cc
- Engine Model..... R225S
- Start Type..... Electric, Recoil

OIL SPECIFICATIONS

- Oil Capacity..... 16.9 fl. oz. (0.5 L)
- Oil Type..... 0W-30

FUEL SPECIFICATIONS

- Fuel Capacity..... 84.5 fl. oz. (2.5 L)

SPECIFICATIONS

SPECIFICATIONS

PARTS LIST DIAGRAM

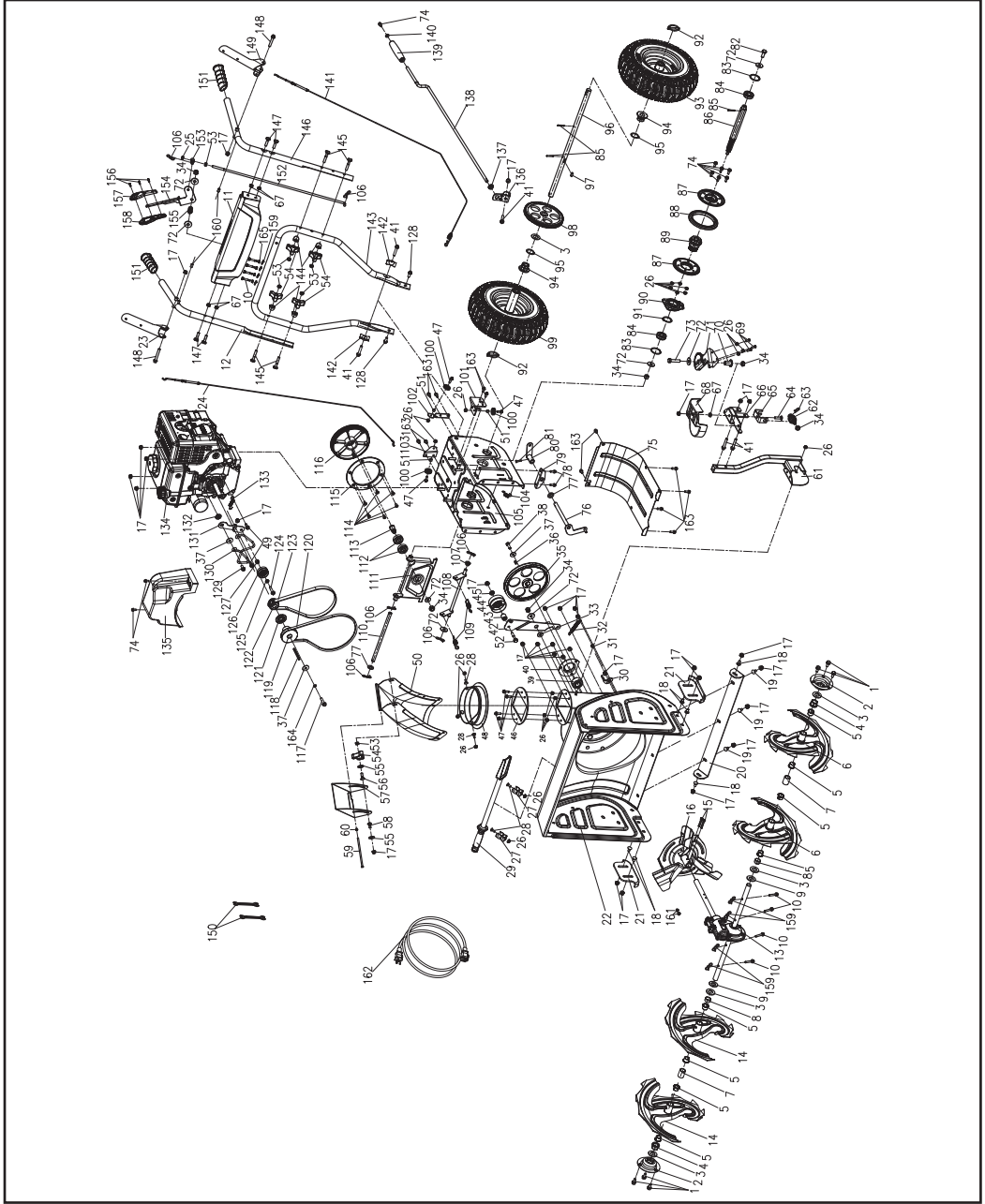

PARTS LIST

| # | Part Number | Description | Qty. |
|----|-----------------|--|------|
| 1 | 30913070165000 | Hexagon Flange Bolt, M8 x 16, Blue White Zinc | 6 |
| 2 | 23052000115000A | Bearing Support, Ⓞ2, White Zinc | 2 |
| 3 | 23092000055000A | Flat Washer, Ⓞ20 x Ⓞ37 x 2, Blue White Zinc | 5 |
| 4 | 23053000035000A | Bearing Sheath, Auger | 2 |
| 5 | 23051000130001B | T Type Bearing Sheath, Auger, Black | 8 |
| 6 | 23055000110001N | Left Auger Assembly, Black | 2 |
| 7 | 23051000120001B | Long Bearing Sheath, Auger, Ⓞ19.4 x Ⓞ24.2 x 25.3, Black | 4 |
| 8 | 23051000110001B | Short Bearing Sheath, Auger, Ⓞ19.4 x Ⓞ24.2 x 16, Black | 2 |
| 9 | 22627000125000A | Wool Felt Washer, Ⓞ40 x Ⓞ20 x 3, White | 2 |
| 10 | 23093000025000A | Shear Pin, Ⓞ6 x 35.5, Blue White Zinc | 4+4 |
| 11 | 23043000020209A | Handle Panel Assembly, Green 7733C | 1 |
| 12 | 23063000570001A | Right Upper Handle Assembly, Black | 1 |
| 13 | 23029000155000A | Worm Gear Box Assembly, 24" | 1 |
| 14 | 23055000100001N | Right Auger Assembly, Black | 2 |
| 15 | 30223010055000 | Hexagon Socket Head Cap Screw, M6 x 40, Black Zinc | 2 |
| 16 | 23055000170001A | Fan Impeller Assembly, Black | 1 |
| 17 | 30323060035000 | Flange Locking Nut, M8, All Metal Hexagon, Blue White Zinc | 33 |
| 18 | 30913090025000 | Half-Round Head Square Neck Bolt, M8 x 20, Blue White Zinc | 6 |
| 19 | 30913090015000 | Half-Round Head Square Neck Bolt, M8 x 16, Blue White Zinc | 3 |
| 20 | 23032000400001N | Snow Shovel Plate, 24", Black | 1 |
| 21 | 23032000230001N | Sled, 5,159.7 X 85, Black | 2 |

| # | Part Number | Description | Qty. |
|----|-----------------|--|------|
| 22 | 23035000220209N | Big Housing Assembly, Green 7733C | 1 |
| 23 | 23062000160001B | Right Trigger, Black | 1 |
| 24 | 23068000235000A | Self-Driving Cable Assembly, 970 mm | 1 |
| 25 | 30313090025000 | Hexagon Locking Nut, M8, White Zinc | 1 |
| 26 | 30323060015000 | Flange Locking Nut, M6, All Metal Hexagon, Blue White Zinc | 22 |
| 27 | 23092000075000A | Bracket, Snow Removal, Δ1.2, 39.2 x 30.4 x 13, White Zinc | 2 |
| 28 | 30913090035000 | Half-Round Head Square Neck Bolt, M6 x 16, Blue White Zinc | 4 |
| 29 | 23002000135000 | Snow Removal (Shovel) Assembly, Black | 1 |
| 30 | 23032000135000A | Belt Support, Ⓞ3,40 x 38 x 20.5, White Zinc | 1 |
| 31 | 2303300002A | Bushing, Ⓞ8 x Ⓞ12 x 7, White Zinc | 1 |
| 32 | 2303800001A | Tension Spring, 65Mn, Big Tension Wheel, White Zinc | 1 |
| 33 | 23034000315000B | Bushing, Ⓞ25 x Ⓞ10.2 x 5.8, Large Tension Board | 1 |
| 34 | 23093000125000A | Hexagon Locking Nut, M10, Blue White Zinc | 6 |
| 35 | 23034000135000B | Big Triangle Pulley, Ⓞ200 x 15.7, Black | 1 |
| 36 | 23093000165000A | Flat Key, 6 x 6 x 15, Black | 1 |
| 37 | 23032000335000A | Thickened Big Washer, Ⓞ8.2 x Ⓞ30 x 3.7, White Zinc | 3 |
| 38 | 30913040115000 | Hexagon Bolt, M8 x 25, Blue White Zinc | 1 |
| 39 | 30693010015000 | Spherical Bearing | 1 |
| 40 | 23052000125000B | Pressing Plate, Bearing, Ⓞ2, Ⓞ95 x 8.5, White Zinc | 1 |
| 41 | 30913070065000 | Hexagon Flange Bolt, M8 x 45, Blue White Zinc | 5 |
| 42 | 23032000255000B | Large Tension Board, Ⓞ3, Black | 1 |
| 43 | 23034000345000A | Sheath (Thick), Large Tension Wheel, Ⓞ20 x Ⓞ8 x 16.5 | 1 |

SPECIFICATIONS

model no. 060-3740-6 | contact us 1-844-428-7277

SPECIFICATIONS

| # | Part Number | Description | Qty. |
|----|-----------------|--|------|
| 44 | 23032000105000C | Large Tension Wheel Assembly, Ø66.5 x 36.2, Ø1.5 | 1 |
| 45 | 23034000325000A | Sheath (Thin), Large Tension Wheel, Ø20 x Ø8 x 5.5 | 1 |
| 46 | 23071000210001C | Steering Positioning Plate, Ø158.5 x 4, Black | 1 |
| 47 | 30913070105000 | Hexagon Flange Bolt, M6 x 20, Blue White Zinc | 7 |
| 48 | 23075000165001N | Steering Positioning Block Assembly, Ø195 x 51, Black | 1 |
| 49 | 23093000175000A | Hexagon Flange Bolt, 20mm, 5/16" (24UNF-2A), Black Zinc | 2 |
| 50 | 23075000120001N | Snow Bucket Assembly, 388 x 295.5 x 164.7, Black | 1 |
| 51 | 23033000185000A | Roller Sleeve, White Zinc | 3 |
| 52 | 30913040145000 | Hexagon Bolt, M8 x 40, Blue White Zinc | 1 |
| 53 | 30313060025000 | Hexagon Nut, M8, Blue White Zinc | 6 |
| 54 | 21061000400001A | Rotating Knob, Black | 5 |
| 55 | 23071000140001B | Snow Bucket Washer, Black | 2 |
| 56 | 30913090045000 | Half-Round Head Square Neck Bolt, M8 x 25, Blue White Zinc | 1 |
| 57 | 23075000100001N | Small Snow Bucket Assembly, Black | 1 |
| 58 | 23099000045000A | Flat Head Inner Hexagon Bolt, M8 x 17, White Zinc | 1 |
| 59 | 23093000155000A | Hinge Pin, Ø5, White Zinc | 1 |
| 60 | 30333020025000 | Cap Nut, M5, Blue White Zinc | 1 |
| 61 | 23075000130001N | Bracket Assembly, 178 x 92.5 x 392, Black | 1 |
| 62 | 23073000115000A | Steering Worm, Ø29.2 x 61, White Zinc | 1 |
| 63 | 23093000135000A | R Pin, Ø2.5 x 26.3 x 12.3, White Zinc | 1 |
| 64 | 30933010035000 | Half-Round Head Square Neck Bolt, M8 x 30, Blue White Zinc | 1 |
| 65 | 23073000135000A | Worm Bracket, 64 x 40 x 24, Black | 1 |
| 66 | 23062000415000C | Connection Plate, 140 x 98.5 x 148, T=3.5 | 1 |

| # | Part Number | Description | Qty. |
|----|-----------------|---|------|
| 67 | 30333040045000 | Serrated Anti-Slip And Anti-Loose Hexagon Flange Nut, M8, Blue White Zinc | 5 |
| 68 | 23041000330001A | Worm Protection Cover, Pp+Gf30, Black | 1 |
| 69 | 30213020045000 | Machine Teeth Screw, M6 x 16, White Zinc | 3 |
| 70 | 23024000195000A | Spacer Bushing, Worm Wheel Plate, Ø29 x Ø25.6 | 1 |
| 71 | 23072000115000B | Worm Wheel Plate, T=3.2, 102.5 x 82.9 x 86.2, Black | 1 |
| 72 | 30512050045000 | Big Washer, Ø10, Blue White Zinc | 8 |
| 73 | 30913030045000 | Half-Thread Hexagon Bolt, M10 x 45, White Zinc | 1 |
| 74 | 30913070015000 | Hexagon Flange Bolt, M6 x 16, Blue White Zinc | 9 |
| 75 | 23032000160001N | Big Bottom Plate, Black | 1 |
| 76 | 23032000195000A | Gear Shift Fork Assembly, Ø13, White Zinc | 1 |
| 77 | 23092000045000A | Flat Washer, Ø14 x Ø25 x 2.5, Blue White Zinc | 2 |
| 78 | 30913070125000 | Hexagon Flange Bolt, M6 x 10, Blue White Zinc | 2 |
| 79 | 23032000185000A | Shifting Fork Plate, T=1.5, 95 x 22 x 26.5, White Zinc | 1 |
| 80 | 23062000255000A | Gear Link Plate Assembly, Black | 1 |
| 81 | 30913040135000 | Hexagon Bolt, M5 x 20, Black Zinc | 1 |
| 82 | 30913040065000 | Hexagon Bolt, M10 x 20, Blue White Zinc | 1 |
| 83 | 23092000065000A | Shaft Ring, Ø38 x Ø43.6 x 1, Black | 2 |
| 84 | 23013000025000A | Bearing, 6203Z, 1.6 x 1 | 2 |
| 85 | 30823060015000 | Elastic Column Pin, 4 x 30, Black | 3 |
| 86 | 23033000105000A | Wheeled Six Party Shaft, Ø17 x 22 x 253, White Zinc | 1 |
| 87 | 23032000285000B | Friction Wheel Clamp, Ø117.6, White Zinc | 2 |
| 88 | 23036000105000A | Friction Wheel Rubber Ring, Ø127 x 12.4 | 1 |
| 89 | 23034000285000B | Wheeled Six Party Sleeve, Ø52 x 52.9 | 1 |

| # | Part Number | Description | Qty. |
|-----|-----------------|--|------|
| 90 | 23032000215000A | Shifting Fork Riveting, White Zinc | 1 |
| 91 | 30423010065000 | A Type External Circlips, Ø35, Black | 1 |
| 92 | 23093000145000A | O Type Elastic Pin, Ø6.2 x 40, Blue White Zinc | 2 |
| 93 | 2301900010D | Left Wheel Assembly, 13*4.1 Inch, Black | 1 |
| 94 | 23034000255000B | Hexagon Bushing, Ø19 x Ø45 x 25.3 | 2 |
| 95 | 30423010075000 | A Type External Circlips, Ø30, Black | 2 |
| 96 | 23013000115000B | Wheel Shaft, Ø19, 22", Black | 1 |
| 97 | 31013010045000 | Flat Key, 6 x 6 x 18, Black | 1 |
| 98 | 23034000105000A | Transmission Gear | 1 |
| 99 | 2301900011D | Right Wheel Assembly, 13*4.1 Inch, Black | 1 |
| 100 | 23061000130001B | Wire Roller, Black | 3 |
| 101 | 23035000125000B | Front Wire Support Seat Assembly, T=2.5, White Zinc | 1 |
| 102 | 23032000175000B | Clutch Wire Support Seat, T=2.5, White Zinc | 1 |
| 103 | 23062000145000B | Self Driving Wire Support Seat, T=2.5, White Zinc | 1 |
| 104 | 23038000125000C | Extension Spring, Ø8.5 X 44.9, White Zinc | 1 |
| 105 | 23035000110209N | Housing Assembly, Green 7733C | 1 |
| 106 | 22698000065000A | B Pin, Ø2*38*18, White Zinc | 6 |
| 107 | 23034000355000A | Rocker Arm Spacer Bushing, Ø10.1 x Ø20 x 10 | 1 |
| 108 | 23032000275000A | Rocker Arm, White Zinc | 1 |
| 109 | 23068000125000A | Self-Driving Extension Spring, Ø2.1 x Ø15 x 86.5, White Zinc | 2 |
| 110 | 23033000335000A | Bracket Shaft, Ø12.5 x 245 | 1 |
| 111 | 23035000140001B | Friction Disc Bracket Assembly, Black | 1 |
| 112 | 30613010075000 | Deep Groove Ball Bearing, 6203RS | 2 |
| 113 | 23033000115000B | Large Synchronous Pulley Shaft, Ø17 x Ø20 x 39.3, Black | 1 |

| # | Part Number | Description | Qty. |
|-----|-----------------|---|------|
| 114 | 30213010035000 | Cross Recessed Countersunk Head Screw, M6 x 12, Blue White Zinc | 6 |
| 115 | 23034000195000A | Large Synchronous Pulley Side Plate, Ø169.5 | 1 |
| 116 | 23034000185000C | Large Synchronous Pulley, Ø170 | 1 |
| 117 | 3091308004 | Hexagon Flange Bolt M8 x 30, Blue White Zinc | 1 |
| 118 | 23013000015000A | Flat Key, 4.78 x 4.78 x 70, Black | 1 |
| 119 | 23034000145000C | Small Triangle Belt Pulley, Ø19 x Ø72.5 x 49.5, Black | 1 |
| 120 | 23096000175000A | Triangle Belt, 4LXP875 | 1 |
| 121 | 23034000205000B | Small Synchronous Pulley Bushing, Ø46 x 4 | 1 |
| 122 | 23034000165000B | Small Synchronous Pulley, Ø47 x 31.9 | 1 |
| 123 | 23096000165000A | Synchronous Belt, 740 x 5 mm | 1 |
| 124 | 30913070195000 | Hexagon Flange Bolt, M8 x 35, Blue White Zinc | 1 |
| 125 | 23034000265000A | Shaft Sheath, Small Tension Pulley, Ø8 x Ø15 x 6.1 | 1 |
| 126 | 23032000115000A | Small Tension Pulley Assembly, Ø45 x 19.4 | 1 |
| 127 | 23034000275000B | Shaft Sheath, Small Tension Pulley, Ø8 x Ø15 x 11.5 | 1 |
| 128 | 30913070185000 | Hexagon Flange Bolt, M8 x 20, Blue White Zinc | 2 |
| 129 | 23093000205000A | Hexagon Flange Bolt, 30mm, 5/16" (24UNF-2A), White Zinc | 1 |
| 130 | 23033000075008A | Belt Lever, Ø6, Black | 1 |
| 131 | 23032000265000A | Small Tensioning Plate, Ø3, White Zinc | 1 |
| 132 | 23034000295000B | Small Tensioning Plate Cushion, Ø8.2 x Ø25 x 6.3 | 1 |
| 133 | 23038000135000A | Small Tension Pulley Spring, Ø1.5 x Ø10.5 x 69.3, White Zinc | 1 |
| 134 | 2030100213A | Engine, R225DS, 224CC | 1 |
| 135 | 23041000730001B | Belt Protection Cover, Black | 1 |
| 136 | 23062000495000A | Rocker Bracket, T=2.76 X 32 X 30, Black | 1 |

SPECIFICATIONS

| # | Part Number | Description | Qty. |
|-----|-----------------|---|------|
| 137 | 21066000135000A | Cable Protective Sleeve, Black | 1 |
| 138 | 23063000305000B | Rocker, Ø10 X 875, Black | 1 |
| 139 | 23061000220001B | Rocker Sheath, Ø10.5, Black | 1 |
| 140 | 23092000015000A | Adjusting Washer, Ø6.1 x Ø15 x 1.6, Black | 1 |
| 141 | 23068000225000A | Throwing Snow Cable Assembly, 1164 mm | 1 |
| 142 | 23032000205000A | Dish Washer, T=2.5, White Zinc | 2 |
| 143 | 23062000270001N | Lower Handle, Black | 1 |
| 144 | 21061000113201A | Curved Washer, PA6+GF30, Black | 4 |
| 145 | 23099000035000A | Flat Head Bolt, M8 x 52, White Zinc | 4 |
| 146 | 23063000580001A | Left Upper Handle Assembly, Black | 1 |
| 147 | 23099000025000A | Flat Head Bolt, M8 x 35, White Zinc | 4 |
| 148 | 23093000185000A | Special Bolt, M8 x 55, White Zinc | 2 |
| 149 | 23062000150001B | Left Trigger, Black | 1 |
| 150 | 20121000315000A | Open End Wrenches, 10-12 mm, White Zinc | 2 |
| 151 | 23061000140001C | Handle Sheath, PVC, Black | 2 |
| 152 | 23063000195000B | Gear Connecting Rod, 547 x M8, Black | 1 |
| 153 | 23063000215000A | Column, Gear Connecting Rod, White Zinc | 1 |
| 154 | 23065000195000A | Speed Adjustment Handle, 229 x 90 x 29, Black | 1 |
| 155 | 23068000135000B | Gear Pressing Spring, Ø14.5 x 33.75, White Zinc | 1 |
| 156 | 30113010115000 | Self-Tapping Screw, ST3 x 12, Black Zinc | 3 |
| 157 | 23061000150001B | Gear Handle, Left, Black | 1 |
| 158 | 23061000160001B | Gear Handle, Right, Black | 1 |
| 159 | 23093000195000A | B pin, White Zinc, Ø2 x 28 x 11.1 | 4+4 |
| 160 | 23096000015000A | Rubber Sheath | 2 |
| 161 | 30313030015000 | Hexagon Locking Nut, M6, Black Zinc | 2 |
| 162 | 23089000035000A | Electric Start Cord, 1830mm | 1 |

| # | Part Number | Description | Qty. |
|-----|-----------------|---|------|
| 163 | 23033000485000A | Flange Triangle Self-Tapping Screw, M6 x 16, White Zinc | 12 |
| 164 | A26800800202 | Spring Washer, Ø8, Black Zinc | 1 |
| 165 | 23096000055000A | Rubber Sheath, Ø10.7 x Ø6 x 5.1, Black | 4 |

Page intentionally left blank

SPECIFICATIONS

ENGINE PARTS LIST DIAGRAM

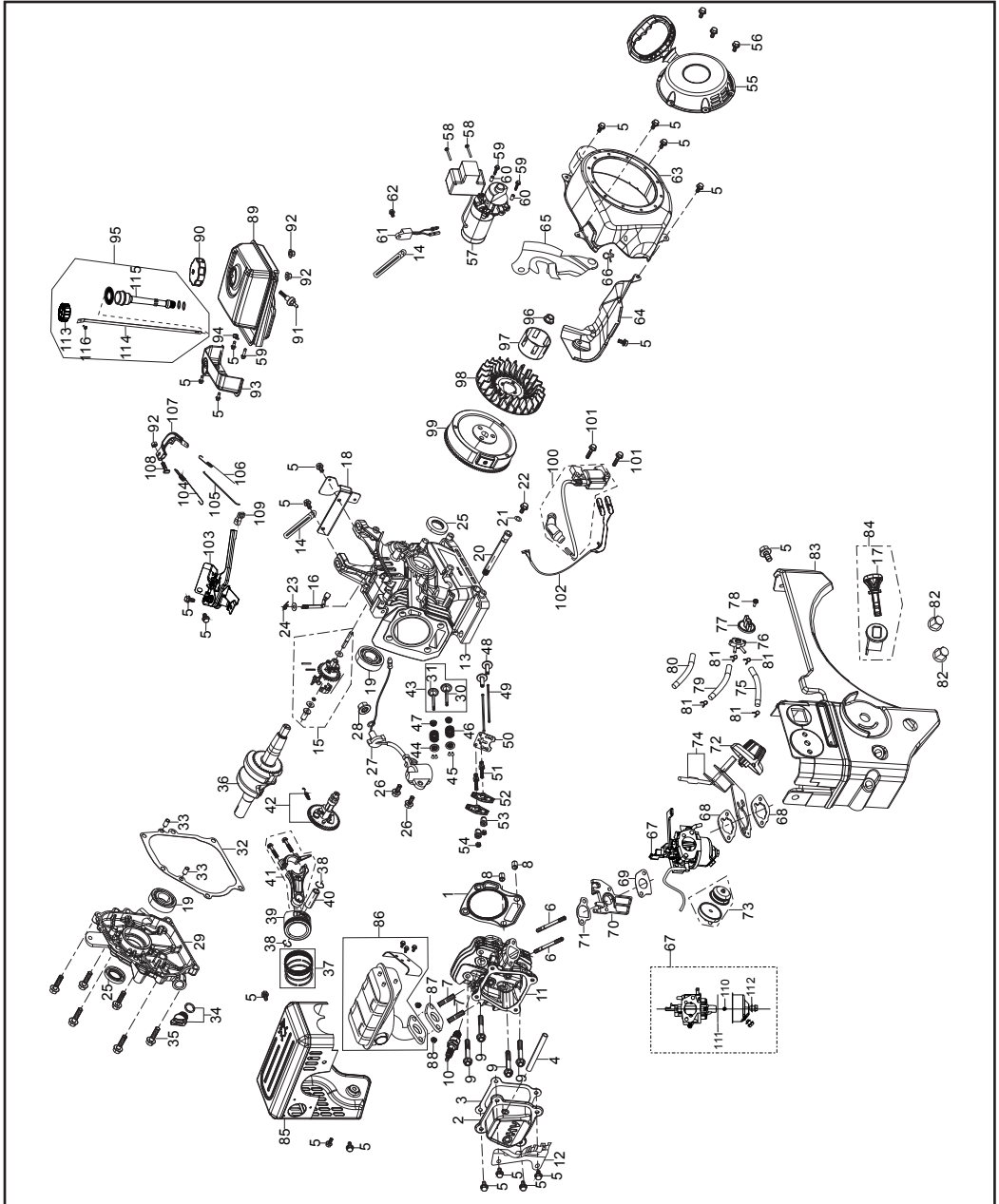

PARTS LIST

| # | Part Number | Description | Qty. |
|----|--------------------|---|------|
| 1 | 12131-Z530320-0000 | Cylinder Head Gasket | 1 |
| 2 | 12410-Z300120-0000 | Cylinder Head Cover Subassembly, Blue White Zinc | 1 |
| 3 | 12004-Z010110-0001 | Cylinder Head Cover Gasket | 1 |
| 4 | 17004-Z330110-0001 | Breather Tube | 1 |
| 5 | 90001-0612-01 | Hexagon Flange Bolt, M6 x 12, Blue White Zinc | 20 |
| 6 | 90207-Z330120-0000 | Stud, M6 x 105, Blue White Zinc | 2 |
| 7 | 90203-Z010110-0000 | Stud, M8 x 34, Black Zinc | 2 |
| 8 | 90502-1114-00 | Pin, 11 x 14 | 2 |
| 9 | 12003-Z010110-0000 | Cylinder Head Bolt, M8 x 60, Blue White Zinc | 4 |
| 10 | 30010-Z010110-0000 | Spark Plug, F6RTC | 1 |
| 11 | 12140-Z1S0110-0B00 | Cylinder Head Subassembly | 1 |
| 12 | 80057-Z330130-0000 | Front Fender | 1 |
| 13 | 11310-Z1S0110-0B00 | Crankcase Subassembly | 1 |
| 14 | 90684-Z030120-0000 | Clip | 2 |
| 15 | 16400-Z810210-0000 | Governor Gear Assembly | 1 |
| 16 | 16061-Z010110-0000 | Governor Arm | 1 |
| 17 | 35552-Z330110-0000 | Start Switch, Key | 1 |
| 18 | 30360-Z330110-H300 | Support Control Box Subassembly | 1 |
| 19 | 90547-0205-00 | Bearing, 6205 P53 | 2 |
| 20 | 11011-Z1S0110-0000 | Oil Drain Tube, 120 x 16, Blue White Zinc | 1 |
| 21 | 90408-Z010110-0000 | Washer, Ø10 x Ø15.8 x 1.5 | 1 |
| 22 | 11007-Z010110-0000 | Drain Plug Bolt, M10 x 1.25 x 15, Blue White Zinc | 1 |
| 23 | 90408-Z010210-0000 | Washer, Ø6.2 x Ø15 x 0.6 | 1 |
| 24 | 90501-Z010110-0000 | Pin, Blue White Zinc | 1 |
| 25 | 90682-Z050110-0001 | Oil Seal, Ø25 x Ø41.25 x 6 | 2 |
| 26 | 90001-0614-01 | Hexagon Flange Bolt, M6 x 14, Blue White Zinc | 2 |
| 27 | 37060-Z010120-0000 | Engine oil Sensor, W/O Nut | 1 |
| 28 | 90305-Z010210-01 | Hexagon Flange Nut, M10, Blue White Zinc | 1 |
| 29 | 11411-Z330210-0B00 | Crankcase Cover | 1 |
| 30 | 12111-Z810110-0000 | Inlet Valve | 1 |
| 31 | 12121-Z810120-0000 | Exhaust Valve | 1 |

| # | Part Number | Description | Qty. |
|----|--------------------|---|------|
| 32 | 11001-Z330120-0000 | Crankcase Gasket | 1 |
| 33 | 90502-0812-00 | Pin, 8 x 12 | 2 |
| 34 | 15030-Z010130-0B01 | Engine Oil Plug Subassembly | 1 |
| 35 | 90001-0832-01 | Hexagon Flange Bolt, M8 x 32, Blue White Zinc | 6 |
| 36 | 13300-Z1S0110-0000 | Crankshaft Assembly | 1 |
| 37 | 13200-Z140210-0099 | Piston Rings Set | 1 |
| 38 | 13122-Z510210-0000 | Piston Pin Clip | 2 |
| 39 | 13111-Z810120-0000 | Piston | 1 |
| 40 | 13121-Z810110-0000 | Piston Pin, Ø13 x Ø45.9 | 1 |
| 41 | 13010-Z810210-0000 | Connecting Rod | 1 |
| 42 | 14200-Z1S0110-0009 | Camshaft Assembly | 1 |
| 43 | 12110-Z810120-0099 | Valves Set | 1 |
| 44 | 12112-Z810210-0000 | Valve Spring Retainer | 2 |
| 45 | 12109-Z810110-0000 | Valve Lock Clamp | 4 |
| 46 | 12103-Z010110-0000 | Valve Spring | 2 |
| 47 | 12101-Z810210-0000 | Seal Guide | 2 |
| 48 | 14081-Z040110-0000 | Valve Lifter | 2 |
| 49 | 14071-Z440110-0000 | Valve Rod | 2 |
| 50 | 14090-Z010110-0000 | Lifter Stopper Plate Subassembly, Blue White Zinc | 1 |
| 51 | 14313-Z010110-0000 | Valve Adjusting Bolt | 2 |
| 52 | 14311-Z010110-0000 | Valve Rocker | 2 |
| 53 | 14314-Z010110-0000 | Valve Adjusting Nut | 2 |
| 54 | 14312-Z010110-0000 | Valve Lock Nut | 2 |
| 55 | 28200-Z1S0110 | Recoil Starter Assembly | 1 |
| 56 | 90001-0608-03 | Hexagon Flange Bolt, M6 x 8, Blue White Zinc | 3 |
| 57 | 30300-Z050110-0002 | Starting Motor Assembly | 1 |
| 58 | 90103-0455-53 | Screw, M4 x 55, Black Zinc | 2 |
| 59 | 90001-0630-01 | Hexagon Flange Bolt, M6 x 30, Blue White Zinc | 3 |
| 60 | 90502-0810-00 | Pin, 8 x 10 | 2 |
| 61 | 37050-Z010210-0000 | Oil Protector, Zinc Plated | 1 |
| 62 | 90001-0512-01 | Hexagon Flange Bolt, M5 x 12, Blue White Zinc | 1 |
| 63 | 28110-Z050110 | Shroud | 1 |
| 64 | 19304-Z1S0110-0000 | Cylinder Body Shroud, Blue White Zinc | 1 |
| 65 | 19340-Z050120-0000 | Lower Shield, Blue White Zinc | 1 |

model no. 060-3740-6 | contact us 1-844-428-7277

SPECIFICATIONS

| # | Part Number | Description | Qty. |
|----|--------------------|--|------|
| 66 | 90684-Z250110-0000 | Clip | 1 |
| 67 | 16100-Z1S0110-0009 | Carburetor Assembly | 1 |
| 68 | 17001-Z330110-0000 | Air Cleaner Gasket | 2 |
| 69 | 16001-Z010110-0000 | Carburetor Gasket | 1 |
| 70 | 16003-Z010110-0001 | Carburetor Insulator Plate | 1 |
| 71 | 16002-Z050110-0000 | Carburetor Insulator Gasket | 1 |
| 72 | 16235-Z330130-VG01 | Carburetor Choke Handle Rubber Sleeve | 1 |
| 73 | 16210-Z330110-0001 | Primer Bulb | 1 |
| 74 | 16900-Z330120-0000 | Choke Control Assembly | 1 |
| 75 | 90686-Z080510-0001 | Fuel Pipe, Ø4.5 x Ø8.5 x 220 | 1 |
| 76 | 16752-Z1S0110-0000 | Fuel On-Off Switch | 1 |
| 77 | 35643-Z1S0110-VG01 | Knob | 1 |
| 78 | 90103-0314-51 | Screw, M3 x 14, Blue White Zinc | 1 |
| 79 | 90686-Z1S0210-0001 | Fuel Pipe, Ø4.5 x Ø8.5 x 50 | 1 |
| 80 | 30431-Z010110-0001 | Rubber Jacket, Ø9.5 x Ø11 x 90 | 1 |
| 81 | 90740-Z010210-0000 | Clamp, Ø7.5, Blue White Zinc | 4 |
| 82 | 90314-Z130210-0000 | NUT, M6 x 17, Chrome Plated | 2 |
| 83 | 17100-Z330110-0101 | Air Cleaner | 1 |
| 84 | 35540-Z330110-0000 | Stop Engine Switch Subassembly | 1 |
| 85 | 18140-Z1S0110-H301 | Scald Resistant Cover | 1 |
| 86 | 18160-Z330120-0002 | Muffler Body | 1 |
| 87 | 18001-Z010110-0000 | Exhaust Outlet Gasket | 1 |
| 88 | 90303-0800-31 | Hexagon Flange Nut, M8, Blue White Zinc | 2 |
| 89 | 16620-Z330310-H601 | Fuel Tank | 1 |
| 90 | 16730-Z330120-Q201 | Fuel Tank Cover | 1 |
| 91 | 16680-Z010110-0001 | Fuel Tank Oil Outlet Subassembly | 1 |
| 92 | 90305-0600-31 | Hexagon Flange Nut, M6, Blue White Zinc | 3 |
| 93 | 16667-Z330110-0001 | Fuel Tank Decorated Plate | 1 |
| 94 | 15005-Z330210-0000 | Oil Fueling Tube Hoop | 1 |
| 95 | 15010-Z330130-0B01 | Oil Dipstick Subassembly | 1 |
| 96 | 13501-Z010110-0000 | Flywheel Nut, M14 x 1.5, Blue White Zinc | 1 |
| 97 | 28002-Z300110-0000 | Starter Pulley, Blue White Zinc | 1 |
| 98 | 19352-Z010110-0000 | Impeller | 1 |

| # | Part Number | Description | Qty. |
|-----|---------------------|---|------|
| 99 | 13510-Z1S0110-0000 | Flywheel Subassembly | 1 |
| 100 | 30400-Z330110-0001 | Ignition Coil | 1 |
| 101 | 90001-0625-01 | Hexagon Flange Bolt, M6 x 25, Blue White Zinc | 2 |
| 102 | 30423-Z050310-0000 | Ignition Coil Stop Engine Wire | 1 |
| 103 | 16520-Z330120-0000 | Throttle Control Assembly | 1 |
| 104 | 16063-Z050410-0000 | Spring, Governor, Blue White Zinc | 1 |
| 105 | 16062-Z010110-0000 | Governor Rod, Blue White Zinc | 1 |
| 106 | 16012-Z010110-0000 | Throttle Valve Returning Spring | 1 |
| 107 | 16070-Z010110-0000 | Governor Support Subassembly, Blue White Zinc | 1 |
| 108 | 16072-Z010110-0000 | Governor Support Bolt, M6 x 21, Blue White Zinc | 1 |
| 109 | 16015-Z050110-VG01 | Throttle Handle Rubber Sleeve | 1 |
| 110 | 16161-Z1S0110-0000 | Main Jet | 1 |
| | 16161-Z1S0210-0000 | Main Jet, Altitude 3000-6000 feet | / |
| | 16161-Z1S0310-0000 | Main Jet, Altitude 6000-8000 feet | / |
| 111 | 16112-Z050110-0000 | Seal Ring Float | 1 |
| 112 | 90681-Z050310-0000 | Seal Ring | 1 |
| 113 | 15004--Z330110-0000 | Oil Dipstick Cap | 1 |
| 114 | 15011-Z330110-0000 | Oil Dipstick | 1 |
| 115 | 15020-Z330130-0000 | Oil Filling tube, PA6 | 1 |
| 116 | 90107-4812-51 | Self-Tapping Screw, ST4.8 x 12, Blue White Zinc | 1 |

Page intentionally left blank

SPECIFICATIONS

TROUBLESHOOTING

| Problem | Possible Cause | Remedy |
|---|--|---|
| Engine fails to start. | Engine flooded. | Repeat start attempts with throttle choke OFF. |
| | Water in fuel. | Drain tank and refill with fresh fuel. |
| | Other. | Check carefully the start procedure according to this manual. |
| Engine starts hard or runs poorly. | Spark plug issues. | Replace the spark plug. |
| | Fuel cap ventilation is blocked. | Clear the ventilation. |
| Auger does not rotate. | Foreign material caught in system. | Clean. |
| | Auger drive belt slipping. | Adjust the belt and wire. |
| | Auger drive belt broken. | Replace the belt. |
| | Auger control cable is out of adjustment. | See ADJUSTING AUGER CONTROL CABLE section. |
| Auger does not stop when the lever is released. | Auger drive belt is out of adjustment. | Adjust the belt. |
| | Auger drive guide is out of adjustment. | Adjust the guide. |
| | Auger control cable is out of adjustment. | See ADJUSTING AUGER CONTROL CABLE section. |
| Snowblower veers to one side. | Tire pressure not equal. | Adjust the tire pressure. |
| | Wheel spring lock pin is inserted on one side. | Check the wheel locks. |
| | Shoes are mounted unevenly. | Adjust shoes. |
| | Scraper blade uneven. | Adjust scraper blade and shoes. |
| Snowblower does not drive. | Drive cable out of adjustment. | Adjust drive cable. See ADJUSTING SELF-DRIVE CONTROL HANDLE CABLE section. |
| | Auger drive belt worn/broken. | Replace traction drive belt. See REPLACE AUGER DRIVE BELT section. |
| | Friction disc worn out. | Repair or replace friction disc. See REPAIR OR REPLACE FRICTION DISC section. |

**WARNING**

Before performing any maintenance or cleaning work, always stop engine, disconnect spark plug cable and wait until the auger has come to a standstill.

**CAUTION**

Faults which can not be rectified with the aid of this table may be rectified by a specialty company only (customer service centre).

2-YEAR LIMITED WARRANTY

This CERTIFIED™ product is guaranteed for a period of 2 years from the date of original retail purchase against defects in workmanship and materials.

Subject to the conditions and limitations described below, this product, if returned to us with proof of purchase within the stated warranty period and if covered under this warranty, will be repaired or replaced (with the same model, or one of equal value or specification), at our option. We will bear the cost of any repair or replacement and any costs of labour relating thereto.

These warranties are subject to the following conditions and limitations:

- a. a bill of sale verifying the purchase and purchase date must be provided;
- b. this warranty will not apply to any product or part thereof which is worn or broken or which has become inoperative due to abuse, misuse, accidental damage, neglect or lack of proper installation, operation or maintenance (as outlined in the applicable owner's manual or operating instructions) or which is being used for industrial, professional, commercial or rental purposes;
- c. this warranty will not apply to normal wear and tear or to expendable parts or accessories that may be supplied with the product that are expected to become inoperative or unusable after a reasonable period of use;
- d. this warranty will not apply to routine maintenance and consumable items such as, but not limited to, fuel, lubricants, blades, belts, bits, fluids, tune-ups or adjustments;
- e. this warranty will not apply where damage is caused by repairs made or attempted by others (i.e. persons not authorized by the manufacturer);
- f. this warranty will not apply to any product that was sold to the original purchaser as a reconditioned or refurbished product (unless otherwise specified in writing);
- g. this warranty will not apply to any product or part thereof if any part from another manufacturer is installed therein or any repairs or alterations have been made or attempted by unauthorized persons;
- h. this warranty will not apply to normal deterioration of the exterior finish, such as, but not limited to, scratches, dents, paint chips, or to any corrosion or discolouring by heat, abrasive and chemical cleaners; and
- i. this warranty will not apply to component parts sold by and identified as the product of another company, which shall be covered under the product manufacturer's warranty, if any.

ADDITIONAL LIMITATIONS

This warranty applies only to the original purchaser and may not be transferred. Neither the retailer nor the manufacturer shall be liable for any other expense, loss or damage, including, without limitation, any indirect, incidental, consequential or exemplary damages arising in connection with the sale, use or inability to use this product.

NOTICE TO CONSUMER

This warranty gives you specific legal rights, and you may have other rights, which may vary from province to province. The provisions contained in this warranty are not intended to limit, modify, take away from, disclaim or exclude any statutory warranties set forth in any applicable provincial or federal legislation.

Made in China

Imported by

Trileaf Distribution Toronto, Canada M4S 2B8

**Champion Power Equipment, Inc. (CPE),
United States Environment Protection Agency (U.S. EPA)
Emission Control System Warranty**

Your Champion Power Equipment (CPE) engine complies with U.S. EPA emission regulations.

YOUR WARRANTY RIGHTS AND OBLIGATIONS:

The US EPA AND CPE are pleased to explain the Federal Emission Control Systems Warranty on your 2018 small off-road engine (SORE) and engine powered equipment. New engines and equipment must be designed, built and equipped, at the time of sale, to meet U.S. EPA regulations for small off-road engines (SORE). CPE warrants the emission control system on your small off-road engine (SORE) and equipment for the period of time listed below, provided there has been no abuse, neglect, unapproved modification, or improper maintenance of your equipment.

Your emission control system may include parts such as the carburetor, fuel-injection system, the ignition system, catalytic converter and fuel lines. Also included may be hoses, belts, connectors and other emission related assemblies. Where a warrantable condition exists, CPE will repair your small off-road engine (SORE) at no cost to you including diagnosis, parts and labor.

MANUFACTURER'S EMISSION CONTROL SYSTEM WARRANTY COVERAGE:

This emission control system is warranted for two years, subject to provisions set forth below. If, during the warranty period, an emission related part on your engine is defective in materials or workmanship, the part will be repaired or replaced by CPE.

OWNER WARRANTY RESPONSIBILITIES:

As the small off-road engine (SORE) owner, you are responsible for the performance of the required maintenance listed in your Owner's Manual. CPE recommends that you retain all your receipts covering maintenance on your small off-road engine, but CPE cannot deny warranty solely for the lack of receipts or for your failure to ensure the performance of all scheduled maintenance.

As the small off-road engine (SORE) owner, you should however be aware that CPE may deny you warranty coverage if your small, off-road engine (SORE) or a part has failed due to abuse, neglect, improper maintenance or unapproved modifications.

You are responsible for presenting your small off-road engine (SORE) to an Authorized CPE service outlet or alternate service outlet as described in (3)(f.) below, CPE dealer or CPE, Santa Fe Springs, Ca. as soon as a problem exists. The warranty repairs should be completed in a reasonable amount of time, not to exceed 30 days.

If you have any questions regarding your warranty rights and responsibilities, you should contact:

Champion Power Equipment, Inc.
Customer Service
12039 Smith Ave.
Santa Fe Springs, CA 90670
1-877-338-0999
tech@championpowerequipment.com

EMISSION CONTROL SYSTEM WARRANTY

The following are specific provisions relative to your Emission Control System (ECS) Warranty Coverage.

1. APPLICABILITY: This warranty shall apply to 1997 and later model year small off-road engines (SORE). The ECS Warranty Period shall begin on the date the new engine or equipment is delivered to its original, end-use purchaser, and shall continue for 24 consecutive months thereafter.

2. GENERAL EMISSIONS WARRANTY COVERAGE

CPE warrants to the original, end-use purchaser of the new engine or equipment and to each subsequent purchaser that each of its small off-road engines (SORE) is:

- a. Designed, built and equipped so as to conform to U.S. EPA emissions standards for spark-ignited engines at or below 19 kilowatts.
- b. Free from defects in materials and workmanship that cause the failure of a warranted part to be identical in all material respects to the part as described in the engine manufacturer's application for certification for a period of two years.

3. THE WARRANTY ON EMISSION-RELATED PARTS WILL BE INTERPRETED AS FOLLOWS:

a. Any warranted part that is not scheduled for replacement as required maintenance in the Owners Manual shall be warranted for the ECS Warranty Period. If any such part fails during the ECS Warranty Period, it shall be repaired or replaced by CPE according to Subsection "d" below. Any such part repaired or replaced under the ECS Warranty shall be warranted for any remainder of the ECS Warranty Period.

b. Any warranted, emissions-related part which is scheduled only for regular inspection as specified in the Owners Manual shall be warranted for the ECS Warranty Period. A statement in such written instructions to the effect of "repair or replace as necessary", shall not reduce the ECS Warranty Period. Any such part repaired or replaced under the ECS Warranty shall be warranted for the remainder of the ECS Warranty Period.

c. Any warranted, emissions-related part which is scheduled for replacement as required maintenance in the Owner's Manual shall be warranted for the period of time prior to the first scheduled replacement point for that part. If the part fails prior to the first scheduled replacement, the part shall be repaired or replaced by CPE according to Subsection "d" below. Any such emissions-related part repaired or replaced under the ECS Warranty, shall be warranted for the remainder of the ECS Warranty Period prior to the first scheduled replacement point for such emissions-related part.

d. Repair or replacement of any warranted, emissions-related part under this ECS Warranty shall be performed at no charge to the owner at a CPE Authorized Service Outlet.

e. The owner shall not be charged for diagnostic labor which leads to the determination that a part covered by the ECS Warranty is in fact defective, provided that such diagnostic work is performed at a CPE Authorized Service Outlet.

f. CPE shall pay for covered emissions warranty repairs at non-authorized service outlets under the following circumstances:

i. The service is required in a population center with a population over 100,000 according to U.S. Census 2000 without a CPE Authorized Service Outlet AND

ii. The service is required more than 100 miles from a CPE Authorized Service Outlet. The 100 mile limitation does not apply in the following states: Alaska, Arizona, Colorado, Hawaii, Idaho, Montana, Nebraska, Nevada, New Mexico, Oregon, Texas, Utah and Wyoming.

g. CPE shall be liable for damages to other original engine components or approved modifications proximately caused by a failure under warranty of an emission-related part covered by the ECS Warranty.

h. Throughout the ECS Warranty Period, CPE shall maintain a supply of warranted emission-related parts sufficient to meet the expected demand for such emission-related parts.

i. Any CPE Authorized and approved emission-related replacement part may be used in the performance of any ECS Warranty maintenance or repair and will be provided without charge to the owner. Such use shall not reduce CPE's warranty obligation.

j. Unapproved add-on or modified parts may not be used to modify or repair a CPE engine. Such use voids this ECS Warranty and shall be sufficient grounds for disallowing an ECS Warranty claim. CPE shall not be liable hereunder for failures of any warranted parts of a CPE engine caused by the use of such an unapproved add-on or modified part.

EMISSION-RELATED PARTS INCLUDE THE FOLLOWING: (using those portions of the list applicable to the engine)

| Systems covered by this warranty | Parts Description |
|----------------------------------|---|
| Fuel Metering System | Fuel regulator, Carburetor and internal parts |
| Air Induction System | Air cleaner, Intake manifold |
| Ignition System | Spark plug and parts, Magneto ignition system |
| Exhaust System | Exhaust manifold, catalytic converter |
| Miscellaneous Parts | Tubing, Fittings, Seals, Gaskets, and Clamps associated with these listed systems. |
| Evaporative Emissions | Fuel Tank, Fuel Cap, Fuel Line (for liquid fuel and fuel vapors), Fuel Line Fittings, Clamps, Pressure Relief Valves, Control Valves, Control Solenoids, Electronic Controls, Vacuum Control Diaphragms, Control Cables, Control Linkages, Purge Valves, Gaskets, Vapor Hoses, Liquid/Vapor Separator, Carbon Canister, Canister Mounting Brackets, Carburetor Purge Port Connector |

TO OBTAIN WARRANTY SERVICE:

You must take your CPE engine or the product on which it is installed, along with your warranty registration card or other proof of original purchase date, at your expense, to any Champion Power Equipment dealer who is authorized by Champion Power Equipment, Inc. to sell and service that CPE product during his normal business hours. Alternate service locations defined in Section (3)(f.) above must be approved by CPE prior to service. Claims for repair or adjustment found to be caused solely by defects in material or workmanship will not be denied because the engine was not properly maintained and used.

If you have any questions regarding your warranty rights and responsibilities, or to obtain warranty service, please write or call Customer Service at Champion Power Equipment, Inc.

**Champion Power Equipment, Inc.
12039 Smith Ave.
Santa Fe Springs, CA 90670
1-877-338-0999
Attn.: Customer Service
tech@championpowerequipment.com**