

Table of Contents

Introduction	1	Storage	16
Portable Power Generator	1	Engine Storage	16
Accessories.....	1	Generator Storage.....	16
This Booklet.....	1	Specifications	17
Manual Conventions	2	Engine Specifications.....	17
Safety Rules	3	Generator Specifications.....	17
Controls and Features.....	6	Battery.....	17
Generator.....	6	Fuel.....	17
Power Panel.....	7	Oil.....	17
Parts Included	8	Spark Plugs	17
Assembly	9	Valve Clearance.....	17
Remove the Generator from the Shipping		Parts Diagram	18
Carton	9	Engine.....	18
Install the Wheel Kit.....	9	Power Panel.....	19
Install the Support Leg.....	9	Generator	20
Install the Handle.....	9	Parts List	21
Connect the Battery.....	9	Troubleshooting	26
Optional: Install the Spark Arrester.....	10	Warranty	27
Add Engine Oil	10	Warranty Qualifications	27
Connect LPG cylinder.....	10	Repair/Replacement Warranty	27
Grounding.....	11	Do not return the unit to the place of	
Operation	12	purchase.....	27
Generator Location.....	12	Warranty Exclusions.....	27
Grounding.....	12	Limits of Implied Warranty and	
Starting the Engine.....	12	Consequential Damage	27
Connecting Electrical Loads.....	12	Contact Information	27
Stopping the Engine	12	Address.....	27
Do Not Overload Generator	12	Customer Service	27
Capacity.....	12	Technical Service.....	27
Power Management	13	Notes	31
Wattage Reference Chart.....	13		
Maintenance	14		
Engine Maintenance.....	14		
Oil.....	14		
Spark Plugs	14		
Air Filter	14		
Spark Arrester	15		
Cleaning	15		
Adjustments	15		
Maintenance Schedule.....	15		
Generator Maintenance.....	15		

Introduction

Congratulations on your purchase of a Champion Power Equipment generator. CPE designs and builds generators to strict specifications. With proper use and maintenance, this generator will bring years of satisfying service.

Portable Power Generator

This unit is a liquefied petroleum gas (LPG) engine driven, alternating current (AC) generator. It is designed to supply electrical power for lighting, appliances, tools and similar equipment.

Accessories

Champion Power Equipment manufactures and sells accessories designed to help you get the most from your purchase. To find out more about our covers, power cables and storm kits, please visit our web site at

www.championpowerequipment.com

This Booklet

Every effort has been made to ensure the accuracy and completeness of the information in this manual. We reserve the right to change, alter and/or improve the product and this document at any time without prior notice.

Record the model and serial numbers as well as date and place of purchase for future reference. Have this information available when ordering parts and when making technical or warranty inquiries.

Champion Power Equipment Support
(877) 338-0999
Model Number
C71350E
Serial Nuber
Date of Purchase
Purchase Location

Manual Conventions

Manual Conventions

This manual uses the following symbols to help differentiate between different kinds of information. The safety symbol is used with a key word to alert you to potential hazards in operating and owning power equipment.

Follow all safety messages to avoid or reduce the risk of serious injury or death.

DANGER

DANGER indicates an imminently hazardous situation which, if not avoided, *will* result in death or serious injury.

WARNING

WARNING indicates a potentially hazardous situation which, if not avoided, *could* result in death or serious injury.

CAUTION

CAUTION indicates a potentially hazardous situation which, if not avoided, *may* result in minor or moderate injury.

CAUTION

CAUTION used without the safety alert symbol indicates a potentially hazardous situation which, if not avoided, *may* result in property damage.

NOTE

If you have questions regarding your generator, we can help. Please call our help line at (877) 338-0999.

Safety Rules

WARNING

Read this manual thoroughly before operating your generator. Failure to follow instructions could result in serious injury or death.

WARNING

The engine exhaust from this product contains chemicals known to the state of California to cause cancer, birth defects, or other reproductive harm.

DANGER

Generator exhaust contains carbon monoxide, a colorless, odorless, poison gas. Breathing carbon monoxide will cause nausea, dizziness, fainting or death.

Operate generator outdoors only in a well ventilated area
DO NOT operate the generator inside any building, enclosure or compartment, including the generator compartment of a recreational vehicle. DO NOT allow exhaust fumes to enter a confined area through windows, doors, vents or other openings.

DANGER

Rotating parts can entangle hands, feet, hair, clothing and/or accessories.

Traumatic amputation or severe laceration can result.

Keep hands and feet away from rotating parts.
Tie up long hair and remove jewelry.
Operate equipment with guards in place.
DO NOT wear loose-fitting clothing, dangling drawstrings or items that could become caught.

DANGER

Generator produces powerful voltage.

DO NOT touch bare wires or receptacles.
DO NOT use electrical cords that are worn, damaged or frayed.
DO NOT operator generator in wet weather.
DO NOT allow children or unqualified persons to operate or service the generator
Use a ground fault circuit interrupter (GFCI) in damp areas and areas containing conductive material such as metal decking.
Use approved transfer equipment to isolate generator from your electric utility and Notify your utility company before connecting your generator to your power system.

WARNING

Sparks can result in fire or electrical shock.

When servicing the generator:

Disconnect the spark plug wire and place it where it cannot contact the plug.
DO NOT check for spark with the plug removed.
Use only approved spark plug testers.

WARNING

Running engines produce heat.
Severe burns can occur on contact.
Combustible material can catch fire on contact.

DO NOT touch hot surfaces.
Avoid contact with hot exhaust gases.
Allow equipment to cool before touching.
Maintain at least three feet of clearance on all sides to ensure adequate cooling.
Maintain at least five feet of clearance from combustible materials.

Safety Rules

DANGER

Propane (LPG) is highly flammable and explosive.

Fire or explosion can cause severe burns or death if the gas is ignited.

Before starting the generator

Turn the generator off.

Inspect your LPG tank for damage or leaks.

Attach only approved tanks that have been properly filled by an approved station.

DO NOT light or smoke cigarettes.

Replace the hose at the first sign of a leak or if age-cracking becomes apparent.

When starting the generator

DO NOT attempt to start a damaged generator.

Make certain that the LPG tank, air filter, spark plug, fuel lines and exhaust system are properly in place.

Make certain that the generator resting firmly on level ground.

When operating the generator:

DO NOT move or tip the generator during operation.

DO NOT tip the generator or allow oil to spill.

When transporting or servicing the generator:

Make certain that the LPG tank is disconnected and properly shut off.

Disconnect the spark plug wire.

When storing the generator:

Store away from sparks, open flames, pilot lights, heat and other sources of ignition.

WARNING

Rapid retraction of the starter cord will pull hand and arm towards the engine faster than you can let go.

Unintentional startup can result in entanglement, traumatic amputation or laceration.

Broken bones, fractures, bruises or sprains could result.

When starting engine, pull the starter cord slowly until resistance is felt and then pull rapidly to avoid kickback.

DO NOT start or stop the engine with electrical devices plugged in.

WARNING

The battery contains acid. Acid is strongly corrosive.

Alkaline fluid from the battery is strongly corrosive. Flush the eyes or the skin immediately with clean water if they come into contact with battery fluid. Contact your doctor immediately.

DO NOT use the battery if it is leaking, or abnormal in any other way.

DO NOT strike or drop the battery. It may cause damage to the battery.

Never dispose of the battery in a fire. Leakage or explosion will result.

Keep the positive and negative polarities separated at all times to avoid short circuiting the battery.

Never disassemble the battery.

DO NOT reverse the battery's positive and negative polarities.

DO NOT directly connect the battery to a direct power source with high voltage, like the cigarette lighter in a car. High voltage equipment will damage the battery immediately.

Store the battery in a dry cool place. DO NOT use, store or expose the battery in high temperature situations, as in the direct sunlight, inside automobiles during hot weather, directly in front of a heater, etc.

Be sure to turn off the equipment and remove the battery after use.

CAUTION

Exceeding the generator's running capacity can damage the generator and/or electrical devices connected to it

DO NOT overload the generator.

Start the generator and allow the engine to stabilize before connecting electrical loads.

Connect electrical equipment in the off position, and then turn them on for operation.

Turn electrical equipment off and disconnect before stopping the generator.

DO NOT tamper with the governed speed.

DO NOT modify the generator in any way.



CAUTION

Improper treatment or use of the generator can damage it, shorten its life and void your warranty.

Use the generator only for intended uses.
Operate only on level surfaces.
DO NOT expose generator to excessive moisture, dust, or dirt.
DO NOT allow any material to block the cooling slots.
If connected devices overheat, turn them off and disconnect them from the generator.
DO NOT use the generator if:
 Electrical output is lost
 Equipment sparks, smokes or emits flames
 Equipment vibrates excessively

Controls and Features

Controls and Features

Read this owner's manual before operating your generator. Familiarize yourself with the location and function of the controls and features. Save this manual for future reference.

Generator

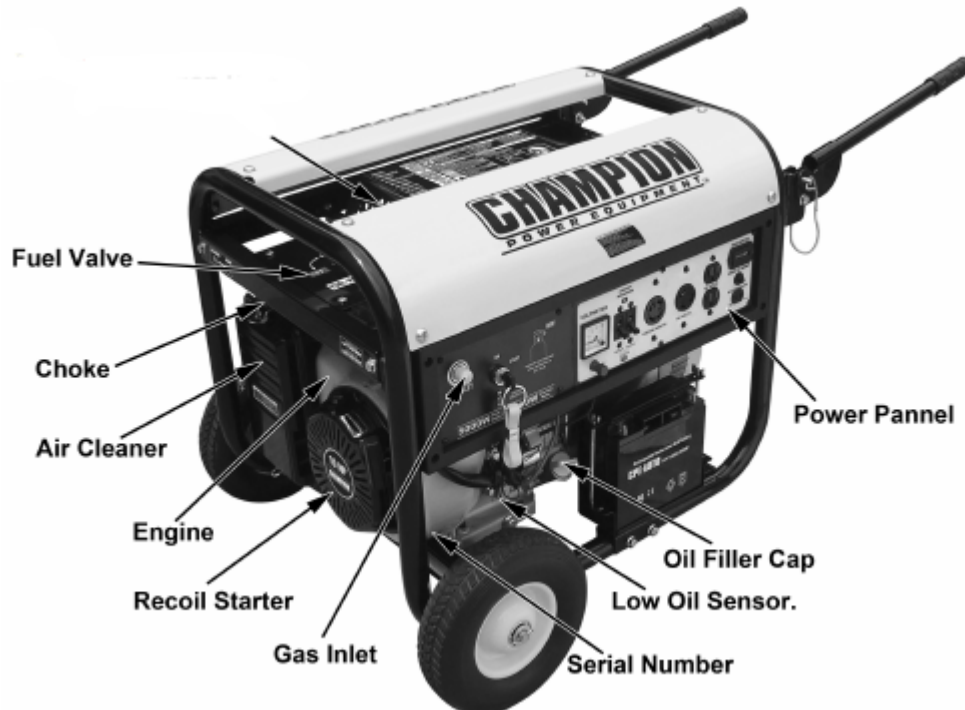

Gas Inlet – Nipple for LPG connection.

Oil Filler Cap – Check and fill engine oil level.

Engine – 10 HP OHV engine.

Air Cleaner – Protects the engine by filtering dust and debris from the intake air.

Choke – Used to start the engine

Recoil Starter – Used to start the engine

Fuel Valve – Turn this valve to the “On” position to supply fuel to the engine.

Battery – Used to start the engine.

Serial Number – Please have this number available when calling for assistance.

Low Oil Sensor – Senses the level of oil in the crankcase and shuts the engine down if the level falls too low.

Power Panel – See “Power Panel”

Power Panel

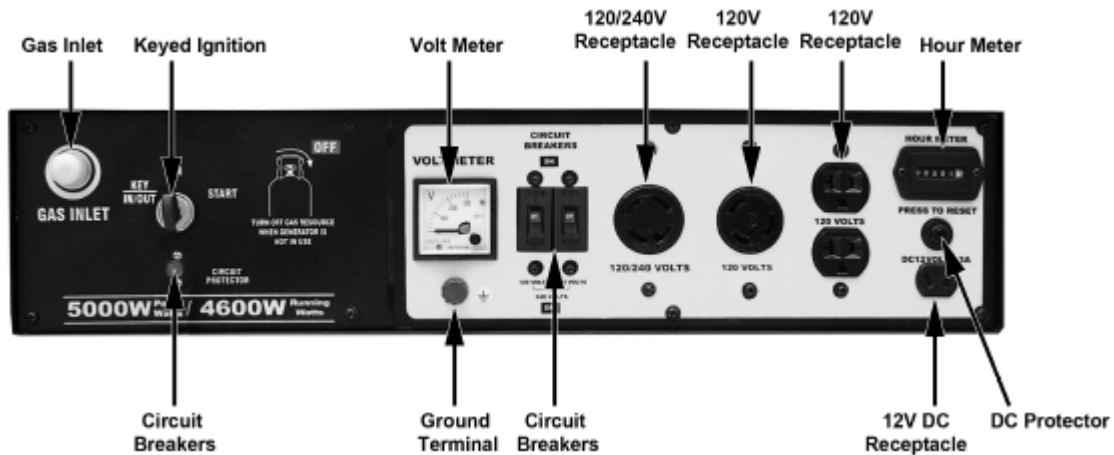

Receptacles

120/240 V 30 A Twist-Lock – protected by a 22 A circuit breaker on each 120 Volt leg of the receptacle. This receptacle powers 240 Volt AC, 60 Hz, single phase loads requiring up to 19 A or 4600 Watts of power. If an L14-30P plug is wired for only one 120 Volt leg (3-wire connection) then this receptacle powers 120 Volt AC, 60 Hz, single phase loads requiring up to 22 A or 2600 Watts of power.

120 V 30 A Twist-Lock – protected by a 22 A circuit breaker. This receptacle powers 120 Volt AC, 60 Hz, single phase loads requiring up to 22 Amps or 2600 watts of power.

120 V 20 A Duplex – these receptacles are protected by a 22 A circuit breaker. Use each receptacle to operate 120 Volt AC, single phase, 60 Hz loads requiring up to 20 A or 2400 Watts of power, not to exceed 22 A or 2600 Watts for the combined loads of these two receptacles.

12 V 8.3 A DC – this receptacle allows you to recharge a 12 Volt automotive or utility style storage battery with the battery charge

cables provided. This receptacle cannot charge 6 Volt batteries and cannot be used to crank an engine. It is not recommended for charging deep cycle batteries. Do not charge batteries for extended periods of time without checking.

Voltmeter – Displays the output voltage of the generator.

Circuit Breakers – Protects the generator against electrical overload.

Hour Meter – Records the cumulative number of hours the generator has been in use.

Keyed Ignition – Turn the key to the “Start” position to start the generator. Turn to the “Off” position to turn off the generator.

Ground Terminal – Consult an electrician for local grounding regulations.

Controls and Features

Parts Included

Your C71350E LPG-Powered Generator ships with the following parts:



6 foot Battery Cable

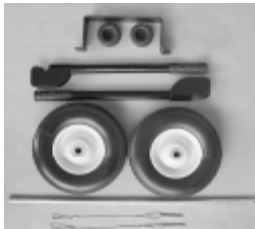

Wheel Kit

Axle	1 piece
10" Solid Wheel	2 pieces
Vibration Mounts	2 pieces
Handle Assembly	1 set
Handle Lock Pins	2 pieces



Bolt Kit

Wheel Retaining Pins	2 pieces
Flat Washers	2 pieces
"O" Washers	2 pieces
Plastic Flat Washers	4 pieces
Cap Screws and Nuts	6 sets

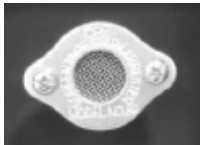

Spark Arrester Kit

Spark Arrester	1 piece
Cover Plate	1 piece
Screws, Lock Washers	2 pieces



Oil Funnel	1 piece
Wrench	1 piece
Spark Plug Socket	1 piece



6.5 foot Gas Hose and Regulator Assembly

Assembly

Your generator requires some assembly. This unit ships from our factory without oil. It must be properly serviced with fuel and oil before operation.

If you have any questions regarding the assembly of your generator, call our help line at (877) 338-0999. Please have your serial number and model number available.

Remove the Generator from the Shipping Carton

1. Set the shipping carton on a solid, flat surface.
2. Remove everything from the carton except the generator.
3. Carefully cut each corner of the box from top to bottom. Fold each side flat on the ground to provide a surface area to install the wheel kit and support leg.

Install the Wheel Kit

CAUTION

The wheel kit is not intended for over-the-road use.

You will need the following tools to install the wheels:

- 12 mm wrench
 - Socket wrench with a 12 mm socket
 - Pliers
1. Before adding oil to the engine, tip the generator slowly so that the engine side is up.
 2. Slide the axle through both mounting brackets.
 3. Place an “o” washer onto the axle and then slide a wheel onto the axle. Make certain that the valve stem is facing outward.
 4. Place a flat washer on the end.
 5. Install the cotter pin through the hole on the end of the axle.
 6. Carefully bend the legs of the cotter pin back around the axle.

7. Repeat steps 3-6 to attach the second wheel.

Install the Support Leg

1. Attach the rubber vibration mount to the support leg with a cap screw (M8x20) and lock nut (M8).
2. Attach the support leg to the generator frame with cap screws (M8x30) and lock nuts (M8).
3. Tip the generator slowly so that it rests on the wheels and support leg.

Install the Handle

1. Line up the bottom hole on the handle with the bottom hole on the frame.
2. Place a plastic washer on the cap screw (M8x50) and thread through the frame and handle.
3. Place a plastic washer and lock nut (M8) on the end of the bolt and fasten securely. DO NOT over tighten the lock nut.
4. Wrap the retention cord around the frame near the handle. Thread the lock pins through the loop on the retention cord.
5. Repeat steps 1-4 for the second handle.

Connect the Battery

1. Place the battery in the battery mounting channel.
2. Hook one J-bolt through the hole on the bottom left side of the battery mounting channel.
3. Place a washer on the J-bolt and fasten loosely with the wing nut.
4. Repeat steps 1-2 for the right side of the battery mounting channel.
5. Tighten both wing nuts evenly and securely.
6. Remove the protective cover from the red battery lead.
7. Attach the red lead to the red terminal on the battery with the cap screw (M6x20) and secure with the lock washer (M6)
8. Repeat steps 5-6 for the black battery lead.

Assembly

Optional: Install the Spark Arrester

Insert the spark arrester screen into the muffler outlet. Secure the spark arrester by placing the cover plate over the end of the screen, with the lettering facing outward. Secure the cover plate with the two screws and lock washers provided with the spark arrester kit.

Add Engine Oil

CAUTION

DO NOT attempt to crank or start the engine before it has been properly filled with the recommended type and amount of oil. Damage to the generator as a result of failure to follow these instructions will void your warranty.

1. Place the generator on a flat, level surface.
2. Remove oil fill cap/dipstick to add oil.
3. Add 1.16 qt (1.1 L) of oil and replace oil fill cap/dipstick.
4. Check engine oil level daily and add as needed.

CAUTION

The engine is equipped with a low-oil-shutoff and the will stop when the oil level in the crankcase falls below the threshold level.

NOTE

Check oil often during the break-in period. Refer to the Maintenance section for recommended service intervals.

NOTE

The generator rotor has a sealed, pre-lubricated ball bearing that requires no additional lubrication for the life of the bearing.

Connect LPG cylinder

1. Turn off the fuel valve on the generator.
2. Attach the LPG connector to the gas inlet.
3. Open the manual shutoff valve on the LPG cylinder.
4. Open the fuel valve on the generator.

WARNING

Liquefied Petroleum Gas is extremely flammable and explosive.

If there is a strong smell of gas:
Close off the gas supply at the cylinder.
Use soapy water which will produce a large bubble at the point of any leak, to check the cylinder valve, connections and the generator.
Do not smoke or light a cigarette.
Contact a qualified technician to inspect and repair the LPG system.

CAUTION

Use approved LP cylinders equipped with an OPD (overfilling prevention device) valve.

Always keep the cylinder in a vertical position with the valve on top and installed at ground level on a flat surface
Cylinders must not be installed near any heat source and should not be exposed to sun, rain, dust and heat.
Regulators to be used on the cylinders must be of the diameter as the cylinder valve.
Regulators should always be in the off position when the cylinder is not in use.

Grounding

Your generator must be properly connected to an appropriate ground to help prevent electric shock.



WARNING

Failure to properly ground the generator can result in electric shock.

A ground terminal connected to the frame of the generator has been provided on the power panel. For remote grounding, connect a length of heavy gauge (12 AWG minimum) copper wire between the generator ground terminal and a copper rod driven into the ground. We strongly recommend that you consult with a qualified electrician to ensure compliance with local electrical codes.

Operation

Generator Location

Please consult your local authority. In some areas, generators must be registered with the local utility.

Generators used at construction sites may be subject to additional rules and regulations. This generator must have at least five feet of clearance from combustible material. Leave at least three feet of clearance on all sides of the generator to allow for adequate cooling, maintenance and servicing. Place the generator in a well-ventilated area. DO NOT place the generator near vents or intakes where exhaust fumes could be drawn into occupied or confined spaces. Carefully consider wind and air currents when positioning generator.

Grounding

The generator system ground connects the frame to the ground terminals on the power panel. The system ground is connected to the AC neutral wire.

Starting the Engine

1. Make certain the generator is on a flat, level surface.
2. Disconnect all electrical loads from the generator. Never start or stop the generator with electrical devices plugged in or turned on.
3. Open the manual shutoff valve on the LPG cylinder.
4. Turn the fuel valve to the "On" position.
5. Move the choke lever to the "Choke" position.
6. ELECTRIC START: Turn the ignition key to the "Start" position and hold until engine starts. If the engine fails to start within five seconds, release the key and wait at least ten seconds before attempting to start the engine again.
7. RECOIL START: Pull the starter cord slowly until resistance is felt and then pull rapidly
8. As engine warms up, move the choke lever to "Run".



NOTE

If the engine starts but does not run, make certain that the generator is on a flat, level surface. The engine is equipped with a low oil sensor that will prevent the engine from running when the oil level falls below a critical threshold.

Connecting Electrical Loads

1. Let the engine stabilize and warm up for a few minutes after starting
2. Plug in and turn on the desired 120 and/or 240 Volt AC single phase, 60 Hz electrical loads.

DO NOT connect 3-phase loads to the generator.

DO NOT connect 50 Hz loads to the generator.

DO NOT overload the generator.

Stopping the Engine

1. Turn off and unplug all electrical loads. Never start or stop the generator with electrical devices plugged in or turned on.
2. Let the generator run at no-load for several minutes to stabilize internal temperatures of the engine and generator.
3. Turn the ignition switch to the "Off" position.
4. Turn the fuel valve to the "Off" position.
5. Close the OPD valve on the LPG cylinder.

Do Not Overload Generator

Capacity

Follow these simple steps to calculate the running and starting watts necessary for your purposes.

1. Select the electrical devices you plan on running at the same time.
2. Total the running watts of these items. This is the amount of power you need to keep your items running.
3. Identify the highest starting wattage of all devices identified in step 1. Add this number to the number calculated in step

2. Surge wattage is the extra burst of power needed to start some electric driven equipment. Following the steps listed under “Power Management” will guarantee that only one device will be starting at a time.

Power Management

Use the following formula to convert voltage and amperage to watts:

$$\text{Volts} \times \text{Amps} = \text{Watts}$$

To prolong the life of your generator and attached devices, follow these steps to add electrical load:

1. Start the generator with no electrical load attached.
2. Allow the engine to run for several minutes to stabilize.
3. Plug in and turn on the first item. It is best to attach the item with the largest load first.
4. Allow the engine to stabilize.
5. Plug in and turn on the next item.
6. Allow the engine to stabilize.
7. Repeat steps 5-6 for each additional item.

NOTE

Never exceed the generator capacity when adding loads.

Wattage Reference Chart

Use the chart to determine approximate wattage requirements for your equipment.

NOTE

Starting watts can exceed three times the running watts. The values in the following table are approximate. Refer to your tool or appliance for actual wattage consumption.

Item	Running Watts	Starting Watts
Essentials		
Light Bulb 100W	100	
Refrigerator/Freezer	1200	2400
Freezer	500	500
Sump Pump	600	1800
Well Pump 1 HP	2000	4000
Water Heater	4000	
Security System	180	
AM/FM Radio	300	
Garage Door Opener 1/2 HP	500	600
Battery Charger 12V DC	110	
Heating/Cooling		
Air Conditioner 12000 BTU	1700	2500
Fan	300	600
Furnace Fan 1/3 HP	1200	2000
Home Appliances		
Microwave 1000W	1000	
Electric Range - One Element	1500	
Electric Skillet	1250	
Coffee Maker	1500	
Clothes Washer	1200	
Entertainment		
CD/DVD Player	100	
VCR	100	
Stereo Receiver	450	
Television 27"	500	
PC with 15" Monitor	800	
Job Site		
Belt Sander 3"	1000	1500
Bench Grinder 6"	700	1500
Circular Saw	1500	1500
Compressor 1 1/2 HP	2500	2500
Edge Trimmer	500	500
Hand Drill 1/2"	1000	1000
Lawn Mower	1200	1800
Paint Sprayer	600	1200
Table Saw	2000	2000

Maintenance

Maintenance

The owner/operator is responsible for all periodic maintenance.

WARNING

Never operate a damaged or defective generator.

WARNING

Tampering with the factory set governor will void your warranty.

WARNING

Improper maintenance will void your warranty.

Complete all scheduled maintenance in a timely manner. Correct any issue before operating the generator.

NOTE

For service or parts assistance, contact our help line at (877) 338-0999.

Engine Maintenance

To prevent accidental starting, remove and ground spark plug wire before performing any service.

Oil

Change oil when the engine is warm. Refer to the oil specification to select the proper grade of oil for your operating environment.

1. Remove the oil drain plug with a 15 mm socket and extension.
2. Allow the oil to drain completely.
3. Replace the drain plug.
4. Remove oil fill cap/dipstick to add oil.
5. Add 1.16 qt (1.1 L) of oil and replace oil fill cap/dipstick.

6. Dispose of used oil at an approved waste management facility.

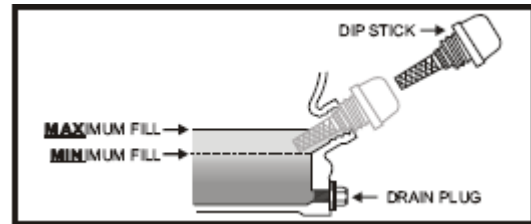

Spark Plugs

CAUTION

Allow the engine to cool before removing the spark plug.

1. Remove the spark plug cable from the spark plug.
2. Use the spark plug tool that shipped with your generator to remove the plug.
3. Inspect the electrode on the plug. It must be clean and not worn to produce the spark required for ignition.
4. Make certain the spark plug gap is 0.7 - 0.8mm (0.028 - 0.031 in.).
5. Refer to the spark plug recommendation chart when replacing the plug.
6. Carefully thread the plug into the engine.
7. Use the spark plug tool to firmly install the plug.
8. Attach the spark plug wire to the plug.

Air Filter

1. Remove the snap-on cover holding the air filter to the assembly.
2. Remove the foam element.
3. Wash in liquid detergent and water. Squeeze thoroughly dry in a clean cloth.
4. Saturate in clean engine oil.
5. Squeeze in a clean, absorbent cloth to remove all excess oil.
6. Place the filter in the assembly.
7. Reattach the air filter cover and snap in place.

Spark Arrester

1. Allow the engine to cool completely before servicing the spark arrester.
2. Remove the two screws holding the cover plate which retains the end of the spark arrester to the muffler.
3. Remove the spark arrester screen.
4. Carefully remove the carbon deposits from the spark arrester screen with a wire brush.
5. Replace the spark arrester if it is damaged.
6. Position the spark arrester in the muffler and attach with the two screws.

Cleaning

 CAUTION
DO NOT spray engine with water.
Water can contaminate the fuel system.

Use a damp cloth to clean exterior surfaces of the engine.

Use a soft bristle brush to remove dirt and oil.

Use an air compressor (25 PSI) to clear dirt and debris from the engine.

Adjustments

The air-fuel mixture is not adjustable. Tampering with the governor can damage your generator and your electrical devices and will void your warranty. CPE recommends that you contact our service line at (877) 338-0999 for all other service and/or adjustment needs.

Maintenance Schedule

Follow the service intervals indicated in the schedule below.

Service your generator more frequently when operating in adverse conditions. Contact our help line at (877) 338-0999 to locate the nearest Champion Power Equipment certified service dealer for your generator or engine maintenance needs.

Every 8 hours or daily
Check oil level
Clean around air intake and muffler
First 5 Hours
Change oil
First 10 hours
Check/Adjust Valve Clearance *
Every 50 hours or every season
Clean air filter
Change oil if operating under heavy load or in hot environments
Every 100 hours or every season
Change oil
Clean/Adjust spark plug
Check/Adjust valve clearance *
Clean spark arrester
Every 3 years
Replace fuel line *
Inspect LPG cylinder *

* To be performed by knowledgeable, experienced owners or Champion Power Equipment certified service dealers

Generator Maintenance

Make certain that the generator is kept clean and stored properly. Only operate the unit on a flat, level surface in a clean, dry operating environment. DO NOT expose the unit to extreme conditions, excessive dust, dirt, moisture or corrosive vapors.

 CAUTION
DO NOT use a garden hose to clean the generator.
Water can enter the generator through the cooling slots and damage the generator windings.

Use a damp cloth to clean exterior surfaces of the generator.

Use a soft bristle brush to remove dirt and oil.

Use an air compressor (25 PSI) to clear dirt and debris from the generator.

Inspect all air vents and cooling slots to ensure that they are clean and unobstructed.

Storage

Storage

The generator should be started at least once every 14 days and allowed to run for at least 20 minutes. For longer term storage, please follow these guidelines.

Engine Storage

1. Allow the engine to cool completely before storage.
2. Clean the engine according to the instructions in the Maintenance section.
3. Turn off the fuel valve on the generator.
4. Close the manual shutoff valve on the LPG cylinder and disconnect from the generator.

5. Change the oil.
6. Remove the spark plug and pour about 1/2 ounce of oil into the cylinder. Crank the engine slowly to distribute the oil and lubricate the cylinder.
7. Reattach the spark plug.

Generator Storage

1. Allow the generator to cool completely before storage.
2. Turn off the fuel supply at the fuel valve.
3. Clean the generator according to the instructions in the Maintenance section.
4. Store the unit in a clean, dry area, out of direct sunlight.

Specifications

Engine Specifications

Engine 10 HP OHV
EPA certified

Generator Specifications

Running Wattage 4600 Watts
Starting Wattage 5000Watts
AC Load 120/240 V
Phase Single
Frequency 60 Hz
Fuel Capacity Liquefied Petroleum Gas
Weight 229.3 lbs.
Height 21 inches
Width 27 inches
Length 20.5 inches

Battery

Your generator comes equipped with a 12V 18Ah Nominal Capacity Rechargeable Sealed Lead-Acid (SLA) battery.

Fuel

Use only an approved LPG cylinder equipped with an OPD valve.
Flow rate: ≥ 2.0 kg/hr
Outlet pressure: $2.8 \text{ kpa} \pm 0.5 \text{ kpa}$

Oil

Oil capacity is 1.16 qt (1.1 L).

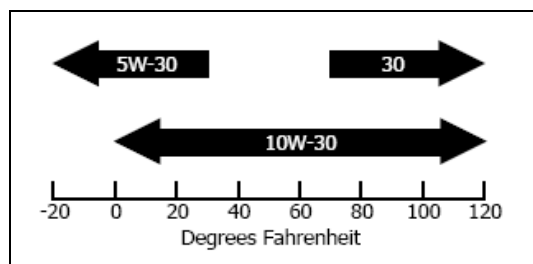

Spark Plugs

Your generator comes equipped with a 3/4" long reach plug (14mm).

Use only "Green Power" brand replacement LPG spark plugs.

CAUTION

Failure to use the proper plug may damage your engine and will void your warranty.

Make certain the spark plug gap is 0.7 - 0.8mm (0.028 - 0.031 in.).

Valve Clearance

Intake 0.06-0.08mm (0.0016 - 0.0024 in.)
Exhaust 0.08-0.10mm (0.0024 - 0.0031 in.)

Specifications

Parts Diagram

Engine

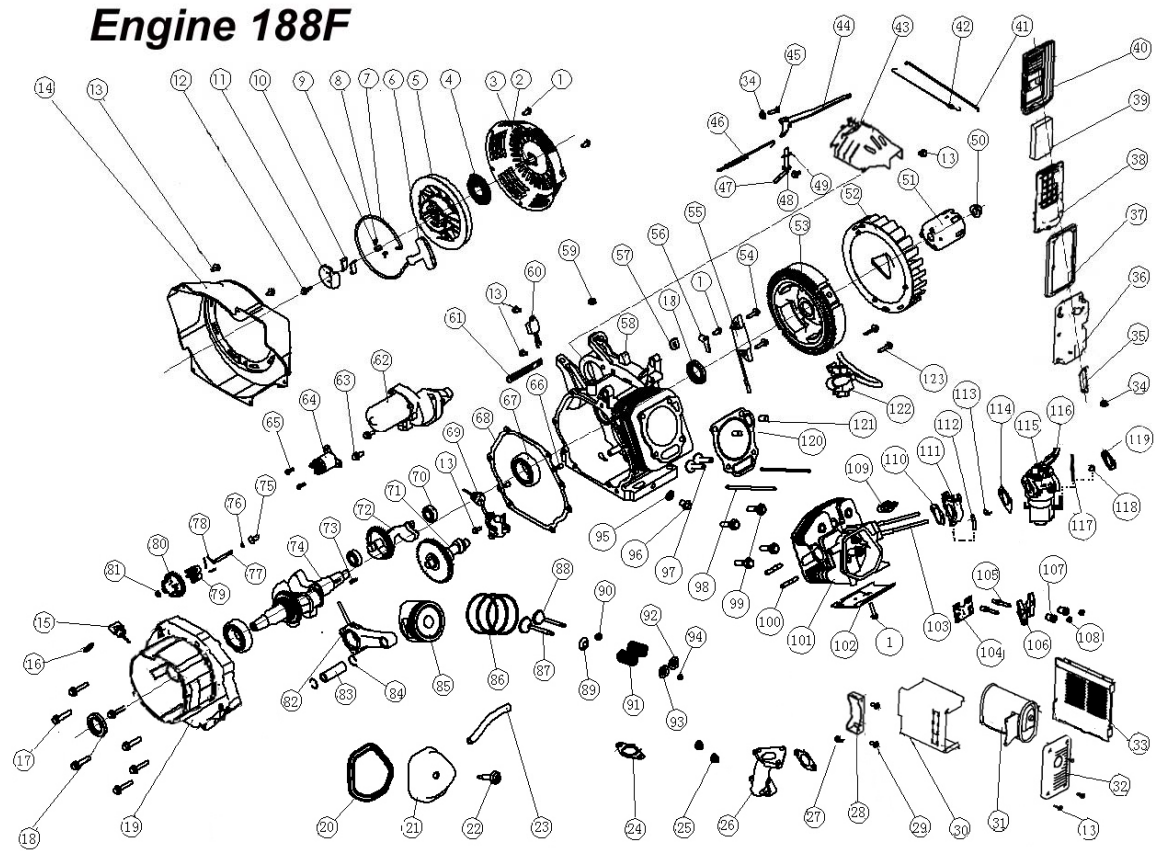

Power Panel

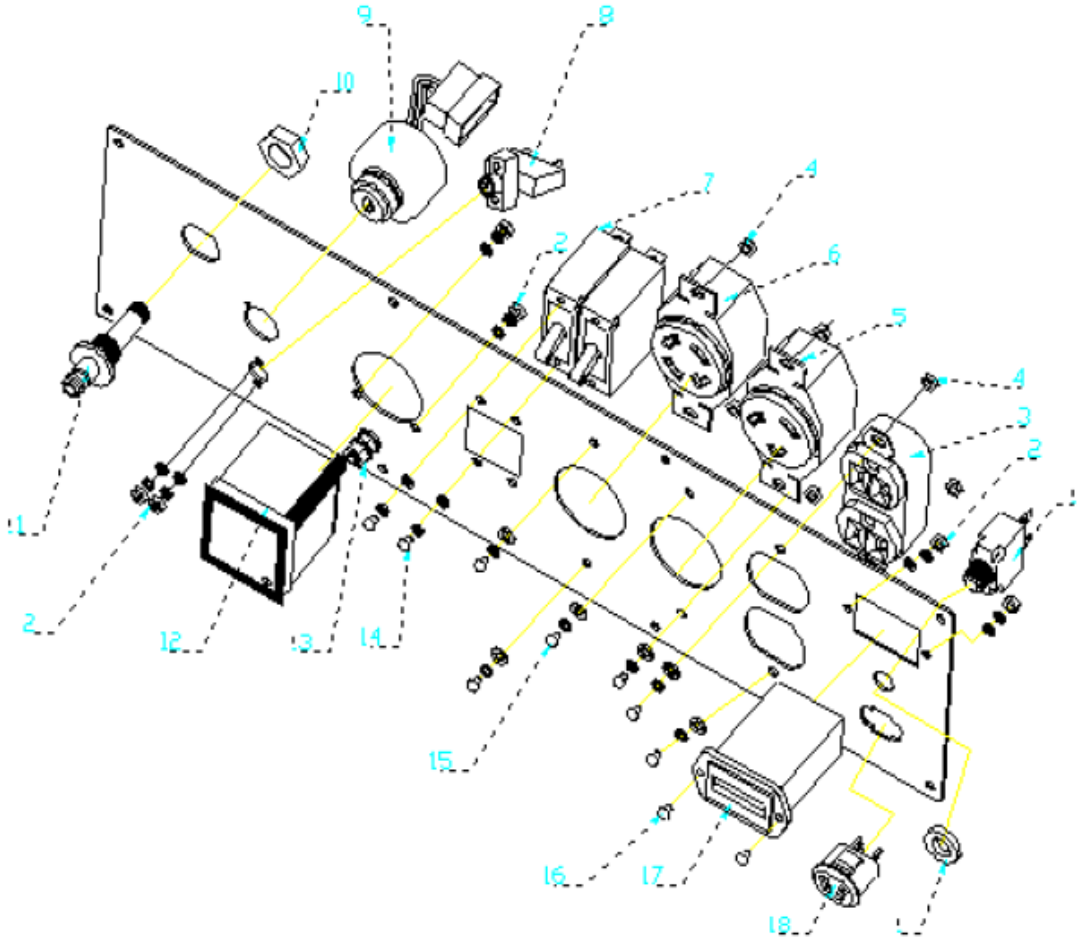

Specifications

Generator

Illustration Drawing of 5kw-T2 Generator Set
(with Recoil&Electric Starter)

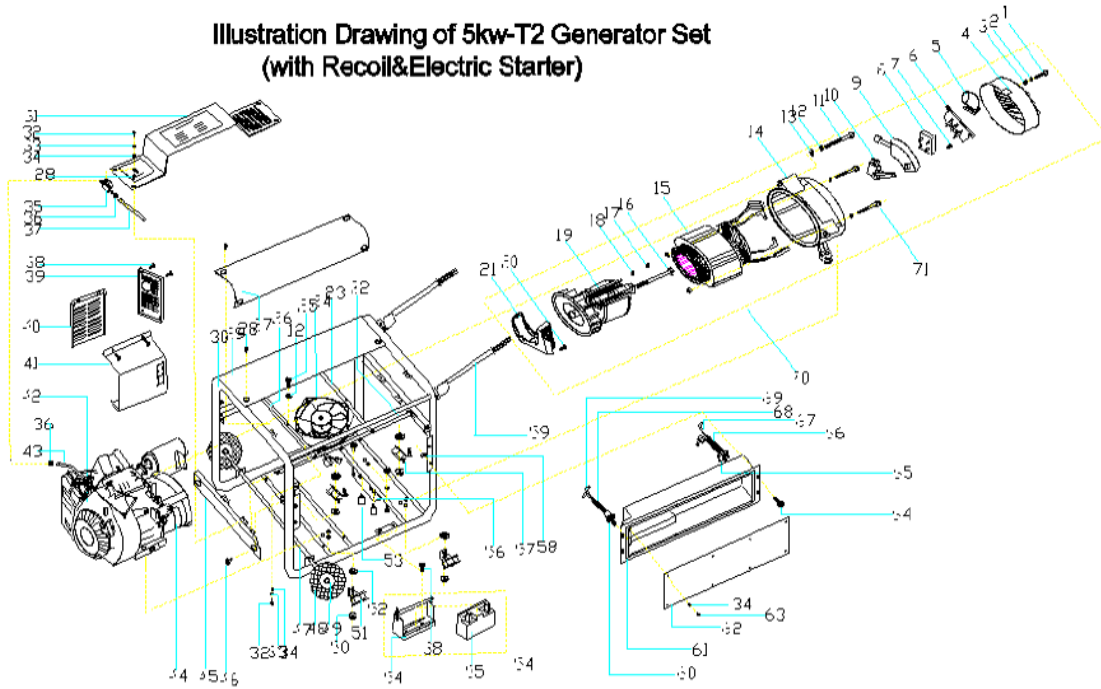

Parts List

No	Item #	Description	Qty
Engine 188F			
1	GB/T5789-86	Flange bolt M6×8	3
2	GF2.011105.01.13-1	Recoil Starter Case Cover	1
3	GF2.011105.01.13-2	Recoil Starter Brace	1
4	GF2.011105.01.13-3	Starter Return Spring	1
5	GF2.011105.01.13-4	Recoil Starter Reel	1
6	GF2.011105.01.13-5	Recoil Starter Knob	1
7	GF2.011105.01.13-6	Recoil Starter Rope	1
8	GF2.011105.01.13-7	Ratchet Spring	2
9	GF2.011105.01.13-8	Ratchet Guide Spring	1
10	GF2.011105.01.13-9	Ratchet Starter	2
11	GF2.011105.01.13-10	Ratchet Guide	1
12	GF2.011105.01.13-11	Ratchet Guide Bolt	1
13	GB5789-86	Flange Bolt M6×12	17
14	GF2.011105.01.13-02	Fan Cover Complete	1
15	GF2.011105.01.01-1	Oil Filler Cap	1
16	GF2.011105.01.01-2	Oil Filler Cap Packing	1
17	GB/T5789-86	Flange Bolt M8×40	7
18	GF2.011105.01.01-01	Oil Seal	2
19	GF2.011105.01.01-3	Crankcase Cover	1
20	GF2.011105.01.02-1	Head Cover Packing	1
21	GF2.011105.01.02-01	Head Cover Complete	1
22	GF2.011105.01.02-02	Head Cover Bolt Complete	1
23	GF2.011105.01.00-4	Tube	1
24	GF2.011105.01.12-1	Ex. Pipe Gasket	2
25	GB/T41-86	Nut M8	2
26	GF2.011105.01.12-2	Ex, Pipe	1
27	GB/T5789-86	Bolt M8×12	2
28	GF2.011105.02.00-1	Muffler Stay	1
29	GB/T5789-86	Bolt M8×16	2
30	GF2.011105.01.00-3	Muffler Outer Protector	1
31	GF2.011105.01.12-00	Muffler	1
32	GF2.011105.01.00-2	Heat Shield	1
33	GF2.011105.01.00-1	Muffler Inner Protector	1
34	GB/T6177-86	Nut M6	3
35	GF2.011105.01.00-5	Air Cleaner Stay	1
36	GF2.011105.01.11-01	Air Cleaner Case Complete	1
37	GF2.011105.01.11-1	Air Cleaner Seal	1
38	GF2.011105.01.11-2	Air Cleaner Grid	1
39	GF2.011105.01.11-3	Air Cleaner Element	1
40	GF2.011105.01.11-02	Air Cleaner Cover Complete	1
41	GF2.011105.01.10-1	Governor Rod	1
42	GF2.011105.01.10-2	Spring	1
43	GF2.011105.01.00-01	Control Assembly	1
44	GF2.011105.01.10-3	Governor Arm	1
45	GF2.011105.01.10-4	Governor Arm Bolt	1
46	GF2.011105.01.10-5	Governor Spring	1
47	GF2.011105.01.10-6	Governor Arm Shaft	1
48	GF2.011105.01.10-7	Washer 8.2×17×0.8	1
49	GF2.011105.01.10-8	Pin Clip	1
50	GF2.011105.01.00-6	Nut	1
51	GF2.011105.01.00-7	Starter Hub	1
52	GF2.011105.01.14-1	Cooling Fan	1

Specifications

No	Item #	Description	Qty
53	GF2.011105.01.14-01	Flywheel Complete	1
54	GB/T5789-86	Flange bolt M6×29	2
55	GF2.011105.01.15-02	Ignition coil	1
56	GF2.011105.01.00-8	Wire Flat	1
57	GF2.011105.01.00-9	Packing	1
58	GF2.011105.01.01-5	Crankcase Assembly	1
59	GF2.011105.01.10-9	Oil Seal	1
60	GF2.011105.01.15-03	Oil alert unit	1
61	GF2.011105.01.00-10	Wire Clip	1
62	GF2.011105.01.15-04	Start Motor	1
63	GB/T5789-86	Flange Bolt M8×35	2
64	GF2.011105.01.15-05	Relay	1
65	GB/T5789-86	Flange Bolt M5×20	2
66	GF2.011105.01.01-6	Locating Pin 8×14	2
67	GF2.011105.01.01-02	Radial Ball Bearing 6207/C3	2
68	GF2.011105.01.01-7	Crankcase Packing	1
69	GF2.011105.01.15-06	Oil Level Switch Assembly	1
70	GF2.011105.01.01-03	Radial Ball Bearing 6202/P6	2
71	GF2.011105.01.04-1	Camshaft Complete	1
72	GF2.011105.01.00-11	Balance Gear	1
73	GF2.011105.01.00-12	Key	1
74	GF2.011105.01.03-1	Crankshaft Complete	1
75	GF2.011105.01.10-10	Governor Slider	1
76	GF2.011105.01.10-11	Governor Shaft Clip	1
77	GF2.011105.01.10-12	Governor Shaft	1
78	GF2.011105.01.10-13	Governor Weight Pin	3
79	GF2.011105.01.10-14	Governor Weight	3
80	GF2.011105.01.10-15	Governor Gear Wheel	1
81	GF2.011105.01.10-16	Washer	1
82	GF2.011105.01.03-01	Connecting Rod Assembly	1
83	GF2.011105.01.03-2	Piston Pin	1
84	GF2.011105.01.03-3	Piston Pin Clip	2
85	GF2.011105.01.03-4	Piston	1
	GF2.011105.01.03-02	Oil Seal Set Complete	1
86	GF2.011105.01.03-5	Second Ring Set	1
	GF2.011105.01.03-6	First Ring Set	1
87	GF2.011105.01.04-2	EX, Valve	1
88	GF2.011105.01.04-1	IN, Valve	1
89	GF2.011105.01.04-3	Valve Spring Washer	1
90	GF2.011105.01.04-4	Valve Oil Seal	1
91	GF2.011105.01.04-5	Valve Spring	2
92	GF2.011105.01.04-6	IN , Valve Spring Retainer	1
93	GF2.011105.01.04-7	Ex , Valve Spring Retainer	1
94	GF2.011105.01.04-8	Ex , Valve Cap	1
95	GF2.011105.01.01-8	Oil Drain Plug Washer	2
96	GF2.011105.01.01-9	Oil Drain Plug	2
97	GF2.011105.01.04-9	Valve Lifter	2
98	GF2.011105.01.04-10	Push Rod	2
99	GF2.011105.01.00-13	Bolt	4
100	GF2.011105.01.02-2	Stud	2
101	GF2.011105.01.02-03	Cylinder Head Complete	1
102	GF2.011105.01.00-14	Shroud	1
103	GF2.011105.01.02-3	Bolt	2
104	GF2.011105.01.02-4	Push Rod Guide Plate	1
105	GF2.011105.01.04-11	Pivot Bolt	2
106	GF2.011105.01.04-12	Valve Rocker Arm	2

Specifications

No	Item #	Description	Qty
107	GF2.011105.01.04-13	Pivot Adjusting Nut	2
108	GF2.011105.01.04-14	Locking Arm Nut	2
109	GF2.011105.01.15-01	Spark Plug	1
110	GF2.011105.01.06-3	Vacuum Pipe Packing1	1
111	GF2.011105.01.06-01	Vacuum Pipe Complete	1
112	GF2.011105.01.06-1	Rubber Tube	1
113	GF2.011105.01.06-2	Clip	2
114	GF2.011105.01.06-4	Gasket 2	1
115	GF2.011105.01.06-00	Mixer	1
116	GF2.011105.01.06-31	Valve Choke Handle	1
117	GF2.011105.50.00-3	Rubber Tube 1	1
118	GF2.011105.00.00-7	Clip	1
119	GF2.011105.01.06-5	Vacuum Pipe Packing3	1
120	GF2.011105.01.00-15	Cylinder Head Gasket	1
121	GF2.011105.01.00-16	Locating Pin	2
122	GF2.011105.01.15-07	Ignition Assembly	1
123	GB/T5789-86	Bolt M6×29	2
Generator			
1	GB/T5789	Bolt M5×12	2
2	GB/T93	Spring Washer 5	2
3	GB/T97.1	Washer 5	2
4	GF2.011209.02.00-1	Generator End Cover	1
5	GF2.011105.02.00-2	Wire Jacket	1
6	GF2.011209.02.00-01	Terminal	1
7	GB/T5789	Bolt M5×20	6
8	GF2.011209.02.00-02	Bridge	1
9	GF2.011209.02.00-03	AVR	1
10	GF2.011209.02.00-04	Brush Assembly	1
11	GB/T5789	Flange Bolt M6×180	4
12	GB/T93	Spring Washer 6	6
13	GB/T97.1	Washer 6	4
14	GF2.011209.02.00-2	End Cover	1
15	GF2.011105.02.01-00	Stator Assembly	1
16	GB/T5780	Flange Bolt M10×265	1
17	GB/T93	Spring Washer 5	1
18	GB/T96	Washer 10	1
19	GF2.011105.02.02-00	Rotor Complete	1
20	GB/T5789	Bolt M6×8	3
21	GF2.011105.02.00-01	Cover	1
22	GF2.011105.50.00-016	Fan Fixer 1	1
23	GF2.011105.50.00-018	Fan Fixer 3	1
24	GF2.011105.50.00-07	Fan	1
25	GB/T5789	Bolt M6×16	10
26	GF2.011105.50.00-017	Fan Fixer 2	1
27	GF2.011105.50.00-011	Front Cover Board	1
28	GB/T823	Bolt M6×12	12
29	GF2.011105.50.00-04	Back Cover Board	1
30	GF2.011105.50.00-00	Frame	1
31	GF2.011105.50.00-02	Middle Cover	1
32	GB/T823	Bolt M4×8	3
33	GB/T93	Spring Washer 4	3
34	GB/T97.1	Washer 4	14
35	GF2.011105.50.00-03	Engine Switch	1
36	GF2.011105.00.00-7	Clip	2
37	GF2.011105.50.00-3	Rubber Tube 1	1
38	GB/T5789	Bolt M6×12	9

Specifications

No	Item #	Description	Qty
39	GF2.011105.01.00-2	Muffler Protector 2	1
40	GF2.011105.01.00-1	Muffler Protector 1	1
41	GF2.011105.01.00-3	Muffler Protector 3	1
42	GF2.011105.01.00-00	Engine CC-188F-LPG	1
43	GF2.011105.50.00-4	Rubber Tube 2	1
44	GF2.011105.01.01-3	Crankcase Cover	1
45	GF2.011105.50.00-012	Demountable Transom	1
46	GB/T5789	Bolt M8×16	2
47	GT2.011105.50.00-46	Axle	1
	GT2.011105.50.00-45	"O" washer	2
48	GT2.011105.50.00-026	10" Solid Wheel	2
49	GB/T91	Pin	2
50	GB/T6177.2	Nut M10×1.25	4
51	GF2.011105.50.00-08	Bottom Rubber 2	2
52	GB/T6177.1	Nut M8	10
53	GF2.011105.50.00-05	Rubber Nog	8
54	GF2.011105.50.00-010	Storage Battery Tray	1
55	GF2.011105.04.00-03	Storage Battery	1
56	GB/T5789	Bolt M8×20	2
	GT2.011105.50.00-44	Support Leg	1
57	GF2.011105.50.00-09	Bottom Rubber 1	2
58	GB/T41	Nut M6	4
59	GT2.011105.50.00-027	Handle	2
	GT2.011105.50.00-025	Lock Pin	2
	GB/T5789	Bolt M8×45	2
60	GF2.011105.50.00-7	Wire Jacket 2	1
61	GF2.011105.04.04-1	Control Panel Cover	1
62	GF2.011105.04.02-04	Control Panel	1
63	GB/T845	Bolt ST4.2×16	8
64	GB/T823	Bolt M6×12	4
65	GF2.011105.50.00-5	Wire Jacket 1	1
66	GF2.011105.04.01-1	Ripple Tube1 (Ø25, 170)	1
67	GF2.011105.04.01-00	Wiring Harness	1
68	GF2.011105.04.02-1	Ripple Tube2 (Ø18, 300)	1
69	GF2.011105.04.02-00	Wiring Harness	1
70	GF2.011209.02.00-00	Electrical Machine	1
71	GB/T5785	Bolt M5×213	1
	GB/T93	Spring Washer 5	1
	GB/T41	Nut M5	1
Power Panel			
1	GF2.011105.04.00-08	DC Protector	1
2	GB/T41	Nut M3	6
	GB/T97.1	Washer 3	6
	GB/T93	Spring Washer 3	6
3	GF2.011209.04.00-08	Receptacle	1
4	GB/T6177.1	Nut M4	6
5	GF2.011209.04.00-07	Receptacle	1
6	GF2.011209.04.00-06	Receptacle	1
7	GF2.011105.04.00-013	Circuit Breaker	2
8	GF2.011105.04.00-012	Protector	1
9	GF2.011105.04.00-011	Electrical Starter	1
10	GF2.011105.04.02-3	Nut	1
11	GF2.011105.04.02-2F2	Gas Inlet	1
	GF2.011105.00.00-8F2	Gas inlet cover	1
12	GF2.011105.04.00-010	Voltmeter	1
13	GF2.011105.04.00-06	Ground Terminal	1

Specifications

No	Item #	Description	Qty
14	GB/T823	Bolt M3×6	4
	GB/T97.1	Washer 3	4
	GB/T93	Spring Washer 3	4
15	GB/T823	Bolt M4×16	6
	GB/T97.1	Washer 4	6
	GB/T93	Spring Washer 4	6
16	GB/T823	Bolt M3×10	2
	GB/T97.1	Washer 3	2
	GB/T93	Spring Washer 3	2
17	GF2.011105.04.00-015	Hour Meter	1
18	GF2.011209.04.00-05	DC-Receptacle	1

Troubleshooting

Troubleshooting

Problem	Cause	Solution
Generator will not start	Battery not connected	Connect the battery
	Battery not charged	Recharge or replace battery
	No fuel	Add fuel
	Faulty spark plug	Replace spark plug
	Unit loaded during start up	Remove load from unit
Generator will not start; Generator starts but runs roughly	Low oil level	Fill crankcase to the proper level Place generator on a flat, level surface
	Choke in the wrong position.	Adjust choke.
	Spark plug wire loose	Attach wire to spark plug
Generator shuts down during operation	Out of fuel	Fill fuel tank
	Low oil level	Fill crankcase to the proper level. Place generator on a flat, level surface
Generator cannot supply enough power or overheating	Generator is overloaded	Review load and adjust. See "Power Management"
	Insufficient ventilation	Check for air restriction. Move to a well ventilated area
No AC output	Cable not properly connected	Check all connections
	Connected device is defective	Replace defective device
	Circuit breaker is open	Reset circuit breaker
	Capacitor defective	Replace capacitor (Service Center)
	Faulty brush assembly	Replace brush assembly (Service Center)
	Faulty AVR	Replace AVR (Service Center)
	Loose wiring	Inspect and tighten wiring connections
Other	Contact the help line.	
Generator gallops	Engine governor defective	Contact the help line
Repeated circuit breaker tripping	Overload	Review load and adjust. See "Power Management"
	Faulty cords or device	Check for damaged, bare or frayed wires. Replace defective device

Warranty

CHAMPION POWER EQUIPMENT
1 YEAR LIMITED WARRANTY

Warranty Qualifications

Champion Power Equipment (CPE) will register this warranty upon receipt of your Warranty Registration Card and a copy of your sales receipt from one of CPE's retail locations as proof of purchase.

Please submit your warranty registration and your proof of purchase within ten (10) days of the date of purchase.

Repair/Replacement Warranty

CPE warrants to the original purchaser that the mechanical and electrical components will be free of defects in material and workmanship for a period of one (1) year from the original date of purchase (90 days for commercial & industrial use). This warranty only applies to the original purchaser and is not transferable.

Do not return the unit to the place of purchase

Contact CPE's Technical Service and CPE will troubleshoot any issue via phone or e-mail. If the problem is not corrected by this method, CPE will, at its option, authorize evaluation, repair or replacement of the defective part or component at a CPE Service Center. CPE will provide you with a case number for warranty service. Please keep it for future reference. Repairs or replacements without prior authorization, or at an unauthorized repair facility, will not be covered by this warranty.

Warranty Exclusions

This warranty will not apply to parts and/or labor if this generator is deemed to have been misused, neglected, involved in an accident, abused, loaded beyond the generator's limits, modified, installed improperly or connected incorrectly to any electrical component. Cosmetic defects such

as paint, decals, etc., are excluded from this warranty. *Warranty is Limited to 90-days from purchase for Commercial use, including Rentals.

Limits of Implied Warranty and Consequential Damage

Champion Power Equipment disclaims any obligation to cover any loss of time, use of this product, freight, or any incidental or consequential claim by anyone from using this generator. THIS WARRANTY IS IN LIEU OF ALL OTHER WARRANTIES, EXPRESS OR IMPLIED, INCLUDING WARRANTIES OF MERCHANTABILITY OR FITNESS FOR A PARTICULAR PURPOSE

A unit provided as an exchange will be subject to the warranty of the original unit. The length of the warranty governing the exchanged unit will remain calculated by reference to the purchase date of the original unit.

This warranty gives you certain legal rights which may change from state to state. Your state may also have other rights you may be entitled to that are not listed within this warranty.

Contact Information

Address

Champion Power Equipment, Inc.
Customer Service
10006 Santa Fe Springs Rd.
Santa Fe Springs, CA 90670

Customer Service

Mon – Fri 8:30 AM – 5:00 PM (PST/PDT)
Toll Free: 1-877-338-0999
Fax no.: 1-562-236-9429

Technical Service

Mon – Fri 8:30 AM – 5:00 PM (PST/PDT)
Toll Free: 1-877-338-0999
24 hr. Voicemail: 1-626-230-5248 or email:
tech@championpowerequipment.com

Warranty

**Champion Power Equipment, Inc (CPE),
and the United States Environment Protection Agency (U.S. EPA.)
Emission Control System Warranty**

Your Champion Power Equipment (CPE) engine complies with U.S. EPA emission regulations.

YOUR WARRANTY RIGHTS AND OBLIGATIONS:

The US EPA AND CPE are pleased to explain the Federal and California Emission Control Systems Warranty on your 2005 and later, small off-road engine. New engines must be designed, built and equipped, at the time of sale, to meet U.S. EPA regulations for small non-road engines. CPE must warrant the emission control system on your small off-road engine for the period of time listed below, provided there has been no abuse, neglect, unapproved modification, or improper maintenance of your small off-road engine.

Your emission control system may include parts such as the carburetor, fuel-injection system, the ignition system, catalytic converter and fuel lines. Also included may be hoses, belts, connectors and other emission related assemblies. Where a warrantable condition exists, CPE will repair your small off-road engine at no cost to you including diagnosis, parts and labor.

MANUFACTURER'S EMISSION CONTROL SYSTEM WARRANTY COVERAGE:

This emission control system is warranted for two years, subject to provisions set forth below. If, during the warranty period, emission related part on your engine is defective in materials or workmanship, the part will be repaired or replaced by CPE.

OWNER WARRANTY RESPONSIBILITIES:

As the small off-road engine owner, you are responsible for the performance of the required maintenance listed in your Owner's Manual. CPE recommends that you retain all your receipts covering maintenance on your small off-road engine, but CPE cannot deny warranty solely for the lack of receipts or for your failure to ensure the performance of all scheduled maintenance.

As the small off-road engine owner, you should however be aware that CPE may deny you warranty coverage if your small, off-road engine or a part has failed due to abuse, neglect, improper maintenance or unapproved modifications.

You are responsible for presenting your small off-road engine to an Authorized CPE service outlet, CPE dealer or CPE, Santa Fe Springs, Ca. as soon as a problem exists. The warranty repairs should be completed in a reasonable amount of time, not to exceed 30 days.

If you have any questions regarding your warranty rights and responsibilities, you should contact:

Champion Power Equipment, Inc.
Customer Service
10006 Santa Fe Springs Road
Santa Fe Springs, CA 90670
Tel: (888) 696-0668

The emission warranty is a defects warranty. Defects are judged on normal engine performance. The warranty is not related to an in-use emission test.

EMISSION CONTROL SYSTEM WARRANTY

The following are specific provisions relative to your Emission Control System Warranty Coverage.

Emission Control System Warranty (ECS Warranty) for 1997 and later model year engines):

1. APPLICABILITY: This warranty shall apply to 1997 and later model year engines). The ECS Warranty Period shall begin on the date the new engine or equipment is delivered to its original, end-use purchaser, and shall continue for 24 consecutive months thereafter.

2. GENERAL EMISSIONS WARRANTY COVERAGE

CPE warrants to the original, end-use purchaser of the new engine or equipment and to each subsequent purchaser that each of its small off-road engines is:

- a. Designed, built and equipped so as to conform at the time of sale with applicable regulations under section 213 of the Clean Air Act, as amended, 42 U.S.C. 7401 et seq.
- b. Free from defects in materials and workmanship that cause the failure of a warranted part to be identical in all material respects to the part as described in the engine manufacturer's application for certification for a period of two years.

3. THE WARRANTY ON EMISSION-RELATED PARTS WILL BE INTERPRETED AS FOLLOWS:

a. Any warranted part that is not scheduled for replacement as required maintenance in the Owners Manual shall be warranted for the ECS Warranty Period. If any such part fails during the ECS Warranty Period, it shall be repaired or replaced by CPE according to Subsection "d" below. Any such part repaired or replaced under the ECS Warranty shall be warranted for any remainder of the ECS Warranty Period.

b. Any warranted, emissions-related part which is scheduled only for regular inspection as specified in the Owners Manual shall be warranted for the ECS Warranty Period. A statement in such written instructions to the effect of "repair or replace as necessary", shall not reduce the ECS Warranty Period. Any such part repaired or replaced under the ECS Warranty shall be warranted for the remainder of the ECS Warranty Period.

c. Any warranted, emissions-related part which is scheduled for replacement as required maintenance in the Owner's Manual shall be warranted for the period of time prior to the first scheduled replacement point for that part. If the part fails prior to the first scheduled replacement, the part shall be repaired or replaced by CPE according to Subsection "d" below. Any such emissions-related part repaired or replaced under the ECS Warranty, shall be warranted for the remainder of the ECS Warranty Period prior to the first scheduled replacement point for such emissions-related part.

d. Repair or replacement of any warranted, emissions-related part under this ECS Warranty shall be performed at no charge to the owner at a CPE Authorized Service Outlet.

e. The owner shall not be charged for diagnostic labor which leads to the determination that a part covered by the ECS Warranty is in fact defective, provided that such diagnostic work is performed at a CPE Authorized Service Outlet.

f. CPE shall be liable for damages to other original engine components or approved modifications proximately caused by a failure under warranty of an emission-related part covered by the ECS Warranty.

g. Throughout the ECS Warranty Period, CPE shall maintain a supply of warranted emission-related parts sufficient to meet the expected demand for such emission-related parts.

h. Any CPE Authorized and approved emission-related replacement part may be used in the performance of any ECS Warranty maintenance or repair and will be provided without charge to the owner. Such use shall not reduce CPE's warranty obligation.

i. Unapproved add-on or modified parts may not be used to modify or repair a CPE engine. Such use voids this ECS Warranty and shall be sufficient grounds for disallowing an

Warranty

ECS Warranty claim. CPE shall not be liable hereunder for failures of any warranted parts of a CPE engine caused by the use of such an unapproved add-on or modified part.

EMISSION-RELATED PARTS INCLUDE THE FOLLOWING: (using those portions of the list applicable to the engine)

Systems covered by this warranty	Parts Description
Fuel Metering System	Fuel regulator, Carburetor and internal parts
Air Induction System	Air cleaner, Intake manifold
Ignition System	Spark plug and parts, Magneto ignition system
Exhaust System	Exhaust manifold, catalytic converter
Miscellaneous Parts	Tubing, Fittings, Seals, Gaskets, and Clamps associated with these listed systems.

TO OBTAIN WARRANTY SERVICE:

You must take your CPE engine or the product on which it is installed, along with your warranty registration card or other proof of original purchase date, at your expense, to any Champion Power Equipment dealer who is authorized by Champion Power Equipment, Inc. to sell and service that CPE product during his normal business hours. Claims for repair or adjustment found to be caused solely by defects in material or workmanship will not be denied because the engine was not properly maintained and used.

If you have any questions regarding your warranty rights and responsibilities, or to obtain warranty service, please write or call the Customer service of Champion Power Equipment, Inc.

**Champion Power Equipment, Inc.
10006 Santa Fe Springs Road
Santa Fe Springs, CA 90670
(888) 696-0668
Attn: Customer Service**

Notes