

Table of Contents

| | | | |
|-----------------------------------|-----------|--|-----------|
| Introduction | 1 | Specifications | 14 |
| 4" Water Pump | 1 | Engine Specifications..... | 14 |
| Accessories..... | 1 | Water pump Specifications..... | 14 |
| This Booklet..... | 1 | Fuel..... | 14 |
| Manual Conventions | 2 | Oil..... | 14 |
| Safety Rules | 3 | Spark Plugs | 14 |
| Controls and Features..... | 5 | Valve Clearance..... | 14 |
| Water Pump..... | 5 | Parts Diagram | 15 |
| Assembly | 7 | Parts List | 16 |
| Remove the Water Pump from the | | Troubleshooting | 17 |
| Shipping Carton..... | 7 | Warranty | 18 |
| Add Engine Oil | 7 | Warranty Qualifications | 18 |
| Add Fuel..... | 8 | Limited Repair/Replacement Warranty | 18 |
| Operation | 9 | Do not return the unit to the place of | |
| Water pump Location..... | 9 | purchase | 18 |
| Connecting a Hose Kit..... | 9 | Warranty Exclusions..... | 18 |
| Starting the Engine..... | 9 | Normal Wear | 18 |
| Stopping the Engine | 10 | Installation, Use and Maintenance..... | 18 |
| Maintenance | 11 | Other Exclusions | 18 |
| Engine Maintenance..... | 11 | Limits of Implied Warranty and | |
| Oil..... | 11 | Consequential Damage | 18 |
| Spark Plugs | 11 | Contact Information | 18 |
| Air Filter | 11 | Address..... | 18 |
| Cleaning | 12 | Customer Service | 18 |
| Adjustments | 12 | Technical Service..... | 18 |
| Maintenance Schedule..... | 12 | Notes | 22 |
| Storage | 13 | | |
| Engine Storage..... | 13 | | |
| Water pump Storage..... | 13 | | |

Introduction

Congratulations on your purchase of a Champion Power Equipment water pump. CPE designs and builds water pumps to strict specifications. With proper use and maintenance, this water pump will bring years of satisfying service.

4" Water Pump

This unit is a gasoline engine driven, impeller based water pump. It is designed to pump clear water only.

Accessories

Champion Power Equipment manufactures and sells accessories designed to help you get the most from your purchase. To find out more about our covers, hose kits and other accessories, please visit our web site at

www.championpowerequipment.com

This Booklet

Every effort has been made to ensure the accuracy and completeness of the information in this manual. We reserve the right to change, alter and/or improve the product and this document at any time without prior notice.

Record the model and serial numbers as well as date and place of purchase for future reference. Have this information available when ordering parts and when making technical or warranty inquiries.

| |
|---|
| Champion Power Equipment Support |
| 1-877-338-0999 |
| Model Number |
| C40940 |
| Serial Number |
| |
| Date of Purchase |
| |
| Purchase Location |
| |

Manual Conventions

Manual Conventions

This manual uses the following symbols to help differentiate between different kinds of information. The safety symbol is used with a key word to alert you to potential hazards in operating and owning power equipment.

Follow all safety messages to avoid or reduce the risk of serious injury or death.

DANGER

DANGER indicates an imminently hazardous situation which, if not avoided, *will* result in death or serious injury.

WARNING

WARNING indicates a potentially hazardous situation which, if not avoided, *could* result in death or serious injury.

CAUTION

CAUTION indicates a potentially hazardous situation which, if not avoided, *may* result in minor or moderate injury.

CAUTION

CAUTION used without the safety alert symbol indicates a potentially hazardous situation which, if not avoided, *may* result in property damage.

NOTE

If you have questions regarding your water pump, we can help. Please call our help line at 1-877-338-0999.

Safety Rules

WARNING

Read this manual thoroughly before operating your water pump. Failure to follow instructions could result in serious injury or death.

DANGER

DO NOT pump gasoline, oil-fuel mixtures, detergents, acids, chemicals, beverages, pesticides, fertilizers or any other flammable or corrosive liquids.

Pumping volatile liquids may result in an explosion or fire.
These liquids will corrode the pump and void your warranty.

WARNING

The engine exhaust from this product contains chemicals known to the state of California to cause cancer, birth defects, or other reproductive harm.

DANGER

Engine exhaust contains carbon monoxide, a colorless, odorless, poison gas. Breathing carbon monoxide will cause nausea, dizziness, fainting or death.

Operate water pump outdoors only in a well ventilated area
DO NOT operate the water pump inside any building, enclosure or compartment.
DO NOT allow exhaust fumes to enter a confined area through windows, doors, vents or other openings.

DANGER

Rotating parts can entangle hands, feet, hair, clothing and/or accessories.

Traumatic amputation or severe laceration can result.

Keep hands and feet away from rotating parts.
Tie up long hair and remove jewelry.
Operate equipment with guards in place.
DO NOT wear loose-fitting clothing, dangling drawstrings or items that could become caught.

DANGER

The water pump develops powerful force.

DO NOT move the water pump when it is in use.
DO NOT use hoses or connectors that are worn, damaged or frayed.
DO NOT allow children or unqualified persons to operate or service the water pump.

WARNING

DO NOT immerse this unit in water.

WARNING

Sparks can result in fire or electrical shock.

When servicing the water pump:
Disconnect the spark plug wire and place it where it cannot contact the plug.
DO NOT check for spark with the plug removed.
Use only approved spark plug testers.

Safety Rules

DANGER

Fuel and fuel vapors are highly flammable and extremely explosive.

Fire or explosion can cause severe burns or death.

Unintentional startup can result in entanglement, traumatic amputation or laceration.

When adding or removing fuel

Turn the engine off and let it cool for at least two minutes before removing the fuel cap. Loosen the cap slowly to relieve pressure in the tank. Only fill or drain fuel outdoors in a well-ventilated area.

DO NOT overfill the fuel tank.

Always keep fuel away from sparks, open flames, pilot lights, heat and other sources of ignition.

DO NOT light or smoke cigarettes.

When starting the water pump

DO NOT attempt to start a damaged water pump.

Make certain that the gas cap, air filter, spark plug, fuel lines and exhaust system are properly in place.

Allow spilled fuel to evaporate fully before attempting to start the engine.

Make certain that the water pump is resting firmly on level ground.

When operating the water pump:

DO NOT move or tip the water pump during operation.

DO NOT tip the water pump or allow fuel or oil to spill.

When transporting or servicing the water pump:

Make certain that the fuel shutoff valve is in the off position and the fuel tank is empty.

Disconnect the spark plug wire.

When storing the water pump:

Store away from sparks, open flames, pilot lights, heat and other sources of ignition.

WARNING

Water pumped through this unit shall not be used as drinking water.

WARNING

DO NOT pump salt, sludge, sewer, sea, or any other type of water containing solid material.

WARNING

Rapid retraction of the starter cord will pull hand and arm towards the engine faster than you can let go.

Unintentional startup can result in entanglement, traumatic amputation or laceration.

Broken bones, fractures, bruises or sprains could result.

When starting engine, pull the starter cord slowly until resistance is felt and then pull rapidly to avoid kickback.

CAUTION

Exceeding the water pump's specification for maximum head can damage the water pump and/or hose kits connected to it

DO NOT modify the water pump in any way.
DO NOT attempt to exceed the rated flow.
Attempting to increase the rated flow may damage the unit and/or shorten its life.

CAUTION

Improper treatment or use of the water pump can damage it, shorten its life and void your warranty.

Use the water pump only for intended uses.
Operate only on level surfaces.
DO NOT expose water pump to excessive moisture, dust, or dirt.
DO NOT allow any material to block the cooling slots.
DO NOT use the water pump if:
Equipment sparks, smokes or emits flames
Equipment vibrates excessively

Controls and Features

Read this owner's manual before operating your water pump. Familiarize yourself with the location and function of the controls and features. Save this manual for future reference.

Water Pump

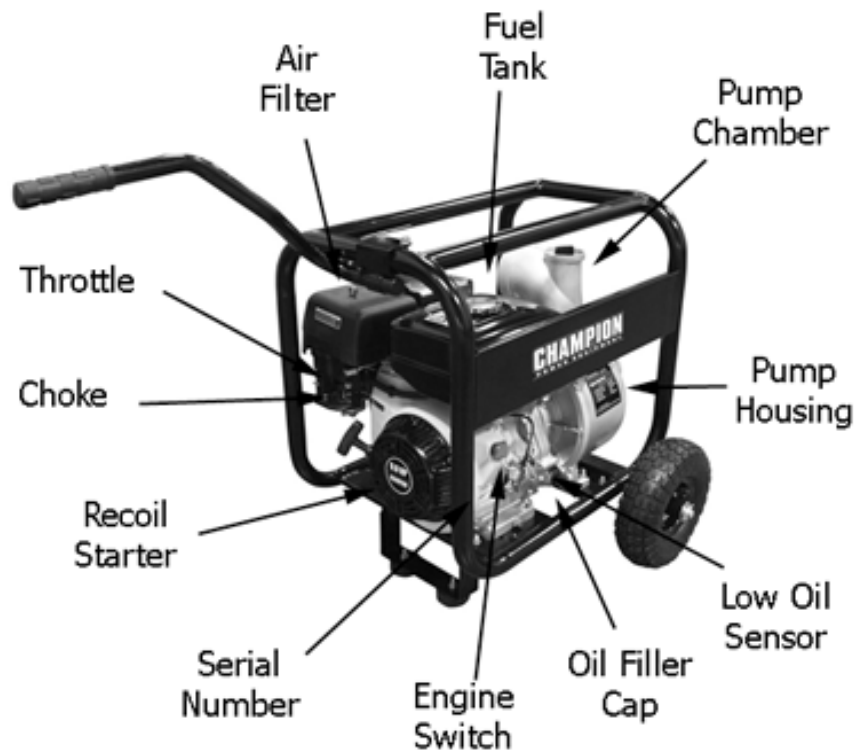

Fuel Tank – 1.56 gallon (5.9 L) capacity fuel tank

Muffler– Full-sized muffler

Air Filter – Protects the engine by filtering dust and debris from the intake air.

Throttle – Used to adjust engine speed

Choke – Used to start the engine

Recoil Starter – Used to start the engine

Engine Switch – Used to start the engine

Serial Number – Please have this number available when calling for assistance

Low Oil Sensor – Senses the level of oil in the crankcase and shuts the engine down if the level falls too low

Pump Housing – Impeller-based pump

Pump Chamber – fill with water prior to operation

4" Inlet – (not shown) 4" NPT inlet connector

4" Outlet – (not shown) 4" NPT outlet connector

Oil Filler Cap – (not shown) Check and fill engine oil level

Controls and Features

Parts Included

Your C49040 Gasoline Powered Water Pump ships with the following parts:

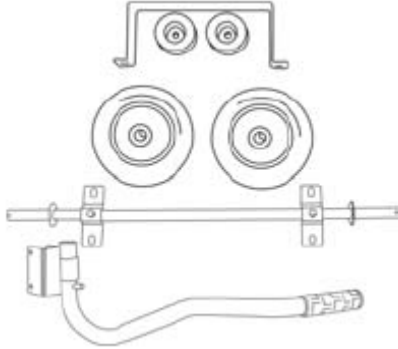

| | |
|------------------|----------|
| Wheel Kit | |
| Axle | 1 piece |
| 10" Solid Wheel | 2 pieces |
| Vibration Mounts | 2 pieces |
| Handle Assembly | 1 piece |



| | |
|----------------------|----------|
| Bolt Kit | |
| Wheel Retaining Pins | 2 pieces |
| Flat Washers | 2 pieces |
| "O" Washers | 2 pieces |
| Cap Screws and Nuts | 6 sets |

Assembly

Your water pump requires some assembly. This unit ships from our factory without oil. It must be properly serviced with fuel and oil before operation.

If you have any questions regarding the assembly of your water pump, call our help line at 1-877-338-0999. Please have your serial number and model number available.

Remove the Water Pump from the Shipping Carton

1. Set the shipping carton on a solid, flat surface.
2. Remove everything from the carton except the water pump.
3. Carefully cut each corner of the box from top to bottom. Fold each side flat on the ground to provide a surface area to install the mount kit and spark arrester.

Install the Wheel Kit

CAUTION

The wheel kit is not intended for over-the-road use.

You will need the following tools to install the wheels:

- 12 mm wrench
- Socket wrench with a 12 mm socket
- Pliers

1. Before adding oil to the engine, tip the generator slowly so that the engine side is up.
2. Slide the axle through both mounting brackets.
3. Slide a wheel onto the axel. Make certain that the valve stem is facing outward.
4. Place a washer on the end.
5. Install the cotter pin through the hole on the end of the axle.
6. Carefully bend the legs of the cotter pin back around the axle.
7. Repeat steps 3-6 to attach the second wheel.

Install the Support Leg

1. Attach the rubber vibration mount to the support leg with a cap screw (M8x20) and lock nut (M8).
2. Attach the support leg to the generator frame with cap screws (M8x30) and lock nuts (M8).
3. Tip the generator slowly so that it rests on the wheels and support leg.

Install the Handle

1. Line up the holes at the base of the handle with the receiving holes on the generator frame.
2. Thread cap screws (M8x50) through the frame and handle.
3. Place a lock nut (M8) on the end of the cap screw and fasten securely. **DO NOT** over tighten the lock nut.

Add Engine Oil

CAUTION

DO NOT attempt to crank or start the engine before it has been properly filled with the recommended type and amount of oil. Damage to the water pump as a result of failure to follow these instructions will void your warranty.

1. Place the water pump on a flat, level surface.
2. Remove oil fill cap/dipstick to add oil.
3. Add 1.16 qt (1.1 L) of oil and replace oil fill cap/dipstick.
4. Check engine oil level daily and add as needed.

CAUTION

The engine is equipped with a low-oil-shutoff and the will stop when the oil level in the crankcase falls below the threshold level.

Assembly



NOTE

Check oil often during the break-in period. Refer to the Maintenance section for recommended service intervals.

Add Fuel

1. Use clean, fresh, regular unleaded fuel with a minimum octane rating of 85.
2. DO NOT mix oil with fuel.
3. Clean the area around the fuel cap.
4. Remove the fuel cap
5. Slowly add fuel to the tank. DO NOT overfill. Allow approximately ½ inch of space for fuel expansion.
6. Screw on the fuel cap and wipe away any spilled fuel.



CAUTION

Use regular unleaded gasoline with a minimum octane rating of 85.

Do not mix oil and gasoline.

Fill tank to approximately ½" below the top of the tank to allow for fuel expansion.

DO NOT fill fuel tank indoors.

DO NOT fill fuel tank when the engine is running or hot.

DO NOT overfill the fuel tank.

DO NOT light cigarettes or smoke when filling the fuel tank.

Operation

Water pump Location

Place the water pump in a well-ventilated area. DO NOT place the water pump near vents or intakes where exhaust fumes could be drawn into occupied or confined spaces. Carefully consider wind and air currents when positioning water pump. This water pump must have at least five feet of clearance from combustible material. Leave at least three feet of clearance on all sides of the water pump to allow for adequate cooling, maintenance and servicing. Place the pump on a level surface free from any obstructions or potential hazards. The pump should be placed close to the water level to ensure maximum pump performance.

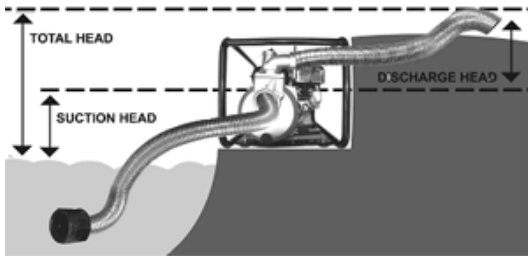

Pump output will be affected by the type, length, and size of the suction and discharge hoses. The pumping height, also known as the total head, is the distance from the water level to the point of discharge. As this distance increases, pump output decreases. The discharge capacity is greater than the suction capacity. Therefore, it is important that the suction head is less than the discharge head. The time required to draw water from the source to the pump (self-priming time) can be decreased by minimizing the suction head.

Connecting a Hose Kit

Connect an intake filter to one side of the suction hose. Connect a suction hose to the intake port of your pump (lower port).

NOTE

Both the intake and discharge ports are 4 in. NPT. Please insure the connectors to the suction and discharge hose are 4 in. NPT threaded.



Attach the discharge hose to the discharge port (upper port). Remove the cap from the pump chamber and completely fill the chamber with clean water. Tighten the cap.

WARNING

DO NOT run the pump dry.

Running the pump dry can destroy the pump seal and will void the warranty. If the pump was running while dry, stop the engine and allow it to cool thoroughly before filling the chamber with water.



Starting the Engine

1. Make certain the water pump is on a flat, level surface.
2. Turn the fuel valve to the "On" position.
3. Move the choke lever left to the "Choke" position.

Operation

4. Move the throttle to the left approximately $\frac{1}{2}$ towards the maximum position.
5. Pull the starter cord slowly until resistance is felt and then pull rapidly
6. As engine warms up, move the choke lever to "Run".



NOTE

If the engine starts but does not run, make certain that the water pump is on a flat, level surface. The engine is equipped with a low oil sensor that will prevent the engine from running when the oil level falls below a critical threshold.

Pump performance can be adjusted using the throttle. To decrease pump output, slide the throttle to the right. To increase it, slide the throttle to the left.

Stopping the Engine

1. Turn the ignition switch to the "Off" position.
2. Turn the fuel valve to the "Off" position.
3. Allow the engine to cool thoroughly.
4. Remove the cap from the cooling pump chamber and allow it drain completely.

Maintenance

The owner/operator is responsible for all periodic maintenance.

WARNING

Never operate a damaged or defective water pump.

WARNING

Improper maintenance will void your warranty.

Complete all scheduled maintenance in a timely manner. Correct any issue before operating the water pump.

NOTE

For service or parts assistance, contact our help line at 1-877-338-0999.

Engine Maintenance

To prevent accidental starting, remove and ground spark plug wire before performing any service.

Oil

Change oil when the engine is warm. Refer to the oil specification to select the proper grade of oil for your operating environment.

1. Remove the oil drain plug with a 12 mm socket and extension.
2. Allow the oil to drain completely.
3. Replace the drain plug.
4. Remove oil fill cap/dipstick to add oil.
5. Add 1.16 qt (1.1 L) of oil and replace oil fill cap/dipstick.
6. Dispose of used oil at an approved waste management facility.

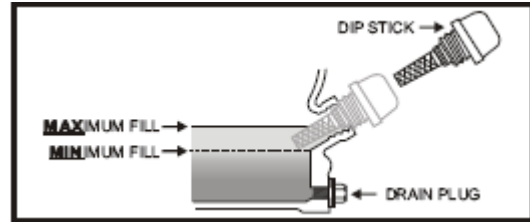

Spark Plugs

1. Remove the spark plug cable from the spark plug.
2. Use a 14 mm long reach spark plug socket to remove the plug.
3. Inspect the electrode on the plug. It must be clean and not worn to produce the spark required for ignition.
4. Make certain the spark plug gap is 0.7 - 0.8mm (0.028 - 0.031 in.).
5. Refer to the spark plug recommendation chart when replacing the plug.
6. Carefully thread the plug into the engine.
7. Use the spark plug tool to firmly install the plug.
8. Attach the spark plug wire to the plug.

Air Filter

1. Remove the snap-on cover holding the air filter to the assembly.
2. Remove the foam element.
3. Wash in liquid detergent and water. Squeeze thoroughly dry in a clean cloth.
4. Saturate in clean engine oil.
5. Squeeze in a clean, absorbent cloth to remove all excess oil.
6. Place the filter in the assembly.
7. Reattach the air filter cover and snap in place.

Maintenance

Cleaning



CAUTION

DO NOT spray engine with water.

Water can contaminate the fuel system.

Use a damp cloth to clean exterior surfaces of the engine.

Use a soft bristle brush to remove dirt and oil.

Use an air compressor (25 PSI) to clear dirt and debris from the engine.

Adjustments

CPE recommends that you contact our service line at 1-877-338-0999 for all other service and/or adjustment needs.

Maintenance Schedule

Follow the service intervals indicated in the schedule below.

Service your water pump more frequently when operating in adverse conditions.

Contact our help line at 1-877-338-0999 to locate the nearest Champion Power Equipment certified service dealer for your water pump or engine maintenance needs.

| |
|---|
| Every 8 hours or daily |
| Check oil level |
| Clean around air intake and muffler |
| First 5 Hours |
| Change oil |
| First 10 hours |
| Check/Adjust Valve Clearance * |
| Every 50 hours or every season |
| Clean air filter |
| Change oil if operating under heavy load or in hot environments |
| Every 100 hours or every season |
| Change oil |
| Clean/Adjust spark plug |
| Check/Adjust valve clearance * |
| Clean fuel tank and filter * |
| Every 3 years |
| Replace fuel line |

* To be performed by knowledgeable, experienced owners or Champion Power Equipment certified service dealers

Storage

For longer term storage, please follow these guidelines.

Engine Storage

1. Allow the engine to cool completely before storage.
2. Clean the engine according to the instructions in the Maintenance section.
3. Drain all fuel completely from the fuel line and carburetor to prevent gum from forming.
4. Add a fuel stabilizer into the fuel tank.
5. Change the oil.

6. Remove the spark plug and pour about $\frac{1}{2}$ ounce of oil into the cylinder. Crank the engine slowly to distribute the oil and lubricate the cylinder.
7. Reattach the spark plug.

Water pump Storage

1. Allow the water pump to cool completely before storage.
2. Turn off the fuel supply at the fuel valve.
3. Drain the pump chamber thoroughly.
4. Clean the water pump according to the instructions in the Maintenance section.
5. Store the unit in a clean, dry area.
6. Store in a clean, dry place out of direct sunlight.

Specifications

Specifications

Engine Specifications

Engine 9.0 HP OHV CPE
EPA & CARB certified

Water pump Specifications

Inlet Diameter 4 inch NPT
Outlet Diameter 4 inch NPT
Fuel Capacity 1.56 gallons (5.9 L)
Total Head 92 feet (28 m)
Suction Head 26 feet (8 m)
Max Delivery Volume 475 Gal/min
(1800 L/min)

Weight 123.2 lbs. (55.8 kg)
Height 23.1 inches (58.7 cm)
Width 18.3 inches (46.5 cm)
Length 29.84 inches (75.8 cm)

Fuel

Fuel capacity is 1.56 US gallons (5.9 L). Use regular unleaded gasoline with a minimum octane rating of 85.

Oil

Oil capacity is 1.16 qt (1.1 L).

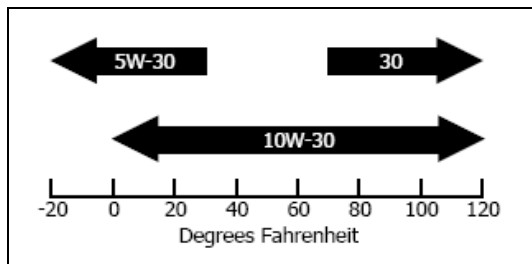

Spark Plugs

Your water pump comes equipped with a 3/4" long reach plug (14mm).

Intermittent use (less than 1 hour/month) or colder temperatures (below 60°F)
NGK B6ES or equivalent

Moderate use (less than 3 hours/month) or seasonal temperatures (50-80°F)
NGK B7ES or equivalent

Extreme use (continuous) or hot climates (80-100°F)
NGK B8ES or equivalent

Make certain the spark plug gap is 0.7 - 0.8mm (0.028 - 0.031 in.).

Valve Clearance

Intake 0.13-0.17mm (0.005 – 0.007 in.)
Exhaust 0.18-0.22mm (0.007 – 0.009 in.)

Parts Diagram

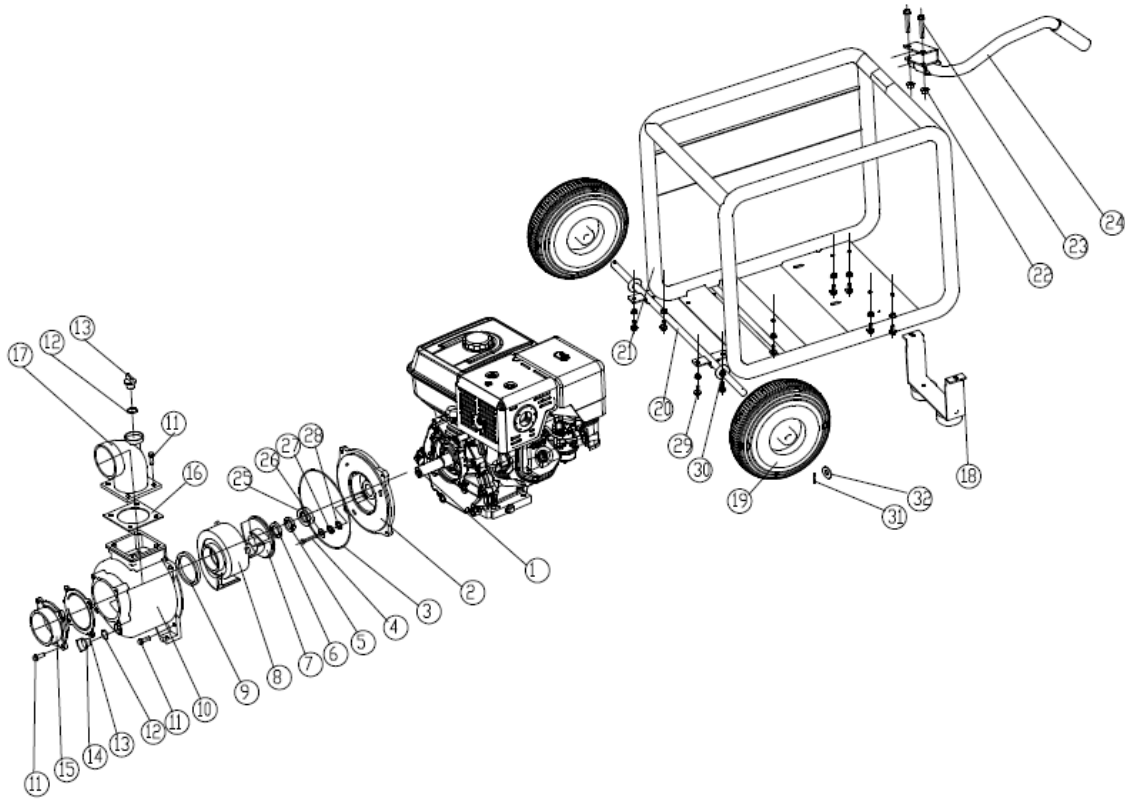

Specifications

Parts List

| No | Item # | Description | Quantity |
|----|-------------------|--------------------------|----------|
| 1 | ST177F-100000T | 9.0HP WP Engine | 1 |
| 2 | WP-40-1000500 | Pump Base Plate | 1 |
| 3 | WP-40-1000502 | Pump body "O" Seal | 1 |
| 4 | GB70-HS8-55 | Hex Screw M8×55 | 4 |
| 5 | WP-40-1000402 | Impeller Wear Ring | 1 |
| 6 | WP-40-1000403 | Impeller Seal | 1 |
| 7 | WP-40-1000401 | Impeller | 1 |
| 8 | WP-40-1000302 | Spiral Case | 1 |
| 9 | WP-40-1000301 | Spiral Case "O" seal | 1 |
| 10 | WP-40-1000200 | Pump Housing | 1 |
| 11 | GB5789-FB-10-32 | Flange Bolt M10×32 | 12 |
| 12 | WP-40-1000208 | Plug "O" Ring | 2 |
| 13 | WP-40-1000209 | One-Way Valve | 1 |
| 14 | WP-40-1000207 | Threaded Plug | 2 |
| 15 | WP-40-1000206N | Discharge Manifold (NPT) | 1 |
| 16 | WP-40-1000203N | 90° Intake Elbow (NPT) | 1 |
| 17 | WP-40-1000204 | Seal Packing | 1 |
| 18 | ST168FD-1150400 | Support Leg | 1 |
| 19 | ST188FD-1740100-D | Wheel | 2 |
| 20 | GB6170-86- M8 | Nut M8 | 16 |
| 21 | GB5789-FB8-16 | Flange Bolt M8×16 | 6 |
| 22 | ST168FD-1150301 | Axle | 1 |
| 23 | WP-40-2000100E | Frame | 1 |
| 24 | GB6170-86-M8 | Nut M8 | 16 |
| 25 | GB5789-FB8-40 | Flange Bolt M8×40 | 2 |
| 26 | ST168FD1150200 | Handle | 1 |
| 27 | WP-40-1000510 | Casing Wear Ring | 1 |
| 28 | WP-40-1000219 | Washer | 4 |
| 29 | WP-40-1000220 | Washer | 4 |
| 30 | WP-40-1000221 | Washer | 4 |
| 31 | GBT91-CP3.2-40 | Cotter Pin 3.2×40 | 2 |
| 32 | GB97.1-85-C49040 | Flat Washer | 2 |

Troubleshooting

| Problem | Cause | Solution |
|--|------------------------------|--|
| Water pump will not start | No fuel | Add fuel |
| | Faulty spark plug | Replace spark plug |
| Water pump will not start; Water pump starts but runs roughly | Low oil level | Fill crankcase to the proper level Place water pump on a flat, level surface |
| | Choke in the wrong position. | Adjust choke. |
| | Spark plug wire loose | Attach wire to spark plug |
| Water pump shuts down during operation | Out of fuel | Fill fuel tank |
| | Low oil level | Fill crankcase to the proper level. Place water pump on a flat, level surface |
| Water pump overheating or performing poorly | Strainer or hose clogged | Remove debris from strainer or hose |
| | Pump not primed | Re-prime pump |
| | Suction hose out of water | Place suction hose under the surface of the water |
| | Head limit exceeded | Relocate pump so suction head is less than discharge head (maximum 98 feet) |
| | Air leak | Tighten connectors and clamps or replace seal packing |

Warranty

Warranty

CHAMPION POWER EQUIPMENT 1 YEAR LIMITED WARRANTY

Effective September 1, 2006. Replaces all undated warranties and all warranties dated before September 1, 2006.

Warranty Qualifications

Champion Power Equipment (CPE) will register this warranty upon receipt of your Warranty Registration Card and a copy of your sales receipt from one of CPE's retail locations as proof of purchase.

Please submit your warranty registration and your proof of purchase within ten (10) days of the date of purchase.

Limited Repair/Replacement Warranty

CPE warrants to the original purchaser that the mechanical and electrical components will be free of defects in material and workmanship for a period of one (1) year from the original date of purchase (90 days for commercial & industrial use). Transportation charges on product submitted for repair or replacement under this warranty are the sole responsibility of the purchaser. This warranty applies only to the original purchaser and is not transferable.

Do not return the unit to the place of purchase

Contact CPE's Technical Service and CPE will troubleshoot any issue via phone or e-mail. If the problem is not corrected by this method, CPE will, at its option, authorize evaluation, repair or replacement of the defective part or component at a CPE Service Center. CPE will provide you with a case number for warranty service. Please keep it for future reference. Repairs or replacements without prior authorization, or at an unauthorized repair facility, will not be covered by this warranty.

Warranty Exclusions

This warranty does not cover the following repairs and equipment:

Normal Wear

Water pumps need periodic parts and service to perform well. This warranty does not cover repair when normal use has exhausted the life of a part or the equipment as a whole.

Installation, Use and Maintenance

This warranty will not apply to parts and/or labor if this water pump is deemed to have been misused, neglected,

involved in an accident, abused, modified, installed improperly or connected incorrectly to any hose kit. Pumping chemicals, solvents, pesticides or any material other than clear water voids this warranty. Normal maintenance such as spark plugs, air filters, adjustments, fuel system cleaning and obstruction due to buildup is not covered by this warranty.

Other Exclusions

This warranty excludes:

Cosmetic defects such as paint, decals, etc.

Wear items such as filter elements, o-rings, etc.

Accessory parts such as starting batteries, storage covers and hose kits

Failures due to acts of God and other force majeure events beyond the manufacturer's control

Limits of Implied Warranty and Consequential Damage

Champion Power Equipment disclaims any obligation to cover any loss of time, use of this product, freight, or any incidental or consequential claim by anyone from using this water pump. THIS WARRANTY IS IN LIEU OF ALL OTHER WARRANTIES, EXPRESS OR IMPLIED, INCLUDING WARRANTIES OF MERCHANTABILITY OR FITNESS FOR A PARTICULAR PURPOSE

A unit provided as an exchange will be subject to the warranty of the original unit. The length of the warranty governing the exchanged unit will remain calculated by reference to the purchase date of the original unit.

This warranty gives you certain legal rights which may change from state to state. Your state may also have other rights you may be entitled to that are not listed within this warranty.

Contact Information

Address

Champion Power Equipment, Inc.
Customer Service
10006 Santa Fe Springs Rd.
Santa Fe Springs, CA 90670

Customer Service

Mon – Fri 8:30 AM – 5:00 PM (PST/PDT)
Toll Free: 1-877-338-0999
Fax no.: 1-562-236-9429

Technical Service

Mon – Fri 8:30 AM – 5:00 PM (PST/PDT)
Toll Free: 1-877-338-0999
24 hr. Voicemail: 1-626-230-5248 or email:
tech@championpowerequipment.com

**Champion Power Equipment, Inc (CPE),
The California Air Resources Board (CARB) and the United States Environment Protection
Agency (U.S. EPA.)
Emission Control System Warranty**

Your Champion Power Equipment (CPE) engine complies with both the U.S. EPA and state of California Air Resources Board (CARB) emission regulations.

YOUR WARRANTY RIGHTS AND OBLIGATIONS:

The California Air Resources Board, US EPA AND CPE are pleased to explain the Federal and California Emission Control Systems Warranty on your 2005 and later, small off-road engine. In California, new, small off-road engines must be designed, built and equipped to meet the State's stringent anti smog standards. In the other states, new engines must be designed, built and equipped, at the time of sale, to meet U.S. EPA regulations for small non-road engines. CPE must warrant the emission control system on your small off-road engine for the period of time listed below, provided there has been no abuse, neglect, unapproved modification, or improper maintenance of your small off-road engine.

Your emission control system may include parts such as the carburetor, fuel-injection system, the ignition system, catalytic converter and fuel lines. Also included may be hoses, belts, connectors and other emission related assemblies. Where a warrantable condition exists, CPE will repair your small off-road engine at no cost to you including diagnosis, parts and labor.

MANUFACTURER'S EMISSION CONTROL SYSTEM WARRANTY COVERAGE:

This emission control system is warranted for two years, subject to provisions set forth below. If, during the warranty period, emission related part on your engine is defective in materials or workmanship, the part will be repaired or replaced by CPE.

OWNER WARRANTY RESPONSIBILITIES:

As the small off-road engine owner, you are responsible for the performance of the required maintenance listed in your Owner's Manual. CPE recommends that you retain all your receipts covering maintenance on your small off-road engine, but CPE cannot deny warranty solely for the lack of receipts or for your failure to ensure the performance of all scheduled maintenance.

As the small off-road engine owner, you should however be aware that CPE may deny you warranty coverage if your small, off-road engine or a part has failed due to abuse, neglect, improper maintenance or unapproved modifications.

You are responsible for presenting your small off-road engine to an Authorized CPE service outlet, CPE dealer or CPE, Santa Fe Springs, Ca. as soon as a problem exists. The warranty repairs should be completed in a reasonable amount of time, not to exceed 30 days.

If you have any questions regarding your warranty rights and responsibilities, you should contact:

Champion Power Equipment, Inc.
Customer Service
10006 Santa Fe Springs Road
Santa Fe Springs, CA 90670
Tel: (888) 696-0668

The emission warranty is a defects warranty. Defects are judged on normal engine performance. The warranty is not related to an in-use emission test.

Warranty

EMISSION CONTROL SYSTEM WARRANTY

The following are specific provisions relative to your Emission Control System Warranty Coverage.

Emission Control System Warranty (ECS Warranty) for 1995 and later model year California small off-road engines (for other states, 1997 and later model year engines):

1. APPLICABILITY: This warranty shall apply to 1995 and later model year California small off-road engines (for other states, 1997 and later model year engines). The ECS Warranty Period shall begin on the date the new engine or equipment is delivered to its original, end-use purchaser, and shall continue for 24 consecutive months thereafter.

2. GENERAL EMISSIONS WARRANTY COVERAGE

CPE warrants to the original, end-use purchaser of the new engine or equipment and to each subsequent purchaser that each of its small off-road engines is:

a. Designed, built and equipped so as to conform with all applicable regulations adopted by the Air Resources Board pursuant to its authority in Chapters 1 and 2, Part 5, Division 26 of the Health and Safety Code, and

b. Free from defects in materials and workmanship that cause the failure of a warranted part to be identical in all material respects to the part as described in the engine manufacturer's application for certification for a period of two years.

3. THE WARRANTY ON EMISSION-RELATED PARTS WILL BE INTERPRETED AS FOLLOWS:

a. Any warranted part that is not scheduled for replacement as required maintenance in the Owners Manual shall be warranted for the ECS Warranty Period. If any such part fails during the ECS Warranty Period, it shall be repaired or replaced by CPE according to Subsection "d" below. Any such part repaired or replaced under the ECS Warranty shall be warranted for any remainder of the ECS Warranty Period.

b. Any warranted, emissions-related part which is scheduled only for regular inspection as specified in the Owners Manual shall be warranted for the ECS Warranty Period. A statement in such written instructions to the effect of "repair or replace as necessary", shall not reduce the ECS Warranty Period. Any such part repaired or replaced under the ECS Warranty shall be warranted for the remainder of the ECS Warranty Period.

c. Any warranted, emissions-related part which is scheduled for replacement as required maintenance in the Owner's Manual shall be warranted for the period of time prior to the first scheduled replacement point for that part. If the part fails prior to the first scheduled replacement, the part shall be repaired or replaced by CPE according to Subsection "d" below. Any such emissions-related part repaired or replaced under the ECS Warranty, shall be warranted for the remainder of the ECS Warranty Period prior to the first scheduled replacement point for such emissions-related part.

d. Repair or replacement of any warranted, emissions-related part under this ECS Warranty shall be performed at no charge to the owner at a CPE Authorized Service Outlet.

e. The owner shall not be charged for diagnostic labor which leads to the determination that a part covered by the ECS Warranty is in fact defective, provided that such diagnostic work is performed at a CPE Authorized Service Outlet.

f. CPE shall be liable for damages to other original engine components or approved modifications proximately caused by a failure under warranty of an emission-related part covered by the ECS Warranty.

g. Throughout the ECS Warranty Period, CPE shall maintain a supply of warranted emission-related parts sufficient to meet the expected demand for such emission-related parts.

h. Any CPE Authorized and approved emission-related replacement part may be used in the performance of any ECS Warranty maintenance or repair and will be provided without charge to the owner. Such use shall not reduce CPE's warranty obligation.

Warranty

i. Unapproved add-on or modified parts may not be used to modify or repair a CPE engine. Such use voids this ECS Warranty and shall be sufficient grounds for disallowing an ECS Warranty claim. CPE shall not be liable hereunder for failures of any warranted parts of a CPE engine caused by the use of such an unapproved add-on or modified part.

EMISSION-RELATED PARTS INCLUDE THE FOLLOWING: (using those portions of the list applicable to the engine)

| Systems covered by this warranty | Parts Description |
|---|--|
| Fuel Metering System | Fuel regulator, Carburetor and internal parts |
| Air Induction System | Air cleaner, Intake manifold |
| Ignition System | Spark plug and parts, Magneto ignition system |
| Exhaust System | Exhaust manifold, catalytic converter |
| Miscellaneous Parts | Tubing, Fittings, Seals, Gaskets, and Clamps associated with these listed systems. |
| Evaporative Emissions | Fuel Tank, Fuel Cap, Fuel Line, Fuel Line Fittings, Clamps, Pressure Relief Valves, Control Valves, Control Solenoids, Electronic Controls, Vacuum Control Diaphragms, Control Cables, Control Linkages, Purge Valves, Vapor Hoses, Liquid/Vapor Separator, Carbon Canister, Canister Mounting Brackets, Carburetor Purge Port Connector |

TO OBTAIN WARRANTY SERVICE:

You must take your CPE engine or the product on which it is installed, along with your warranty registration card or other proof of original purchase date, at your expense, to any Champion Power Equipment dealer who is authorized by Champion Power Equipment, Inc. to sell and service that CPE product during his normal business hours. Claims for repair or adjustment found to be caused solely by defects in material or workmanship will not be denied because the engine was not properly maintained and used.

If you have any questions regarding your warranty rights and responsibilities, or to obtain warranty service, please write or call the Customer service of Champion Power Equipment, Inc.

**Champion Power Equipment, Inc.
10006 Santa Fe Springs Road
Santa Fe Springs, CA 90670
(888) 696-0668
Attn: Customer Service**

Notes

Notes