

CHAMPION

POWER EQUIPMENT™

OWNER'S MANUAL



35 Ton LOG SPLITTER



MODEL NUMBER

93520

SAVE THESE INSTRUCTIONS
Important Safety Instructions
are included in this manual.

MADE IN CHINA
REV 93520-20161201

12039 Smith Ave.
Santa Fe Springs CA 90670
USA / 1-877-338-0999
www.championpowerequipment.com

AN IMPORTANT MESSAGE ABOUT TEMPERATURE:

Your Champion Power Equipment product is designed and rated for continuous operation at ambient temperatures up to 40°C (104°F). When your product is needed your product may be operated at temperatures ranging from -15°C (5°F) to 50°C (122°F) for short periods. If the product is exposed to temperatures outside this range during storage, it should be brought back within this range before operation. In any event, the product must always be operated outdoors, in a well-ventilated area and away from doors, windows and other vents.

Have questions or need assistance?

Do not return this product to the store!

WE ARE HERE TO HELP!

Visit our website:

www.championpowerequipment.com

for more info:

- Product Info & Updates
- Tech Bulletins
- Frequently Asked Questions
- Product Registration

– or –

Call our Customer Care Team Toll-Free at:

1-877-338-0999

Parts Ordering:

Mon – Fri 8:30 AM – 5:00 PM (PST/PDT)

Toll Free: 1-877-338-0999

For residents of California:

WARNING: This product contains chemicals known to the State of California to cause cancer or birth defects and other reproductive harm.

WARNING: The engine exhaust from this product contains chemicals known to the State of California to cause cancer and birth defects and other reproductive harm.

*We are always working to improve our products. Therefore, the enclosed product may differ slightly from the image on the cover.

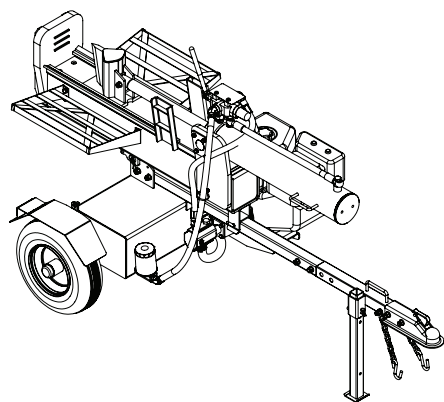

35 Ton LOG SPLITTER

TABLE OF CONTENTS

| | | | |
|--|-----------|--|-----------|
| Introduction | 1 | Maintenance and Storage | 18 |
| Manual Conventions | 2 | Engine Maintenance | 18 |
| Safety Rules | 3 | Oil | 18 |
| Training | 5 | Spark Plugs | 18 |
| Preparation | 5 | Air Filter | 18 |
| Operation | 6 | Log Splitter Maintenance | 18 |
| Maintenance and Storage | 6 | Changing the Hydraulic Oil | |
| Controls and Features | 7 | and Oil Filter | 19 |
| Log Splitter | 7 | Cleaning | 20 |
| Assembly | 8 | Maintenance Schedule | 20 |
| Open Shipping Crate | 8 | Storage | 20 |
| 1) Install the Hydraulic Oil Filter | 8 | Log Splitter Storage | 20 |
| 2) Install the Fenders | 8 | Engine stored for Less than 30 Days | 20 |
| 3) Install the Wheels | 8 | Engines Stored for Over 30 Days | 20 |
| 4) Install the Tow Bar | 8 | Troubleshooting | 21 |
| 5) Install the Beam | 9 | Specifications | 22 |
| 6) Install the Cylinder and Wedge | 9 | Log Splitter Specifications | 22 |
| 7) Install the Engine and Hoses | 10 | Engine Specifications | 22 |
| High Pressure Hose | 11 | Spark Plugs | 22 |
| Suction Hose | 11 | Maintenance Valve Clearance | 22 |
| Oil Return Hose | 11 | Hydraulic Oil System | 22 |
| 8) Install the Log Catcher | 11 | Fuel | 22 |
| Add Hydraulic Oil | 11 | Oil | 22 |
| Add Engine Oil | 12 | An Important Message About Temperature | 22 |
| Add Fuel | 13 | Parts Diagram | 23 |
| Operation | 14 | Parts List | 24 |
| Before Each Use Inspect the Log Splitter | 14 | Engine Parts Diagram | 25 |
| Towing Log Splitter Safety | 14 | Engine Parts List | 26 |
| Log Splitter Location | 14 | | |
| Starting the Engine | 15 | | |
| Stopping the Engine | 15 | | |
| Log Splitter Operation | 16 | | |
| Operation at High Altitude | 17 | | |

INTRODUCTION

Congratulations on your purchase of a Champion Power Equipment product. Champion Power Equipment and Champion Engine Technology designs, builds, and supports all of our products to strict specifications and guidelines. With proper product knowledge, safe use, and regular maintenance, this product should bring years of satisfying service.

Every effort has been made to ensure the accuracy and completeness of the information in this manual, and we reserve the right to change, alter and/or improve the product and this document at any time without prior notice.

Since CPE/CET highly value how our products are designed, manufactured, operated and are serviced, and also highly value your safety and the safety of others, we would like you to take the time to review this product manual and other product materials thoroughly and be fully aware and knowledgeable of the assembly, operation, dangers and maintenance of the product before use. Fully familiarize yourself, and make sure others who plan on operating the product fully familiarize themselves too, with the proper safety and operation procedures before each use. Please always exercise common sense and always err on the side of caution when operating the product to ensure no accidents, property damage, or injury occurs. We want you to continue to use and be satisfied with your CPE/CET product for years to come.

Record the model and serial numbers as well as date and place of purchase for future reference. Have this information available when ordering parts and when making technical or warranty inquiries.

| |
|--|
| 1-877-338-0999 |
| Model Number |
| 93520 |
| Serial Number |
| |
| Date of Purchase |
| |
| Purchase Location |
| |
| For Oil Type see 'Add Engine Oil' section. For Fuel Type see 'Add Fuel' section. |

This manual uses the following symbols to help differentiate between different kinds of information. The safety symbol is used with a key word to alert you to potential hazards in operating and owning power equipment.

Follow all safety messages to avoid or reduce the risk of serious injury or death.

 **DANGER**

DANGER indicates an imminently hazardous situation which, if not avoided, **will** result in death or serious injury.

 **WARNING**

WARNING indicates a potentially hazardous situation which, if not avoided, **could** result in death or serious injury.

 **CAUTION**

CAUTION indicates a potentially hazardous situation which, if not avoided, **may** result in minor or moderate injury.

CAUTION

CAUTION used without the safety alert symbol indicates a potentially hazardous situation which, if not avoided, **may** result in property damage.

 **NOTE**

If you have questions regarding your log splitter, we can help. Please call our help line at **1-877-338-0999**

SAFETY RULES

WARNING

Read this manual thoroughly before operating your log splitter. Failure to follow instructions could result in serious injury or death.

WARNING

The engine exhaust from this product contains chemicals known to the state of California to cause cancer, birth defects, or other reproductive harm.

DANGER

Log Splitter engine exhaust contains carbon monoxide, a colorless, odorless, poison gas. Breathing carbon monoxide will cause nausea, dizziness, fainting or death. If you start to feel dizzy or weak, get to fresh air immediately.

Operate log splitter outdoors only in a well ventilated area. DO NOT operate the log splitter inside any building, enclosure or compartment. DO NOT allow exhaust fumes to enter a confined area through windows, doors, vents or other openings. **DANGER CARBON MONOXIDE**, using a log splitter indoors **CAN KILL YOU IN MINUTES**.

DANGER

Rotating parts can entangle hands, feet, hair, clothing and/or accessories. Traumatic amputation or severe laceration can result.

Keep hands and feet away from rotating parts. Tie up long hair and remove jewelry. Operate equipment with guards in place. DO NOT wear loose-fitting clothing, dangling drawstrings or items that could become caught.

WARNING

Operation of this equipment may create sparks that can start fires around dry vegetation.

A spark arrestor may be required. The operator should contact local fire agencies for laws or regulations relating to fire prevention requirements.

DANGER

Sparks can result in fire or electrical shock.

When servicing the engine:

Disconnect the spark plug wire and place it where it cannot contact the plug. DO NOT check for spark with the plug removed. Use only approved spark plug testers.

WARNING

Running engines produce heat. Severe burns can occur on contact. Combustible material can catch fire on contact.

DO NOT touch hot surfaces. Avoid contact with hot exhaust gases. Allow equipment to cool before touching. Maintain at least 3 ft. (91.4 cm) of clearance on all sides to ensure adequate cooling. Maintain at least 5 ft. (1.5 m) of clearance from combustible materials.

WARNING

Crush Hazard

Wedge can cut through skin and break bones. Keep all limbs away from wedge and endplate.

WARNING

Projectile Hazard

Pieces of log may be ejected from the splitter while operating. **Wear ANSI approved safety glasses when operating. Be alert.**

WARNING

Keep Operator Work Zone Clear

Keep work zone clear of debris while working to ensure safe footing.

WARNING

Before removing the pin installed into the front support leg make sure hitch is installed onto vehicle. Releasing the pin before will cause support leg to slide up and possibly cause injury.

⚠ DANGER

Skin Injection Hazard. High pressure hydraulic oil can inject under your skin.

Make sure all fittings are tightly secure before applying pressure. Relieve system of pressure before servicing.

⚠ WARNING**Towing Hazard**

ALWAYS check all local and state regulations regarding towing, licensing and lights before towing your log splitter. Review towing safety warnings in your towing vehicle manual.

Drive safely. Be aware of the added length of the log splitter. NEVER ride or transport cargo on the log splitter. Choose a level surface to operate the log splitter.

NEVER EXCEED MAX. Towing Speed 45 MPH (72 KPH)

⚠ WARNING

Rapid retraction of the starter cord will pull hand and arm towards the engine faster than you can let go. Unintentional startup can result in entanglement, traumatic amputation or laceration. Broken bones, fractures, bruises or sprains could result.

When starting engine, pull the starter cord slowly until resistance is felt and then pull rapidly to avoid kickback.

⚠ CAUTION

Parts of the hydraulic circuit (cylinder, pump, valve-body, hoses) can become very hot during operation.

⚠ DANGER

Fuel and fuel vapors are highly flammable and extremely explosive.

Fire or explosion can cause severe burns or death. Unintentional startup can result in entanglement, traumatic amputation or laceration.

When adding or removing fuel:

Turn the engine off and let it cool for at least two minutes before removing the fuel cap. Loosen the cap slowly to relieve pressure in the tank. Only fill or drain fuel outdoors in a well-ventilated area. DO NOT pump gas directly into the engine at the gas station. Use an approved container to transfer the fuel to the engine.

DO NOT overfill the fuel tank.

Always keep fuel away from sparks, open flames, pilot lights, heat and other sources of ignition. DO NOT light or smoke cigarettes.

When starting the engine:

DO NOT attempt to start a damaged engine. Make certain that the gas cap, air filter, spark plug, fuel lines and exhaust system are properly in place. Allow spilled fuel to evaporate fully before attempting to start the engine.

Make certain that the log splitter is resting firmly on level ground.

When operating the log splitter:

DO NOT move or tip the log splitter during operation.

DO NOT tip the log splitter or allow fuel or oil to spill from the engine. Block the wheels to prevent unintended movement.

When transporting or servicing the log splitter:

Make certain that the fuel shutoff valve is in the off position and the fuel tank is empty.

Disconnect the spark plug wire.

When storing the log splitter:

Store away from sparks, open flames, pilot lights, heat and other sources of ignition.

⚠ CAUTION

Improper treatment or use of the log splitter can damage it, shorten its life and void your warranty.

Use the log splitter only for intended uses. Operate only on level surfaces. DO NOT expose log splitter to excessive moisture, dust, or dirt.

DO NOT allow any material to block the cooling slots. DO NOT use the engine if:

- Equipment sparks, smokes or emits flames
- Equipment vibrates excessively

SAFETY RULES

Training

1. Read the Operator's Manual completely before attempting to use this log splitter.
2. Do not allow anyone to operate your log splitter who has not read the Operator's Manual or has not been instructed on the safe use of the log splitter.
3. Never allow children or untrained adults to operate this machine.
4. Many accidents occur when more than one (1) person operates the log splitter. If a helper is assisting in loading logs to be split, never actuate controls until helper is clear of the area.
5. Never allow anyone to ride on the machine.
6. Never transport cargo on the log splitter.
7. High fluid pressures are developed in hydraulic log splitters. Pressurized hydraulic fluid escaping through a pin hole opening can puncture skin and cause sever blood poisoning. Therefore, the following instructions should be heeded at all times.
 - a. Do not operate the unit with frayed, kinked, cracked or damaged hoses, fittings, or tubing.
 - b. Stop the engine and relieve hydraulic system pressure before changing or adjusting fittings, hoses, tubing, or other system components.
 - c. Do not adjust the pressure settings of the pump or valve.
 - d. Do not check for leaks with your hand. Leaks can be detected by passing cardboard or wood over the suspected area. Look for discoloration. If injured by escaping fluid, see a doctor at once. Serious infection or reaction can develop if proper medical treatment is not administered immediately.
8. Keep the operator zone and adjacent area clear for safe, secure footing.
9. If your log splitter is equipped with an internal-combustion engine and intended for use near any unimproved forest, brush, or grass covered land, the engine exhaust should be equipped with a spark arrestor. Make sure you comply with local, state, and federal codes. Take appropriate fire-fighting equipment with you.
10. Log splitters should be used only for splitting wood. Do not use for other purposes unless the manufacturer provides attachments and instructions.

Preparation

1. Be thoroughly familiar with all controls and with proper use of the equipment.
2. Safety Gear:
 - a. Always wear safety shoes or heavy boots when operating the machine.
 - b. Always wear safety glasses or goggles when operating the machine.
 - c. Never wear jewelry or loose-fitting clothing that might become entangled in moving or rotating parts of the machine.
3. Make sure the splitter is on a level surface. Block tires and ensure support leg is secure to prevent unintended movement of the log splitter during operation.
 - a. Always operate the splitter from the manufacturer's indicated operator zone.
4. Logs to be split on ram-type units should be cut as squarely as possible.
5. Fuel:
 - a. Use an approved fuel container.
 - b. Never add fuel to a running or hot engine.
 - c. Fill fuel tank outdoors with extreme care. Never fill fuel tank indoors.
 - d. Replace gasoline cap securely and clean up any spilled fuel.

Operation

1. Before starting this log splitter, review all safety rules. Failure to follow these rules may result in serious injury to the operator or bystanders.
2. Be sure to confirm all hose connections and hose clamps are tight before each use. It is possible for connections to vibrate loose over time.
3. Never leave the machine unattended with the power source operating.
4. Never operate the machine when under the influence of alcohol, drugs or medication.
5. The machine owner should instruct all operators in safe log splitter operation.
6. Always operate the log splitter with all safety equipment in place and all controls properly adjusted for safe operation.
7. Always operate the log splitter at manufacturer's recommended speed.
8. Always keep hands and feet clear of moving parts.
9. When loading a ram-type log splitter, place your hands on the sides of the log, not the ends. Never place your hands or any part of your body between a log and any part of the log splitter.
10. On ram-type log splitters, never attempt to split more than one (1) log at a time unless the ram has been fully extended and a second log is needed to complete the separation of the first log.
11. On ram-type log splitters on which the logs are not cut square, the longest portion of the log should be rotated down and the most square end placed against the ram.
12. Use only your hand to operate the log splitter controls.
13. Do not refuel the engine until it has cooled for several minutes.

Maintenance and Storage

1. Always shut off the power source while repairing or adjusting the splitter except as recommended by the manufacturer.
2. Clean debris and chaff from the engine cylinder, cylinder head fins, recoil starter cover, and muffler areas. If the engine is equipped with a spark arrestor muffler, clean and inspect it regularly (follow manufacturer's service instructions). Replace, if damaged.
3. Never store the unit indoors with fuel in the tank. Fumes might reach an open flame spark. Allow the engine to cool before storing in any enclosure.
4. Clear debris from moveable parts, but only when the power source is shut off.
5. Check to be sure all nuts and bolts are tight to assure the equipment is in safe working condition.

CONTROLS AND FEATURES

Read this owner's manual before operating your log splitter. Familiarize yourself with the location and function of the controls and features. Save this manual for future reference.

Log Splitter

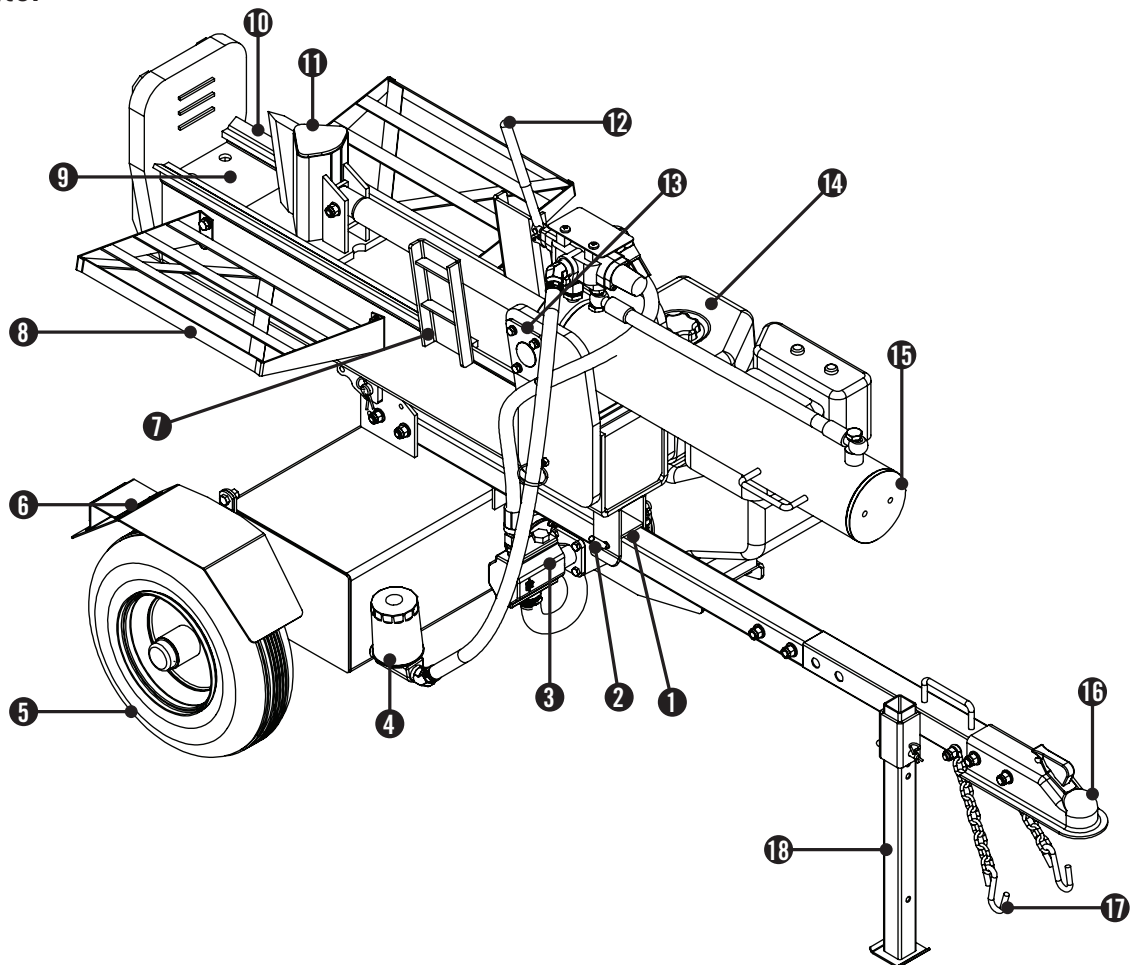

- | | |
|--|---|
| <p>(1) Beam Bracket – Holds splitting beam in place.</p> <p>(2) Beam Lock Pin – Secures in either horizontal or vertical position.</p> <p>(3) Hydraulic Pump – Pumps hydraulic oil through the system.</p> <p>(4) Hydraulic Oil Filter</p> <p>(5) Wheels – Maximum travel speed is 45 MPH (72 KPH).</p> <p>(6) Fenders</p> <p>(7) Log Strippers</p> <p>(8) Log Catchers – Prevents split logs from falling to the ground.</p> <p>(9) Splitting Beam</p> | <p>(10) Log Cradle – Prevents log from rolling off the beam.</p> <p>(11) Wedge</p> <p>(12) Control Valve Handle – Controls the movement of the cutting wedge.</p> <p>(13) Mounting Plates – Holds hydraulic cylinder in place.</p> <p>(14) Engine – 338 cc, OHV, 4-stroke, air cooled.</p> <p>(15) Hydraulic Cylinder – 5 in. bore (12.7 cm) x 23 in. (58.4 cm) stroke. Rated to 3600 psi.</p> <p>(16) 2 in. (5.1 cm) Ball Coupler – For towing the log splitter behind your vehicle.</p> <p>(17) Safety Chains – For use while towing.</p> <p>(18) Support Leg – Supports log splitter while operating. Raise leg for towing.</p> |
|--|---|

Your log splitter requires some assembly.

If you have any questions regarding the assembly of your log splitter, call our help line at 1-877-338-0999. Please have your serial number and model number available.

Open Shipping Crate

1. Set the shipping crate on a solid, flat surface
2. Carefully cut the shipping bands and remove lid of shipping crate.
3. Locate all hardware before beginning assembly.

1) Install the Hydraulic Oil Filter

Install the oil filter base onto the hydraulic oil tank.

The barb fitting should be oriented vertically and once installed the oil filter should be oriented so that it does not extend below the hydraulic oil tank.

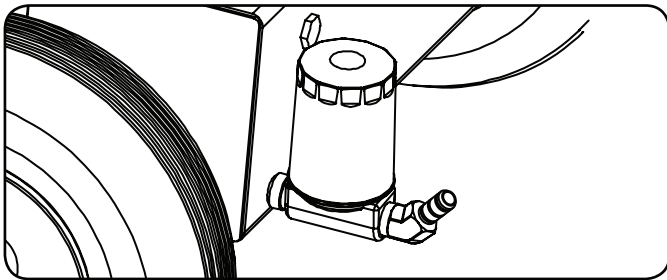

2) Install the Fenders

1. Attach the fender to the side of the hydraulic oil tank with an M10x30 bolt, M10 washer, M10 lock washer and M10 nut. The safety reflector should be facing the back of the hydraulic oil tank.
2. Repeat with second fender on opposite side.

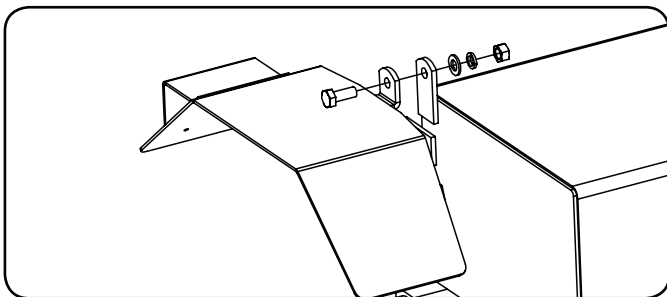

3) Install the Wheels

1. Place bearings in the wheel hub and orient the bearing so that the taper on the bearing matches the taper on the hub.
2. Press the bearing seal flush into the hub. Use a hammer and wood block to flush the seal with the end of the hub.
3. Slide the wheel over the axle on the hydraulic oil tank.
4. Install the castle nut and tighten by hand. Tighten another ¼ turn with a wrench to seat the bearing.

3) Install the Wheels Cont'd.

5. Spin the wheel to distribute grease.
6. Loosen the castle nut and re-tighten by hand.
7. Install the cotter pin through the castle nut and axle and spread the ends of the pin to prevent the nut from backing off.
8. Place axle cap over castle nut and axle. Use a hammer and wood block to seat the cap.
9. Repeat steps 1-8 for the other wheel.

NOTE

Keep the wheel hub clean and free from debris during assembly.

CAUTION

Over-tightening the castle nut will cause the bearings to run hot and fail prematurely.

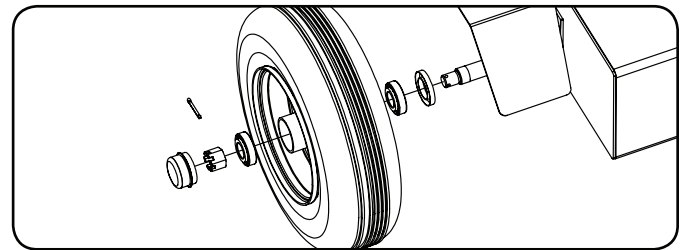

4) Install the Tow Bar

1. Assemble two piece tow bar with two M12x65 bolts and M12 lock nuts and washers. (A)

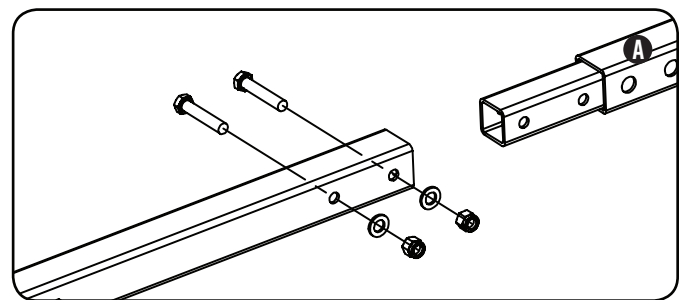

2. Attach the tow bar to the bracket on top of the hydraulic oil tank with two M12x85 bolts and M12 lock nuts. (B) Tighten to 50 ft-lb.

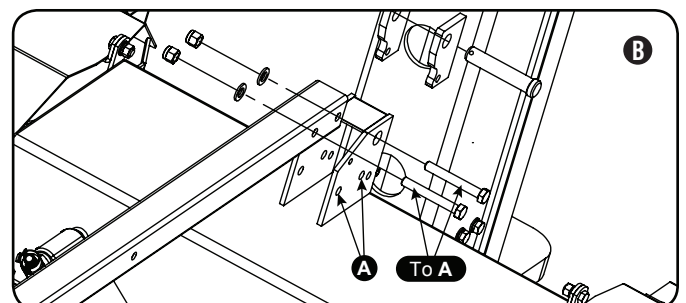

ASSEMBLY

4) Install the Tow Bar Cont'd.

3. Install the front support leg and secure with pin and R-pin (hairpin clip). (C)

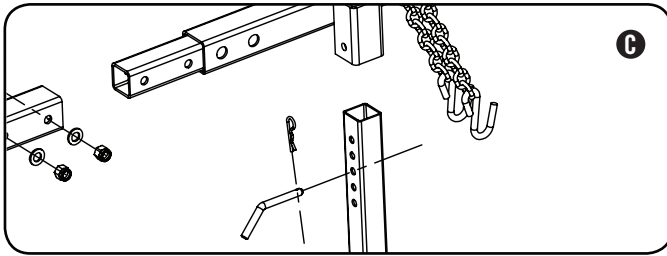

5) Install the Beam

1. Stand the beam upright on foot plate behind the hydraulic oil tank. (A)

⚠ WARNING

The beam is very heavy and should only be moved or lifted by at least 2 able persons at all times during assembly process. Use extreme caution to avoid injury.

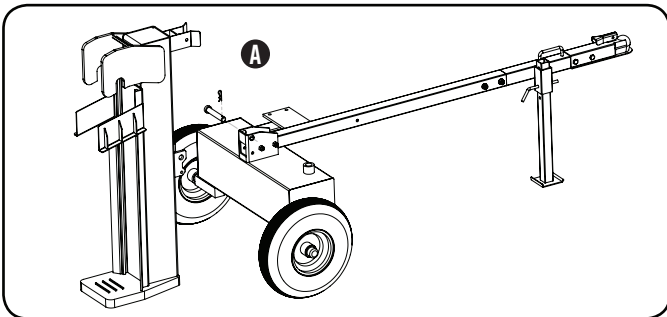

2. Slowly lift the front of the tow bar to roll the frame toward the beam and carefully align the pivot holes on the bottom of the beam and the top of the hydraulic oil tank.
3. Once aligned, secure the beam to the tank with hitch pin and R-pin. (B)
4. Hold the top of the beam by the cylinder mount and carefully rotate the beam toward the tow bar.

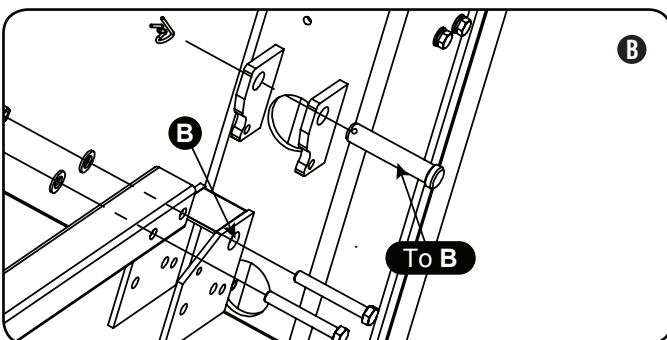

5) Install the Beam Cont'd.

5. Once the bracket on the bottom of the beam is aligned with the tow bar, secure the beam in the horizontal position with pin and R-pin. (C)

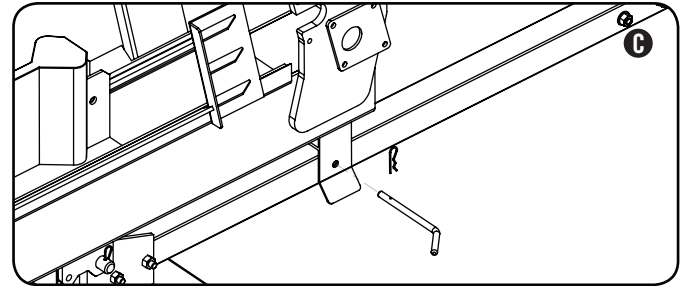

6) Install the Cylinder and Wedge

1. Place the wedge on the beam between the cylinder mounts and slide it forward into the rails. (A)
2. Remove the cylinder mounting plates. (A)

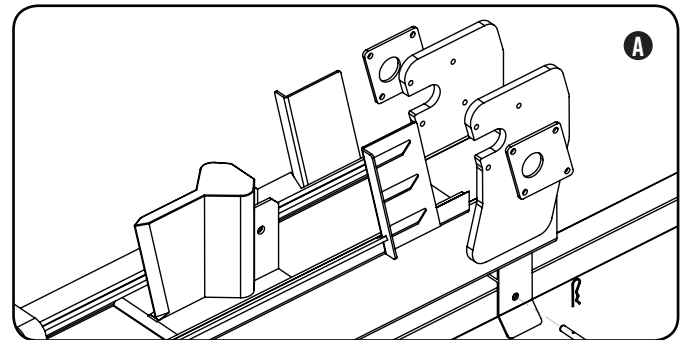

3. Install the cylinder by sliding the pegs at the end of the cylinder into the mounting slots on top of the beam. Be sure to slide the cylinder all the way back into the mounting slots. (B)

NOTE

The cylinder will support itself when slid all the way back into the mounting slots.

4. Secure the cylinder mounting plates with hardware removed in step 2. (B)
5. Slide the wedge back toward the cylinder and align the bolt hole in the wedge with the bolt hole in the cylinder rod. (B)

NOTE

The cylinder rod may need to be rotated slightly in order to properly align the the wedge. Insert a screwdriver into the bolt hole in the cylinder rod and slowly rotate as needed.

6) Install the Cylinder and Wedge Cont'd.

- Secure the wedge to the cylinder rod with an M12x75 bolt and M12 nut. Lightly tighten the nut to approximately 5 ft-lb. (B)

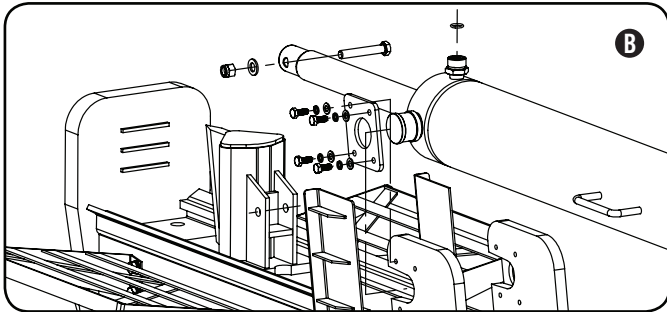

7) Install the Engine and Hoses

- Attach the engine/pump to the engine mounting plate on the hydraulic oil tank. (A) Secure with hardware provided.
- Place O-ring into the outlet fitting on the top of the pump. (A)

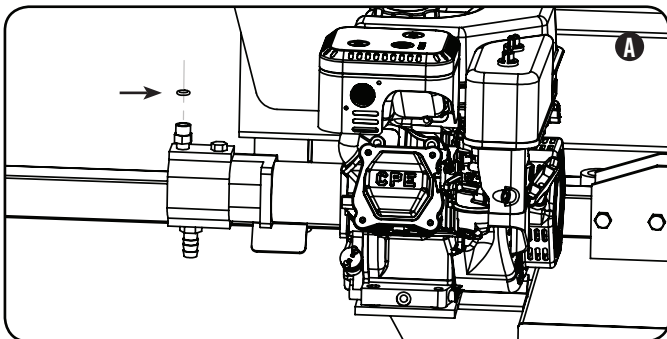

- Connect one end of the high pressure hose to the pump outlet fitting and the other end to the inlet on the control valve. (B)

NOTE

The swivel nut end of the high pressure hose connects to the pump outlet.

NOTE

The pump outlet connection does NOT require teflon tape. The o-ring seals against the face of the fittings on the pump and hose. Tighten to approximately 12 ft-lb. Over-tightening can damage the pump.

7) Install the Engine and Hoses Cont'd.

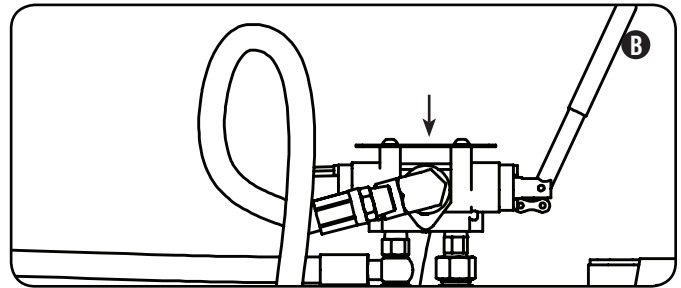

- Connect one end of the clear oil hose to the hydraulic oil tank just beneath the engine and the other end to the pump inlet on the bottom of the pump. (C)

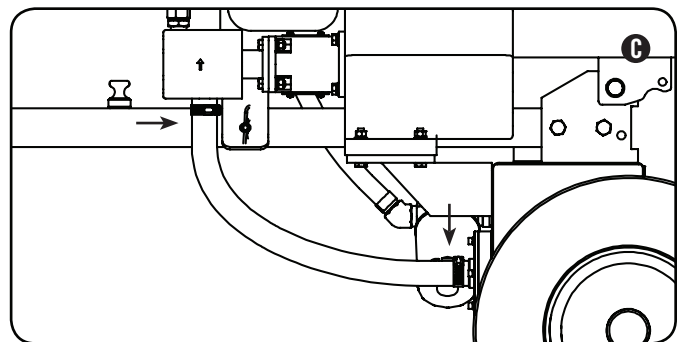

- Connect one end of the oil return hose to the outlet barb fitting on the control valve and the other end to the barb fitting on the oil filter. (D)
- Install the hose retaining ring to the side of the splitting beam. (E)

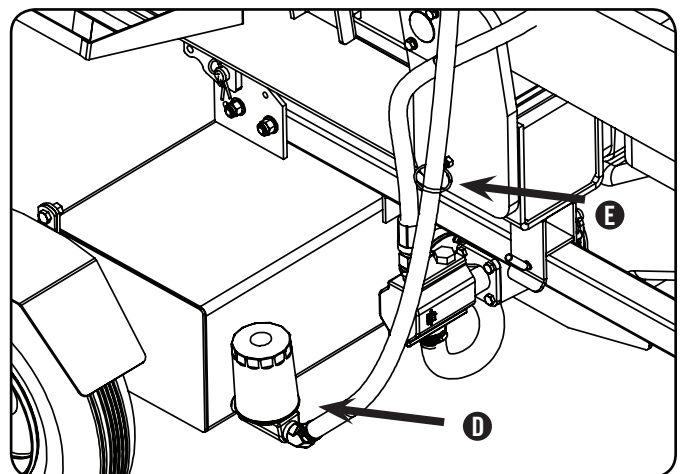

ASSEMBLY

7) Install the Engine and Hoses Cont'd.

High Pressure Hose

- This is the only hose with steel connectors crimped on both ends.
- One end connects to the Control Valve (sealed with teflon tape).
- Other end connects to the top of the Pump (sealed by O-Ring).
- Because of the male/female ends, this hose only fits the correct way.

Suction Hose

- This is the clear hose that connects the hydraulic tank to the pump inlet.
- Both ends of the hose are secured with hose clamps

Oil Return Hose

- This hose returns the oil exiting the cylinder to the tank.
- It has no connectors crimped onto it.
- The hose ends push over barbed fittings on the control valve and the oil filter.
- Both ends are secured with hose clamps.
- Notice how the hose is placed through the retainer ring on the beam. This holds the hose close to the frame so it does not flop out beyond the wheels (and catch on things while towing).

8) Install the Log Catcher

1. Attach log catcher to side of beam with four M10x15 bolts, M10 lock washers, and M10 washers.
2. Repeat step 1 for the other side.

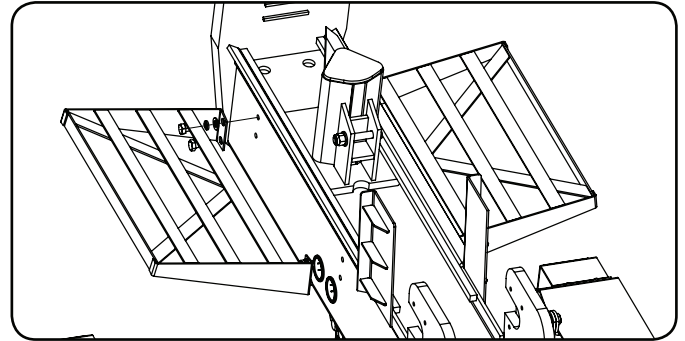

Add Hydraulic Oil

1. Make sure the log splitter is on a flat, level surface.
2. Remove the oil plug from the oil tank. (A)
3. Add 7 gal. (26.5 L) of hydraulic oil - 10W AW32, ASLE H-150, or ISO 32 are all acceptable types of fluid.
4. Check the hydraulic oil level using the oil sight glass. Oil level should visibly fill the glass sight. (B)
5. Replace and tighten the oil plug and orient the vent hole away from the operator zone.

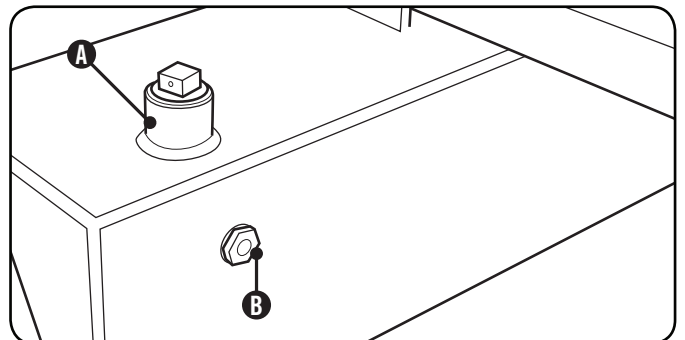

6. Start Engine. Extend and retract the wedge to purge air from the hydraulic system. When the wedge motion is smooth, the system is properly purged.
7. Stop the engine and check the hydraulic oil tank sight glass. Add approximately 1 to 2 gal. (3.8 to 7.6 L) of hydraulic oil to bring the level back up to the sight glass.
8. Check oil level daily and add as needed.

Add Hydraulic Oil Cont'd.

NOTE

When temperature is below 32° F (0°C) use universal tractor/transmission fluid.

WARNING

DO NOT remove the hydraulic oil fill cap when the engine is running or hot. Hot oil can escape causing severe burns. Always allow the log splitter to cool completely before removing the hydraulic oil cap. High fluid pressure and temperatures are created in the hydraulic log splitters. Hydraulic fluid will escape through a pin-size hole opening and can puncture skin and cause severe blood poisoning. Inspect hydraulic system regularly for possible leaks. Never check for leaks with your hand while the system is pressurized. Seek medical attention immediately if injured by escaping fluid.

Add Engine Oil

CAUTION

DO NOT attempt to crank or start the engine before it has been properly filled with the recommended type and amount of oil. Damage to the log splitter as a result of failure to follow these instructions will void your warranty.

1. Make sure the log splitter is on a flat, level surface.
2. Remove oil fill cap/dipstick to add oil.
3. Add up to 1.2 qt. (1.1 L) of oil (SAE 10W-30) - oil should cover all but 2 threads of filler hole. Replace oil fill cap/dipstick. DO NOT OVERFILL.
4. Check engine oil level daily and add as needed.

CAUTION

The engine is equipped with a low oil shut-off and will stop when the oil level in the crankcase falls below the threshold level.

NOTE

Check oil often during the break-in period. Refer to the Maintenance section for recommended service intervals.

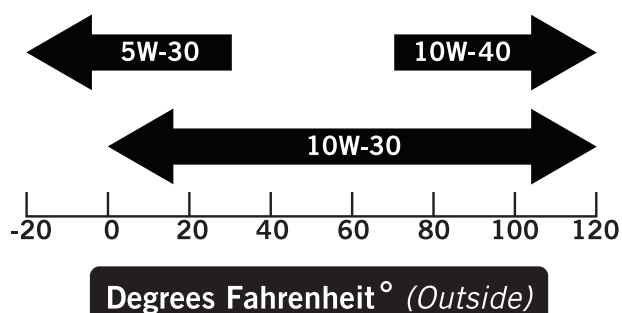

ASSEMBLY

Add Fuel

1. Use clean, fresh, regular unleaded fuel with a minimum octane rating of 85 and an ethanol content of less than 10% by volume.
2. DO NOT mix oil with fuel.
3. Clean the area around the fuel cap.
4. Remove the fuel cap.
5. Slowly add fuel to the tank. DO NOT OVERFILL. Fuel can expand after filling. A minimum of $\frac{1}{4}$ in. (6.4 mm) of space left in the tank is required for fuel expansion, more than $\frac{1}{4}$ in. (6.4 mm) is recommended. Fuel can be forced out of the tank as a result of expansion if it is overfilled, and can affect the stable running condition of the product. When filling the tank, it is recommended to leave enough space for the fuel to expand.

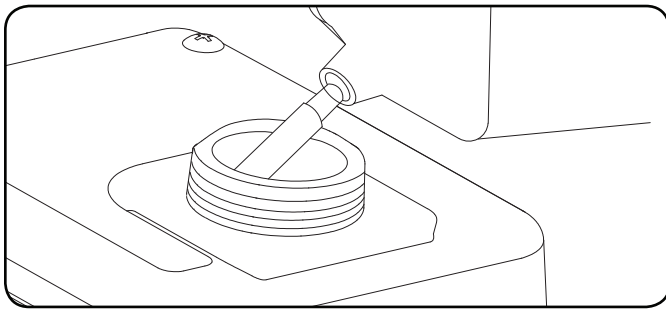

6. Screw on the fuel cap and wipe away any spilled fuel.

WARNING

Pouring fuel too fast through the fuel screen may result in blow back of fuel at the operator while filling.

Add Fuel Cont'd.

CAUTION

Use regular unleaded gasoline with a minimum octane rating of 85.

Do not mix oil and gasoline.

Fill tank to approximately $\frac{1}{4}$ in. (6.4 mm) below the top of the tank to allow for fuel expansion.

DO NOT pump gas directly into the tank at the gas station. Use an approved container to transfer the fuel to the tank.

DO NOT fill fuel tank indoors.

DO NOT fill fuel tank when the engine is running or hot.

DO NOT overfill the fuel tank.

DO NOT light cigarettes or smoke when filling the fuel tank.

NOTE

Our engines work well with 10% or less ethanol blend fuels. When using blended fuels there are some issues worth noting:

- Ethanol-gasoline blends can absorb more water than gasoline alone.
- These blends can eventually separate, leaving water or a watery goo in the tank, fuel valve and carburetor.
- With gravity-fed fuel supplies, this compromised fuel can be drawn into the carburetor and cause damage to the engine and/or potential hazards.
- There are only a few suppliers of fuel stabilizer that are formulated to work with ethanol blend fuels.
- Any damages or hazards caused by using improper fuel, improperly stored fuel, and/or improperly formulated stabilizers, are not covered by manufacture's warranty.

It is advisable to always shut off the fuel supply, run the engine to fuel starvation and drain the tank when the equipment is not in use for more than 30 days.

Before Each Use Inspect the Log Splitter

1. Check the hydraulic oil level and visually inspect all hoses, attachments and cylinder for loose fittings, leaks, cracks, fraying or other damage.
2. DO NOT operate the log splitter if there is any indication of damage.
3. Inspect the engine and make sure the oil level is correct before operating. If the engine is equipped with a spark arrestor, clean and inspect it regularly (follow spark arrestor maintenance schedule).
4. The tires need to be fully inflated and in good repair. Reference the tire sidewall for recommended tire pressure.

WARNING

DO NOT over inflate tires. Serious injury can result if tires explode.
DO NOT tow the log splitter if the tires are worn or will not hold air.
DO NOT exceed the maximum 45 MPH (72 KPH) towing speed.

Towing Log Splitter Safety

1. Always check local and state regulations regarding the requirements for towing, licensing and lights.
2. Before towing make sure the log splitter is correctly and securely attached to the vehicle and the safety chains attached with enough slack to allow for turning.
3. Support leg must be pinned in the "UP" position for towing.
4. Never exceed the max. travel speed of 45 mph. Towing the log splitter at speeds greater than 45 mph could result in serious injury or death. Always adjust your towing speed according to the terrain and conditions.
5. Always disconnect the log splitter from the towing vehicle before operating.

Log Splitter Location

This log splitter must have at least seven feet of clearance from combustible material. Leave at least three feet of clearance on all sides of the log splitter to allow for adequate cooling, maintenance and servicing. DO NOT place the log splitter near vents or intakes where engine exhaust fumes could be drawn into occupied or confined spaces. **ONLY operate the log splitter outdoors.**

Log Splitter Location Cont'd.

The log splitter needs to be on a dry level surface with good footing. DO NOT work on mud, ice, tall grass, brush or snow.

Only operate log splitter from work zones shown below.

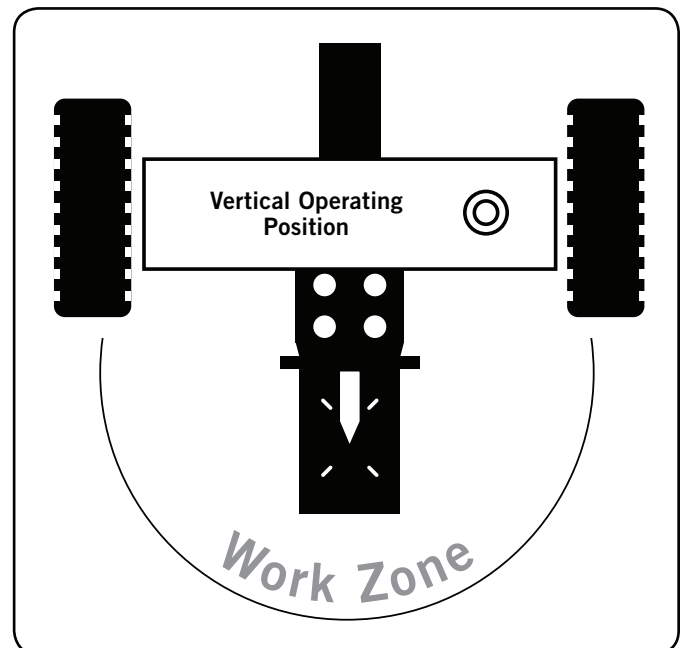
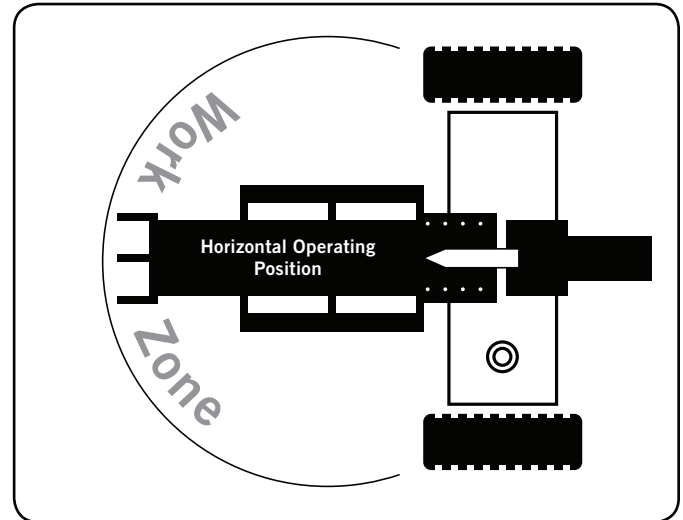

NOTE

For Vertical Operation:

- Remove the beam lock-pin from the beam bracket
- Use handle on cylinder to rotate beam to vertical position
- Insert beam lock-pin in the pivot bracket

OPERATION

Log Splitter Location Cont'd.

WARNING

ALWAYS use the log splitter for its intended use. The log splitter should only be used to split wood logs, length wise with the grain.

NEVER modify, alter or change the log splitter in anyway. Modifications will void the warranty.

NEVER attach a rope, cable or other device to the control lever on the log splitter.

DO NOT modify or change the engine and operating speeds or pressure settings. These changes can cause safety issues.

ONLY operate the log splitter in daylight.

NEVER operate, or let anyone else operate, the log splitter while under the influence of alcohol, drugs, or medication.

NEVER leave the log splitter unattended while the engine is running.

DO NOT change the splitting position with the engine running. Contact with the muffler can cause serious burns.

Always make sure the beam is in the locked position. DO NOT let the beam drop as it could crush fingers or cause damage to the log splitter.

Starting the Engine

1. Make certain the log splitter is on a flat, level surface.
2. Flip engine switch to "ON" position (Item A).
3. Rotate the fuel valve to the "ON" position (Item B).
4. Move the throttle lever (Item C) to the "Fast" position.
5. Move the choke lever (Item D) to the "Choke" position.
6. Pull the starter cord slowly until resistance is felt and then pull rapidly. **SEE NOTE BELOW.**

NOTE

Keep choke lever in "Choke" position for 2 pulls of the recoil starter. After second pull, move choke lever to the "Run" position for up to the next 3 pulls of the recoil starter. Too much choke leads to spark plug fouling/engine flooding due to the lack of incoming air. This will cause the engine not to start.

Starting the Engine Cont'd.

7. As engine warms up, move the choke lever (Item D) to "Run."

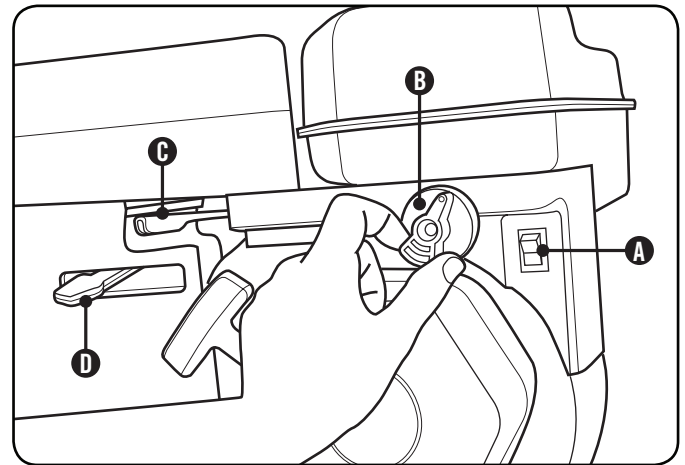

NOTE

If the engine starts but does not run make certain that the log splitter is on a flat, level surface. The engine is equipped with a low oil sensor that will prevent the engine from running when the oil level falls below a critical threshold.

The hydraulic oil needs to be above 10° F (-12° C) before starting the engine. Cold hydraulic oil can damage the hydraulic pump.

If outdoor air temperature is below 32° F (0° C) allow the log splitter to warm up by extending and returning the wedge several times before splitting wood.

Stopping the Engine

1. Turn the fuel knob to the "Off" position. (B)
2. Let the engine run until fuel starvation has stopped the engine. This usually takes a few minutes.
3. Turn the engine switch to the "Off" position. (A)
4. Using your fingers, tighten the hydraulic vent screw by turning it clockwise approximately 2-3 times.

Important: Always ensure that the Fuel Valve and the Engine Switch are in the "OFF" position when the engine is not in use.

NOTE

If the engine will not be used for a period of two (2) weeks or longer, please see the Storage section for proper engine and fuel storage.

Log Splitter Operation

1. ALWAYS wear ear and eye protection, protective clothing and safety gear.

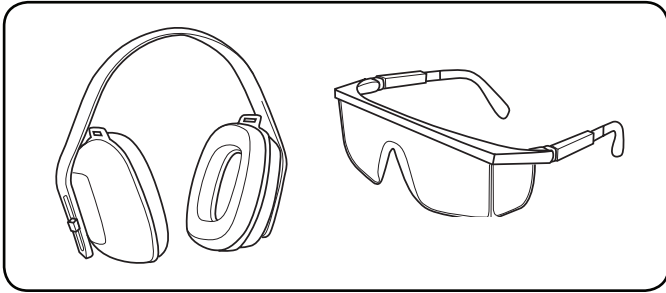

2. Block tires and ensure support leg is secure to prevent unintended movement of the log splitter during operation.
3. Set log splitter in either the horizontal or vertical position.

NOTE

HORIZONTAL position is used for lighter logs that can easily be loaded onto the beam.
VERTICAL position is used for light logs as well as heavy logs that are difficult to load onto the beam. Back injury can result from lifting logs onto the log splitter if proper lifting techniques are not used.

4. Load a log onto the beam against the end plate (MAX LOG LENGTH – 24 in. [61 cm]).
5. Make sure all limbs are clear of crush zones.
6. Push the control valve handle forward (towards the end plate) to split the log.
7. Push the auto control valve handle backward to return the wedge to its original position.
8. Clear the split wood from the work zone.

CAUTION

Do not hold auto control valve in return position. It will damage the stop block or beam.

NOTE

It is normal for the hydraulic fluid to become foamy or frothy during operation.

Log Splitter Operation Cont'd.

NOTE

If a log gets stuck, embedded or will not split completely, push the control handle in the reverse direction and allow the splitter to strip the log from the wedge.
ALWAYS keep hands clear of the log and wedge while it is retracting.

NOTE

The cylinder stroke is designed so the wedge stops approximately 1.5 in. (3.8 cm) from the end plate.

OPERATION

Operation at High Altitude

The density of air at high altitude is lower than at sea level. Engine power is reduced as the air mass and air-fuel ratio decrease. Engine power and output will be reduced approximately 3½% for every 1000 feet of elevation above sea level. This is a natural trend and cannot be changed by adjusting the engine. At high altitudes increased exhaust emissions can also result due to the increased enrichment of the air fuel ratio. Other high altitude issues can include hard starting, increased fuel consumption and spark plug fouling. To alleviate high altitude issues other than the natural power loss, Champion Power Equipment can provide a high altitude carburetor main jet. The alternative main jet and installation instructions can be obtained by contacting Customer Support. Installation instructions are also available in the Technical Bulletin area of the Champion Power Equipment internet site.

The part number and recommended minimum altitude for the application of the high altitude carburetor main jet is listed in the table below.

In order to select the correct high altitude main jet it is necessary to identify the carburetor model. For this purpose, a code is stamped on the side of the carburetor. Select the correct main jet part number corresponding to the carburetor code found on your particular carburetor.

| Carburetor Code | Main Jet | Part Number | Altitude |
|-----------------|----------|-------------------|----------------------------|
| P23-1-Z | Standard | 46.131017.01.Z | 5000 Feet (1524 Meters) |
| | Altitude | 46.131017.01.01.Z | |
| P23-1-H | Standard | 46.131017.01.H | |
| | Altitude | 46.131017.01.01.H | |
| P23-1-Y | Standard | 46.131017.01.Y | |
| | Altitude | 46.131017.01.01.Y | |

WARNING

Operation using the alternative main jet at elevations lower than the recommended minimum altitude can damage the engine. For operation at lower elevations, the standard main jet must be used. Operating the engine with the wrong engine configuration at a given altitude may increase its emissions and decrease fuel efficiency and performance.

The owner/operator is responsible for all periodic maintenance.

WARNING

Never operate a damaged or defective log splitter.

WARNING

Improper maintenance will void your warranty.

NOTE

For service or parts assistance, contact our help line at **1-877-338-0999**.

Complete all scheduled maintenance in a timely manner. Correct any issue before operating the log splitter.

Engine Maintenance

To prevent accidental starting, remove and ground spark plug wire before performing any service.

Oil

Change oil when the engine is warm. Refer to the oil specification to select the proper grade of oil for your operating environment.

1. Remove the oil drain plug with a 15 mm socket and extension.
2. Allow the oil to drain completely.
3. Replace the drain plug.
4. Remove oil fill cap/dipstick to add oil.
5. Add up to 1.2 qt. (1.1 L) of oil and replace oil fill cap/dipstick. **DO NOT OVERFILL.**
6. Dispose of used oil at an approved waste management facility.

NOTE

Once oil has been added, a visual check should show oil about 1-2 threads from running out of the fill hole. If using the dipstick to check oil level, **DO NOT** screw in the dipstick while checking.

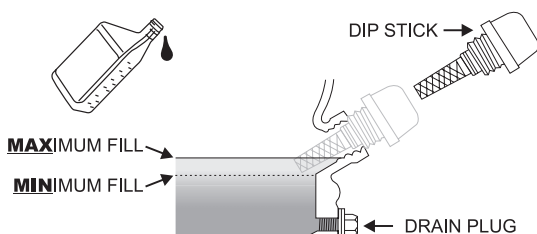

Spark Plugs

1. Remove the spark plug cable from the spark plug.
2. Inspect the electrode on the plug. It must be clean and not worn to produce the spark required for ignition.
3. Make certain the spark plug gap is 0.7 - 0.8 mm (0.028 - 0.031 in.).

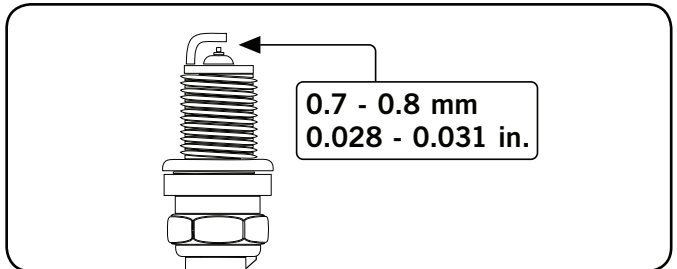

4. Refer to the spark plug recommendation chart when replacing the plug.
5. Carefully thread the plug into the engine.
6. Use the spark plug tool to firmly install the plug.
7. Attach the spark plug wire to the plug.

Air Filter

1. Unscrew wing nut to remove the air filter cover.
2. Unscrew wing nut to remove the air filter.
3. Separate the foam element and the paper element.
4. Tap the paper filter element to remove dirt and debris. Use compressed air (25 PSI) to clear debris.
5. For the foam element: Wash in liquid detergent and water. Squeeze thoroughly dry in a clean cloth.
6. Saturate in clean engine oil.
7. Squeeze in a clean, absorbent cloth to remove all excess oil.
8. Reassemble the two elements and reattach. Tighten wing nut.
9. Reattach the air filter cover and snap in place.

Log Splitter Maintenance

Make certain that the log splitter is kept clean and stored properly. Only operate the unit on a flat, level surface in a clean, dry operating environment. **DO NOT** expose the unit to extreme conditions, excessive dust, dirt, moisture or corrosive vapors.

Inspect all air vents and cooling slots to ensure that they are clean and unobstructed.

Check and tighten all bolts and nuts before operating the log splitter.

Be sure to confirm all hose connections and hose clamps are tight before each use. It is possible for connections to vibrate loose over time.

MAINTENANCE AND STORAGE

Changing the Hydraulic Oil and Oil Filter

NOTE

Install a new hydraulic oil filter each time the hydraulic oil is changed

1. Begin with the cylinder retracted and the engine "OFF."
2. Turn the fuel valve "OFF."
3. Release any stored pressure by moving the valve lever forward and backward several times.
4. Place a container under the hydraulic tank. Make sure it is large enough to hold the contents of the tank.
5. To drain the oil, unscrew and remove the tank drain plug on the bottom of the hydraulic tank.
 - a. Unscrew and remove the hydraulic oil filter.
 - b. Drain any oil in the filter into the container.
6. Allow oil to completely drain from the tank into the container.
7. Install a new hydraulic oil filter. (A)
 - a. Turn the filter counter-clockwise to remove it. A strap wrench may be used.
 - b. Lubricate the gasket of the new filter with a thin film of clean oil.
 - c. Screw the new filter on clockwise. Tighten 3/4 - 1 turn after the gasket makes contact.

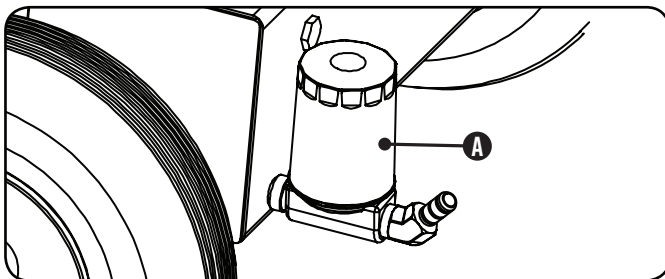

NOTE

The drain plug is sealed with Teflon tape. Add 2-3 wraps of new Teflon tape as needed when replacing the drain plug to prevent oil leak

8. Reinsert and screw in the tank drain plug. Tighten, but do not over tighten.

Changing the Hydraulic Oil and Oil Filter Cont'd.

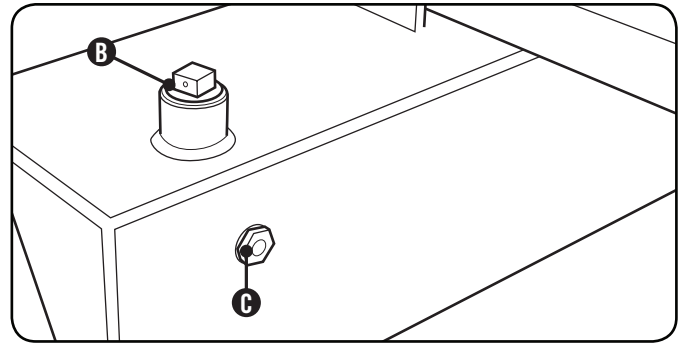

9. Unscrew and remove the tank fill plug, on top of the tank. Using a funnel add approximately 7 gal. (26.5 L) of hydraulic oil to the tank. Wipe up any spilled oil. (B)
10. Turn the fuel valve on, and start the engine. Purge the air from the system by extending and retracting the wedge several times until the motion is smooth.
11. Check the hydraulic oil level using the sight glass. Add 1 to 2 gal. (3.8 to 7.6 L) of hydraulic oil, so the oil level is visible in the sight glass. (C)
12. Dispose of used oil at approved recycling locations.

WARNING

Always shut off the engine, disconnect the spark plug, and relieve system pressure before cleaning, adjusting, or repairing the splitter. Relieve system pressure by moving split control lever back and forth several times

NOTE

Change the hydraulic oil filter after the first 50 hours of use. Then every 100 hours or seasonally.

NOTE

Refer to Specifications for a list of compatible replacement filters or call Champion Power Equipment at 1-877-338-0999 to order a replacement OEM filter.

Cleaning

Clear the debris from the beam, wedge and end plate. Use a damp cloth to clean exterior surfaces of the engine and log splitter. Use a soft bristle brush to remove excess dirt and oil. Use an air compressor (25 PSI) to clear dirt and small debris. Wipe all metal parts with an oily rag to help prevent rust and corrosion.

⚠ CAUTION

DO NOT use a garden hose to clean the engine or log splitter.

Water can contaminate the fuel system and can enter the engine through the cooling slots and damage the engine.

Maintenance Schedule

Follow the service intervals indicated in the schedule below. Service your log splitter more frequently when operating in adverse conditions. Contact our help line at **1-877-338-0999** to locate the nearest Champion Power Equipment authorized service dealer for your log splitter or engine maintenance needs.

| Every 8 hours or daily | |
|---------------------------------|--|
| | Check engine and hydraulic oil levels |
| | Clean around air intake and muffler |
| First 5 Hours | |
| | Change engine oil |
| Every 50 hours or every season | |
| | Clean air filter |
| | Change engine oil if operating under heavy load or in hot environments |
| Every 100 hours or every season | |
| | Change engine oil |
| | Clean/Adjust spark plug |
| | Check/Adjust valve clearance* |
| | Clean fuel tank and filter* |
| | Change hydraulic oil |
| | Change hydraulic oil filter |
| Every 250 hours | |
| | Clean combustion chamber* |
| Every year | |
| | Inspect wheel bearings and repack bearing grease as needed. |
| Every 3 years | |
| | Replace fuel line |

*To be performed by knowledgeable, experienced owners or Champion Power Equipment certified dealers.

Storage

Refer to the Maintenance section for proper cleaning instructions.

Log Splitter Storage

1. The log splitter needs to be cool for at least 5 minutes before storing.
2. Clean the log splitter before storage according to the Maintenance section.
3. Retract the wedge to protect the rod from corrosion.
4. Wipe the beam and wedge with an oily rag to prevent rust and corrosion.

Engine Stored for Less than 30 Days

1. Allow the engine to cool completely before storage.
2. Clean engine according to the Maintenance section.
3. To extend the fuel storage life add fuel stabilizer.
4. Turn the fuel valve to the off position.

Engines Stored for Over 30 Days

1. Run the engine with the fuel valve in the "Off" position until the engine stops.
2. The engine needs to cool completely before storage.
3. Clean engine according to the Maintenance section.
4. Drain all fuel completely from the fuel line and carburetor to prevent gum from forming.
5. Add a fuel stabilizer into the fuel tank.
6. Change the oil.
7. The fuel valve needs to be in the off position.
8. Remove the spark plug and pour about 1/2 ounce (14.8 ml) of oil into the cylinder. Crank the engine slowly to distribute the oil and lubricate the cylinder.
9. Reattach the spark plug.

⚠ WARNING

Never store the log splitter inside next to appliances where there is a source of heat or open flame, spark or pilot light because they can ignite gasoline vapors. **DO NOT** store a log splitter near fertilizer or any corrosive material. Even with an empty gas tank, gasoline vapors could ignite.

TROUBLESHOOTING

| Problem | Cause | Solution |
|--|--|--|
| Engine will not start | No fuel | Add fuel |
| | Faulty spark plug | Replace spark plug |
| | Unit loaded during start up | Remove load from unit |
| Engine will not start; Engine starts but runs roughly | Low oil level | Fill crankcase to the proper level Place log splitter on a flat, level surface |
| | Choke in the wrong position | Adjust choke |
| | Spark plug wire loose | Attach wire to spark plug |
| Engine shuts down during operation | Out of fuel | Fill fuel tank |
| | Low oil level | Fill crankcase to the proper level. Place log splitter on a flat, level surface |
| Engine cannot supply enough power or overheating | Insufficient ventilation | Check for air restriction. Move to a well ventilated area |
| Wedge movement is slow or erratic | Air in the hydraulic oil system | Purge air by extending and retracting the wedge several times until motion is smooth |
| | Debris lodged in beam guides | Clear debris from beam |
| | Low hydraulic oil | Check oil level and add as needed |
| Oil leak from hose connection | Loose hose clamp or hydraulic fitting | Tighten hose clamp or hydraulic fitting |
| Oil leak from cylinder | Faulty cylinder rod seal | Contact Customer Service |
| | Scored or bent cylinder rod | Contact Customer Service |
| | Loose hydraulic fitting | Tighten hydraulic fitting |
| | Faulty combination washer seal on cylinder hydraulic fitting | Contact Customer Service |
| Wedge will not extend or retract | Faulty control valve | Contact Customer Service |
| | Faulty hydraulic pump | Contact Customer Service |
| | Low hydraulic oil | Check oil level and add as needed |
| Wedge does not Auto-Return | Low hydraulic oil | Check oil level and add as needed |
| | Faulty control valve | Contact Customer Service |
| Excessive bouncing while towing | Under-inflated tires | Inflate tires to proper pressure. Refer to tire sidewall |

For further technical support:

Technical Service

Mon – Fri 8:30 AM – 5:00 PM (PST/PDT)

Toll Free: 1-877-338-0999

tech@championpowerequipment.com

Log Splitter Specifications

- Ram Force 35 Ton
- Cycle Time 16 seconds
- Hydraulic Tank Capacity 7 gal. (26.5 L)
- Max Log Length 24 in. (61 cm)
- Max Log Weight 100 lb. (45 kg)
- Coupler Ball Size 2 in. (5.1 cm)
- Tire Size 16 in. (40.6 cm)
- Max towing speed 45 MPH (72 KPH)
- Engine 338 cc, OHV, 4 stroke
- Cylinder size 5 in. x 23 in. (12.7 cm x 58.4 cm)
- Cylinder rod size 1.8 in. (4.5 cm)
- Gear Pump 2-stage
- Max pressure 3600 psi
- Max flow capacity 13 GPM
- Control Valve Detent (auto-return)

Overall Dimensions

- Gross Weight 639.3 lb. (290 kg)
- Net Weight 584.2 lb. (265 kg)
- Height 47 in. (119.4 cm)
- Width 41 in. (104.1 cm)
- Length 86.2 in. (219 cm)

Engine Specifications

- Model YF182F-001
- Displacement 338 cc
- Type 4-Stroke OHV
- Start Type Recoil

Spark Plugs

OEM spark plug: NHSP F6RTC

Replacement spark plug: NGK BPR6ES or equivalent

Make certain the spark plug gap is 0.7 - 0.8 mm or (0.028 - 0.031 in.).

Maintenance Valve Clearance

- Intake: 0.13 – 0.17 mm (0.005 – 0.007 in.)
- Exhaust: 0.18 – 0.22 mm (0.007 – 0.009 in.)

Note: Tech bulletin regarding the valve adjustment procedure is on www.championpowerequipment.com.

Hydraulic Oil System

Oil capacity is 9 gal. (34 L).

Use types 10W AW32, ASLE H-150, ISO32 or universal hydraulic fluid.

Replacement filters:

- **Fram PH9342**
- **K&N HP-2008**
- **Wix 51361**

NOTE

When temperature is below 32° F (0°C) use universal tractor/transmission fluid.

Fuel

Fuel capacity is 1.6 gal. (6.2 L). Use regular unleaded gasoline with a minimum octane rating of 85 and an ethanol content of less than 10% by volume.

Oil

Use 10W-30 automotive oil.

Oil capacity is 1.2 qt. (1.1 L).

DO NOT OVERFILL.

Please reference the following chart for recommended oil types for use in the log splitter.

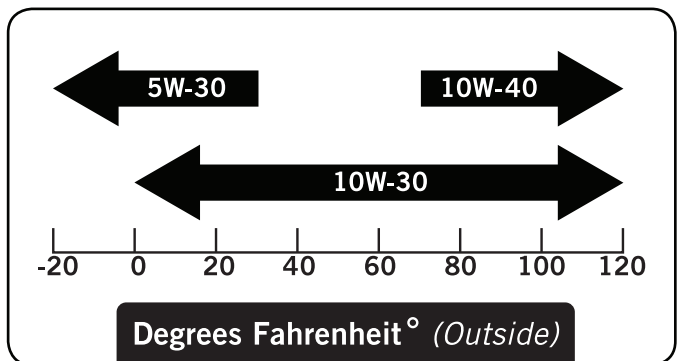

An Important Message About Temperature

Your Champion Power Equipment product is designed and rated for continuous operation at ambient temperatures up to 40°C (104°F). When your product is needed your product may be operated at temperatures ranging from -15°C (5°F) to 50°C (122°F) for short periods. If the product is exposed to temperatures outside this range during storage, it should be brought back within this range before operation. In any event, the product must always be operated outdoors, in a well-ventilated area and away from doors, windows and other vents.

SPECIFICATIONS

Parts Diagram

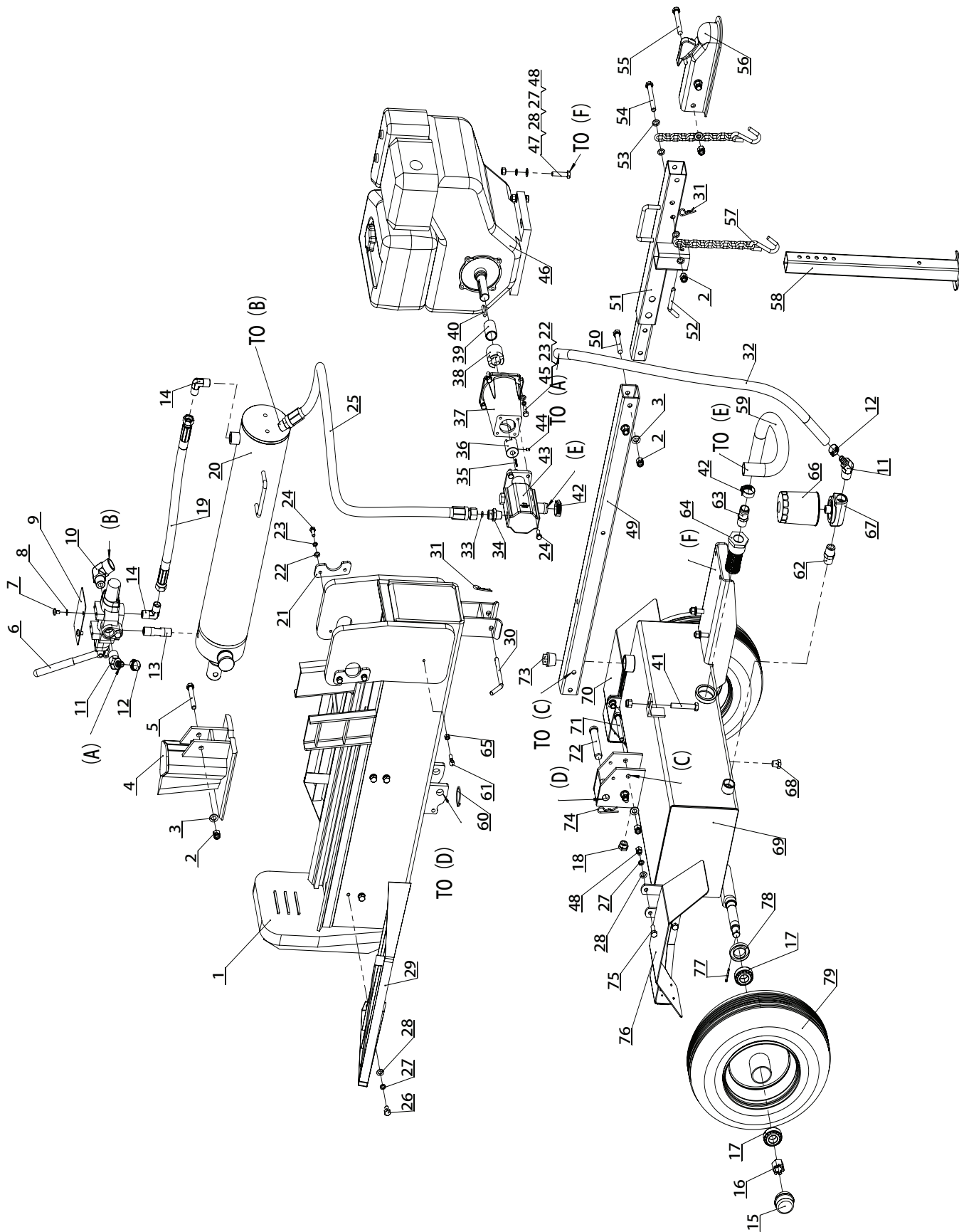

| # | Part Number | Description | Qty |
|----|---------------------------|---------------------------------|-----|
| 1 | PMJ35-02 | Beam | 1 |
| 2 | GB/T 889.1-2000 (M12) | Lock Nut M12 | 8 |
| 3 | GB/T 95-2000 (ø12) | Washer ø12 | 7 |
| 4 | PMJ22J-04-00 | Wedge Slide | 1 |
| 5 | PMJ22J-20 | Bolt | 1 |
| 6 | PMJ22J-12 | Control Valve | 1 |
| 7 | GB/T 818-2000 (M8x12) | Bolt M8x12 | 2 |
| 8 | GB/T 859-1987 (ø8) | Washer ø8 | 2 |
| 9 | PMJ22J-19 | Plate | 1 |
| 10 | PMJ22G-51 | Filter Housing "IN" Connection | 1 |
| 11 | PMJ22G-49 | Filter Housing "OUT" Connection | 2 |
| 12 | JB/T 8870-1999 (d25) | Clamp d25 | 2 |
| 13 | PMJ7-22 | Through Joiner | 1 |
| 14 | PMJ7-15 | Right Angle Joiner | 2 |
| 15 | PMJ22J-05-02 | Axle Cap | 2 |
| 16 | GB/T 9459-1988 (M20x1.5) | Slotted Nut M20x1.5 | 2 |
| 17 | L44634 LYC DS | Tapered Bearing | 4 |
| 18 | GB 1160.2-89 | Oil Scale | 1 |
| 19 | PMJ30-16A | Hydraulic Hose(Valve-Cylinder) | 1 |
| 20 | PMJ35-08A-00 | Cylinder | 1 |
| 21 | PMJ30-03 | Cylinder Fixing Plate | 2 |
| 22 | GB/T 95-2000 (ø8) | Washer ø8 | 8 |
| 23 | GB/T 93-1987 (ø8) | Lock Washer ø8 | 8 |
| 24 | GB/T 5783-2000 (M8x20) | Bolt M8x20 | 8 |
| 25 | PMJ22J-18 | Hydraulic Hose(Valve-Pump) | 1 |
| 26 | GB/T 5781-2000 (M10x15) | Bolt M10x15 | 8 |
| 27 | GB/T 93-1987 (ø10) | Lock Washer ø10 | 16 |
| 28 | GB/T 95-2000 (ø10) | Washer ø10 | 16 |
| 29 | PMJ30F-01-Y | Log Catcher, Yellow | 2 |
| 30 | PMJ22J-15 | Pin | 1 |
| 31 | PMJ22G-30 | R Pin | 2 |
| 32 | PMJ22G-15 | Hydraulic Hose(Valve-Oil Tank) | 1 |
| 33 | GB/T 3452.1-92 (ø10x2.65) | "O" Ring ø10x2.65 | 1 |
| 34 | PMJ22G-21 | Outlet Connector Of Pump | 1 |
| 35 | GB/T 1096-1979 | Flat Key | 1 |
| 36 | PMJ22G-26 | Gear Pump Connector | 1 |
| 37 | PMJ30-23 | Gear Pump Stand | 1 |
| 38 | PMJ30-28 | Engine Connector | 1 |
| 39 | PMJ30-29 | Engine Bushing | 1 |
| 40 | PMJ30-32 | Key | 1 |
| 41 | GB/T 5782-2000 (M12x70) | Bolt M12x70 | 1 |

| # | Part Number | Description | Qty |
|----|-------------------------|------------------------|-----|
| 42 | JB/T 8870 1999 (d40) | Clamp d40 | 2 |
| 43 | PMJ35-10 | Gear Pump | 1 |
| 44 | GB/T 77-2000 (M6x10) | Screw M6x10 | 1 |
| 45 | ASME B18.2.1 1996 | Bolt 5/16"-24x1" | 4 |
| 46 | YF182F-001 | Engine | 1 |
| 47 | GB/T 5780-2000 (M10x45) | Bolt M10x45 | 4 |
| 48 | GB/T 41-2000 (M10) | Nut M10 | 8 |
| 49 | PMJ30-06 | Base Tube | 1 |
| 50 | GB/T 5782-2000 (M12x65) | Bolt M12x65 | 2 |
| 51 | PMJ22J-01-00 | Base Connector | 1 |
| 52 | PMJ22J-10 | Pin | 1 |
| 53 | GB/T 97.2-1985 (ø12) | Washer ø12 | 4 |
| 54 | GB/T 5782-2000 (M12x90) | Bolt M12x90 | 1 |
| 55 | GB/T 5782-2000 (M12x80) | Bolt M12x80 | 2 |
| 56 | PMJ22G-40 | 2 in. Coupler | 1 |
| 57 | PMJ22G-41 | Safety Chain With Hook | 2 |
| 58 | PMJ22J-07-00 | Front Support Leg | 1 |
| 59 | PMJ30-17 | Oil Pipe | 1 |
| 60 | PMJ22G-38 | Big Tension Spring | 1 |
| 61 | GB/T 798-1988 (M8x28) | Swing Bolt M8x28 | 1 |
| 62 | PMJ22Q-23 | Through Joint | 1 |
| 63 | PMJ22Q-22 | Filter Connector | 1 |
| 64 | PMJ22Q-20 | Internal Oil Filter | 1 |
| 65 | GB/T 6170-2000 (M8) | Nut M8 | 1 |
| 66 | PMJ22G-52 | Auto Filter | 1 |
| 67 | PMJ22G-50 | Auto Filter Base | 1 |
| 68 | PMJ22G-19 | Oil Plug | 1 |
| 69 | PMJ30-01A | Oil Tank | 1 |
| 70 | PMJ22G-35-00 | Right Fender | 1 |
| 71 | GB/T 5782-2000 (M12x85) | Bolt M12x85 | 2 |
| 72 | PMJ22G-12 | Hinge Pin | 1 |
| 73 | PMJ22G-18 | Screw NPT1" | 1 |
| 74 | GJY12-3 | R Pin | 1 |
| 75 | GB/T 5781-2000 (M10x30) | Bolt M10x30 | 4 |
| 76 | PMJ22G-34-00 | Left Fender | 1 |
| 77 | GB/T 91-2000 (ø4x32) | Cotter Pin ø4x32 | 2 |
| 78 | PMJ22J-05-01 | Cased Seal | 2 |
| 79 | PMJ22J-05-03 | Wheel | 2 |

SPECIFICATIONS

Engine Parts Diagram

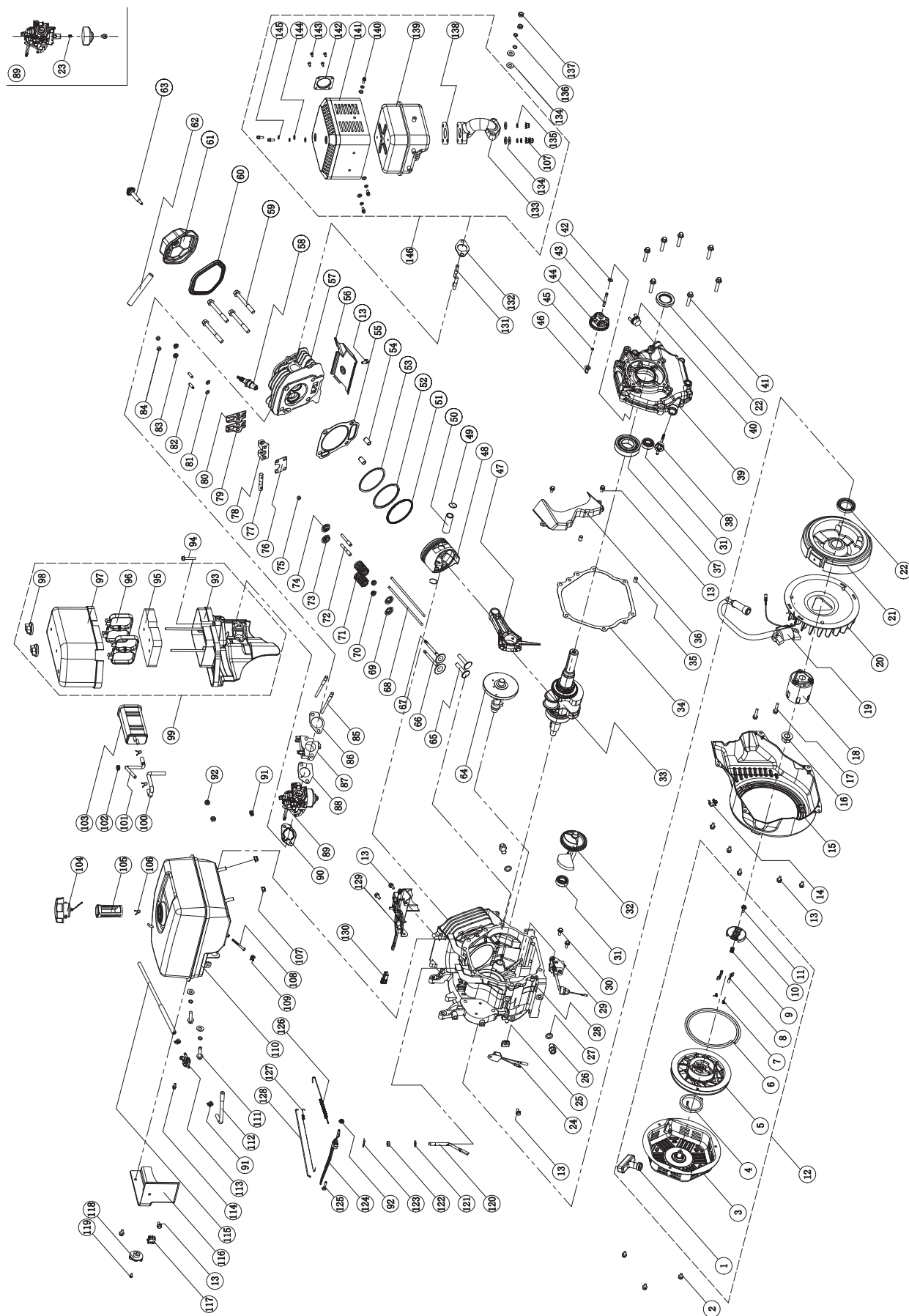

| # | Part Number | Description | Qty |
|----|-----------------|------------------------------------|-----|
| 1 | 21.061300.00 | Recoil Handle | 1 |
| 2 | 1.5789.0608 | Flange Bolt M6x8 | 3 |
| 3 | 46.061100.00.1 | Recoil Starter Cover, Black | 1 |
| 4 | 45.060005.00 | Recoil Starter Spring | 1 |
| 5 | 45.061102.00 | Recoil Starter Reel | 1 |
| 6 | 2.10.003 | Rope (Ø5x1550) | 1 |
| 7 | 45.060003.00 | Spring, Ratchet | 2 |
| 8 | 45.060002.00 | Starter Ratchet (Iron) | 2 |
| 9 | 45.060009.00 | Spring, Ratchet Guide | 1 |
| 10 | 45.060007.00 | Ratchet Guide | 1 |
| 11 | 45.060008.00 | Screw, Ratchet Guide | 1 |
| 12 | 46.061000.00 | Recoil Assembly | 1 |
| 13 | 1.5789.0612 | Flange Bolt M6x12 | 13 |
| 14 | 2.05.003 | Clamp (Ø11.5x10) | 1 |
| 15 | 46.080100.00.48 | Fan Cover, Yellow | 1 |
| 16 | 2.02.007 | Nut (M16x1.5) | 1 |
| 17 | 1.5789.0629 | Flange Bolt M6x29 | 2 |
| 18 | 45.060001.00 | Pulley, Starter | 1 |
| 19 | 46.123000.01 | Ignition Coil | 1 |
| 20 | 45.080001.00 | Cooling Fan | 1 |
| 21 | 46.120100.03 | Flywheel (Manual Start EPA) | 1 |
| 22 | 2.11.007 | Oil Seal (Ø35xØ52x8) | 2 |
| 23 | 46.131017.01 | Standard Main Jet | 1 |
| | 46.131017.01.01 | Altitude Main Jet | / |
| 24 | 21.120400.01 | Diode Assembly | 1 |
| 25 | 45.030032.00 | Sheath, Wire | 1 |
| 26 | 2.08.039 | Drain Bolt (M12x1.5x15) | 2 |
| 27 | 2.03.023 | Washer (Ø12.5xØ20x2) | 2 |
| 28 | 46.030100.00 | Crankcase | 1 |
| 29 | 45.127000.02 | Oil Level Sensor | 1 |
| 30 | 1.5789.0615 | Flange Bolt M6x15 | 2 |
| 31 | 1.276.6202 | Bearing 6202 | 2 |
| 32 | 47.050006.00 | Weight Balancer | 1 |
| 33 | 45.050100.09 | Crankshaft (U) | 1 |
| 34 | 46.030008.00 | Gasket, Crankcase Cover | 1 |
| 35 | 2.04.001 | Dowel Pin (Ø9x14) | 2 |
| 36 | 46.080600.00 | Air Guide, Right Side | 1 |
| 37 | 1.276.6207 | Bearing 6207 | 1 |
| 38 | 46.031000.00.48 | Oil Dipstick Assembly, Yellow | 1 |
| 39 | 45.030007.01 | Cover, Crankcase | 1 |
| 40 | 22.031000.01.48 | Oil Filler Cap, Yellow | 1 |
| 41 | 1.5789.0840.0.8 | Flange Bolt M8x40 | 7 |
| 42 | 2.03.021.1 | Washer (Ø6.4xØ13x1), Black | 1 |
| 43 | 45.110013.00 | Shaft, Governor Gear | 1 |
| 44 | 45.110100.00 | Governor Gear | 1 |
| 45 | 21.110011.00 | Clip, Governor Gear | 1 |
| 46 | 45.110012.00 | Bushing, Governor Gear | 1 |
| 47 | 47.050200.00 | Connecting Rod | 1 |
| 48 | 46.050005.01 | Piston | 1 |
| 49 | 2.09.004 | Circlip (Ø21xØ1) | 2 |
| 50 | 45.050003.00 | Pin, Piston | 1 |
| 51 | 46.050303.01 | Ring, Oil | 1 |
| 52 | 46.050302.01 | Ring, Second Piston | 1 |
| 53 | 46.050301.01 | Ring, First Piston | 1 |
| 54 | 2.04.004 | Dowel Pin (Ø12x20) | 2 |
| 55 | 46.030009.00 | Gasket, Cylinder Head | 1 |
| 56 | 46.080400.00 | Air Guide, Lower | 1 |
| 57 | 46.010100.00 | Cylinder Head | 1 |
| 58 | 2.15.002(F6RTC) | Spark Plug (F6RTC) | 1 |
| 59 | 2.08.014 | Flange Bolt M10x80 | 4 |
| 60 | 46.020002.00 | Gasket, Cylinder Head Cover | 1 |
| 61 | 46.021000.00 | Cylinder Head Cover (CPE) | 1 |
| 62 | 45.020001.00 | Breather Tube | 1 |
| 63 | 45.020100.00 | Bolt, Cylinder Head Cover | 1 |
| 64 | 46.041000.00 | Camshaft (EPA) | 1 |
| 65 | 45.040013.00 | Valve Lifter | 2 |
| 66 | 45.040002.00 | Intake Valve | 1 |
| 67 | 45.040006.00 | Exhaust Valve | 1 |
| 68 | 46.040005.00 | Push Rod | 2 |
| 69 | 45.040015.00 | Retainer, Valve Spring (Down) | 2 |
| 70 | 45.040017.00 | Oil Seal, Valve | 2 |
| 71 | 45.040003.00 | Spring, Valve | 2 |
| 72 | 23.040010.00 | Bolt, Rocker Arm | 2 |
| 73 | 45.040001.00 | Retainer, Intake Valve Spring (Up) | 1 |

| # | Part Number | Description | Qty |
|-----|-----------------|-------------------------------------|-----|
| 74 | 45.040007.00 | Retainer, Exhaust Valve Spring (Up) | 1 |
| 75 | 45.040008.00 | Rotator, Exhaust Valve | 1 |
| 76 | 46.040004.00 | Guide Plate, Push Rod | 1 |
| 77 | 46.040016.00 | Shaft, Rocker Arm | 1 |
| 78 | 46.040201.00 | Retainer, Rocker Arm | 1 |
| 79 | 46.040009.00 | Rocker Arm, Intake Valve | 1 |
| 80 | 46.040018.00 | Rocker Arm, Exhaust Valve | 1 |
| 81 | 1.97.1.06 | Washer Ø6 | 2 |
| 82 | 22.040012.00 | Screw, Valve Adjustment | 2 |
| 83 | 1.6177.1.06 | Flange Lock Nut M6 | 2 |
| 84 | 21.040021.00 | Lock Nut (M6x0.5) | 2 |
| 85 | 2.01.013 | Stud Bolt (M6xM8x131) | 2 |
| 86 | 46.130002.20 | Gasket, Insulator | 1 |
| 87 | 45.130001.01 | Insulator, Carburetor | 1 |
| 88 | 46.130003.00 | Gasket, Carburetor | 1 |
| 89 | 46.131000.01 | Carburetor | 1 |
| | 46.131000.03 | | |
| 90 | 45.130004.00 | Gasket, Air Cleaner | 1 |
| 91 | 2.06.007 | Clip (Ø8xb6) | 3 |
| 92 | 1.6177.06 | Flange Nut (M6) | 3 |
| 93 | 46.091100.01 | Base, Air Cleaner | 1 |
| 94 | 1.5789.0633 | Flange Bolt M6x33 | 1 |
| 95 | 46.091003.02 | Element, Air Cleaner | 1 |
| 96 | 46.091102.02 | Supporter, Air Cleaner | 2 |
| 97 | 46.091200.02 | Cover, Air Cleaner | 1 |
| 98 | 46.091600.01 | Screw Cap, Air Cleaner Cover | 2 |
| 99 | 46.091000.02 | Air Cleaner Assembly | 1 |
| 100 | 46.070013.00 | Pipe, Air Cleaner | 1 |
| 101 | 46.070014.00 | Pipe | 1 |
| 102 | 2.12.001 | Buffer (Ø7.5x7.5) | 1 |
| 103 | 46.070700.00 | Carbon Canister | 1 |
| 104 | 24.070100.02 | Fuel Tank Cap | 1 |
| 105 | 46.070300.00 | Fuel Filter Component (Large) | 1 |
| 106 | 2.06.006 | Clamp (Ø7xØ1) | 3 |
| 107 | 1.6187.1.08 | Nut M8 | 5 |
| 108 | 111.070300.01 | Fuel Filter Component (Small) | 1 |
| 109 | 2.06.018 | Clip (Ø10.5xb8) | 1 |
| 110 | 46.071000.01.1 | Fuel Tank, Black | 1 |
| 111 | 1.5789.0832 | Flange Bolt M8x32 | 2 |
| 112 | 46.070011.00 | Pipe (Fuel Tank To Fuel Cock) | 1 |
| 113 | 24.070400.00 | Fuel Cock | 1 |
| 114 | 1.16674.0512.2 | Flange Bolt M5x12 | 1 |
| 115 | 46.070011.01 | Pipe (Fuel Cock To Carburetor) | 1 |
| 116 | 46.070010.00 | Fuel tank veil | 1 |
| 117 | 5.1010.003.3 | Flameout Switch | 1 |
| 118 | 24.070001.00 | Fuel Cock Knob | 1 |
| 119 | 1.818.0412 | Bolt M4X12 | 1 |
| 120 | 45.110001.00 | Shaft, Governor Arm | 1 |
| 121 | 2.03.019 | Washer (Ø8.2xØ17x0.8) | 1 |
| 122 | 2.11.006 | Oil Seal (Ø7xØ14x5) | 1 |
| 123 | 45.110008.00 | Pin, Shaft | 1 |
| 124 | 45.110003.00 | Governor Arm | 1 |
| 125 | 2.08.040 | Bolt, Governor Arm(M6x21) | 1 |
| 126 | 45.110007.00 | Governor Spring | 1 |
| 127 | 45.110005.00 | Spring, Throttle Return | 1 |
| 128 | 45.110006.00 | Governor Rod | 1 |
| 129 | 46.080300.00 | Air Guide, Upper | 1 |
| 130 | 24.111008.01.48 | Sheath, Grip | 1 |
| 131 | 2.01.005 | Stud Bolt (M8x49) | 2 |
| 132 | 46.100001.07 | Gasket, Exhaust Pipe | 1 |
| 133 | 46.101001.05 | Exhaust Pipe | 1 |
| 134 | 1.848.08 | Washer Ø8 | 7 |
| 135 | 1.859.08 | Spring Washer Ø8 | 5 |
| 136 | 1.93.08 | Spring Washer Ø8 | 2 |
| 137 | 1.6175.08 | Nut M8 | 2 |
| 138 | 46.101002.05 | Washer, Muffler | 1 |
| 139 | 46.101100.05 | Muffler | 1 |
| 140 | 1.16674.0510 | Flange Bolt M5x10 | 5 |
| 141 | 46.101202.05 | Muffler Protector | 1 |
| 142 | 46.101300.05 | Spark Arrester | 1 |
| 143 | 1.818.046 | Screw M4x6 | 4 |
| 144 | 1.848.05 | Washer Ø5 | 5 |
| 145 | 1.859.05 | Spring Washer Ø5 | 5 |
| 146 | 46.101000.05.2 | Muffler Assembly | 1 |

WARRANTY

WARRANTY*

CHAMPION POWER EQUIPMENT
2 YEAR LIMITED WARRANTY

Warranty Qualifications

Champion Power Equipment (CPE) will register this warranty upon receipt of your Warranty Registration Card and a copy of your sales receipt from one of CPE's retail locations as proof of purchase. Please submit your warranty registration and your proof of purchase within ten (10) days of the date of purchase.

Repair/Replacement Warranty

CPE warrants to the original purchaser that the mechanical and electrical components will be free of defects in material and workmanship for a period of two years (parts and labor) from the original date of purchase and 180 days (parts and labor) for commercial and industrial use. Transportation charges on product submitted for repair or replacement under this warranty are the sole responsibility of the purchaser. This warranty only applies to the original purchaser and is not transferable.

Do Not Return The Unit To The Place Of Purchase

Contact CPE's Technical Service and CPE will troubleshoot any issue via phone or e-mail. If the problem is not corrected by this method, CPE will, at its option, authorize evaluation, repair or replacement of the defective part or component at a CPE Service Center. CPE will provide you with a case number for warranty service. Please keep it for future reference. Repairs or replacements without prior authorization, or at an unauthorized repair facility, will not be covered by this warranty.

Warranty Exclusions

This warranty does not cover the following repairs and equipment:

Normal Wear

Products with mechanical and electrical components need periodic parts and service to perform well. This warranty does not cover repair when normal use has exhausted the life of a part or the equipment as a whole.

Installation, Use and Maintenance

This warranty will not apply to parts and/or labor if the product is deemed to have been misused, neglected, involved in an accident, abused, loaded beyond the product's limits, modified, installed improperly or connected incorrectly to any electrical component. Normal maintenance is not covered by this warranty and is not required to be performed at a facility or by a person authorized by CPE.

Other Exclusions

This warranty excludes:

- Cosmetic defects such as paint, decals, etc.
- Wear items such as filter elements, o-rings, etc.
- Accessory parts such as starting batteries, and storage covers.
- Failures due to acts of God and other force majeure events beyond the manufacturer's control.
- Problems caused by parts that are not original Champion Power Equipment parts.

When applicable, this warranty does not apply to products used for prime power in place of a utility.

Limits of Implied Warranty and Consequential Damage

Champion Power Equipment disclaims any obligation to cover any loss of time, use of this product, freight, or any incidental or consequential claim by anyone from using this product. THIS WARRANTY AND THE ATTACHED U.S. EPA, CARB and/or ECCC EMISSION CONTROL SYSTEM WARRANTIES (WHEN APPLICABLE) ARE IN LIEU OF ALL OTHER WARRANTIES, EXPRESS OR IMPLIED, INCLUDING WARRANTIES OF MERCHANTABILITY OR FITNESS FOR A PARTICULAR PURPOSE.

A unit provided as an exchange will be subject to the warranty of the original unit. The length of the warranty governing the exchanged unit will remain calculated by reference to the purchase date of the original unit.

This warranty gives you certain legal rights which may change from state to state or province to province. Your state or province may also have other rights you may be entitled to that are not listed within this warranty.

Contact Information

Address

Champion Power Equipment, Inc.
Customer Service
12039 Smith Ave.
Santa Fe Springs, CA 90670 USA
www.championpowerequipment.com

Customer Service

Mon – Fri 8:30 AM – 5:00 PM (PST/PDT)
Toll Free: 1-877-338-0999
info@championpowerequipment.com
Fax no.: 1-562-236-9429

Technical Service

Mon – Fri 8:30 AM – 5:00 PM (PST/PDT)
Toll Free: 1-877-338-0999
tech@championpowerequipment.com
24/7 Tech Support: 1-562-204-1188

*Except as otherwise stipulated in any of the following enclosed Emission Control System Warranties (when applicable) for the Emission Control System: U.S. Environment Protection Agency (EPA), California Air Resources Board (CARB) and/or Environment and Climate Change Canada (ECCC).

**Champion Power Equipment, Inc. (CPE),
The United States Environment Protection Agency (U.S. EPA.) and the California Air Resources Board (CARB)
Emission Control System Warranty**

Your Champion Power Equipment (CPE) engine complies with both the U.S. EPA and state of California Air Resources Board (CARB) emission regulations.

YOUR WARRANTY RIGHTS AND OBLIGATIONS:

The US EPA, California Air Resources Board, and CPE are pleased to explain the Federal and California Emission Control Systems Warranty on your 2016 small off-road engine and engine powered equipment. In California, new, small off-road engines and new equipment that use small off-engines must be designed, built and equipped to meet the State's stringent anti smog standards. In the other states, new engines and equipment must be designed, built and equipped, at the time of sale, to meet U.S. EPA regulations for small non-road engines. CPE warrants the emission control system on your small off-road engine and equipment for the period of time listed below, provided there has been no abuse, neglect, unapproved modification, or improper maintenance of your equipment.

Your emission control system may include parts such as the carburetor, fuel-injection system, the ignition system, catalytic converter and fuel lines. Also included may be hoses, belts, connectors and other emission related assemblies. Where a warrantable condition exists, CPE will repair your small off-road engine at no cost to you including diagnosis, parts and labor. For engines less than or equal to 80cc, only the fuel tank and fuel line is subject to the evaporative emission control warranty requirements of this section.

MANUFACTURER'S EMISSION CONTROL SYSTEM WARRANTY COVERAGE:

This emission control system is warranted for two years, subject to provisions set forth below. If, during the warranty period, emission related part on your engine is defective in materials or workmanship, the part will be repaired or replaced by CPE.

OWNER WARRANTY RESPONSIBILITIES:

As the small off-road engine owner, you are responsible for the performance of the required maintenance listed in your Owner's Manual. CPE recommends that you retain all your receipts covering maintenance on your small off-road engine, but CPE cannot deny warranty solely for the lack of receipts or for your failure to ensure the performance of all scheduled maintenance.

As the small off-road engine owner, you should however be aware that CPE may deny you warranty coverage if your small, off-road engine or a part has failed due to abuse, neglect, improper maintenance or unapproved modifications.

You are responsible for presenting your small off-road engine to an Authorized CPE service outlet or alternate service outlet as described in (3)(f.) below, CPE dealer or CPE, Santa Fe Springs, Ca. as soon as a problem exists. The warranty repairs should be completed in a reasonable amount of time, not to exceed 30 days.

If you have any questions regarding your warranty rights and responsibilities, you should contact:

Champion Power Equipment, Inc.
Customer Service
12039 Smith Ave.
Santa Fe Springs, CA 90670
1-877-338-0999
tech@championpowerequipment.com

EMISSION CONTROL SYSTEM WARRANTY

The following are specific provisions relative to your Emission Control System (ECS) Warranty Coverage.

1. APPLICABILITY: This warranty shall apply to 1995 and later model year California small off-road engines (for other states, 1997 and later model year engines). The ECS Warranty Period shall begin on the date the new engine or equipment is delivered to its original, end-use purchaser, and shall continue for 24 consecutive months thereafter.

2. GENERAL EMISSIONS WARRANTY COVERAGE

CPE warrants to the original, end-use purchaser of the new engine or equipment and to each subsequent purchaser that each of its small off-road engines is:

a. Designed, built and equipped so as to conform to U.S. EPA emissions standards for spark-ignited engines at or below 19 kilowatts and all applicable regulations adopted by the California Air Resources Board and

b. Free from defects in materials and workmanship that cause the failure of a warranted part to be identical in all material respects to the part as described in the engine manufacturer's application for certification for a period of two years.

3. THE WARRANTY ON EMISSION-RELATED PARTS WILL BE INTERPRETED AS FOLLOWS:

a. Any warranted part that is not scheduled for replacement as required maintenance in the Owners Manual shall be warranted for the ECS Warranty Period. If any such part fails during the ECS Warranty Period, it shall be repaired or replaced by CPE according to Subsection "d" below. Any such part repaired or replaced under the ECS Warranty shall be warranted for any remainder of the ECS Warranty Period.

b. Any warranted, emissions-related part which is scheduled only for regular inspection as specified in the Owners Manual shall be warranted for the ECS Warranty Period. A statement in such written instructions to the effect of "repair or replace as necessary", shall not reduce the ECS Warranty Period. Any such part repaired or replaced under the ECS Warranty shall be warranted for the remainder of the ECS Warranty Period.

c. Any warranted, emissions-related part which is scheduled for replacement as required maintenance in the Owner's Manual shall be warranted for the period of time prior to the first scheduled replacement point for that part. If the part fails prior to the first scheduled replacement, the part shall be repaired or replaced by CPE according to Subsection "d" below. Any such emissions-related part repaired or replaced under the ECS Warranty, shall be warranted for the remainder of the ECS Warranty Period prior to the first scheduled replacement point for such emissions-related part.

d. Repair or replacement of any warranted, emissions-related part under this ECS Warranty shall be performed at no charge to the owner at a CPE Authorized Service Outlet.

e. The owner shall not be charged for diagnostic labor which leads to the determination that a part covered by the ECS Warranty is in fact defective, provided that such diagnostic work is performed at a CPE Authorized Service Outlet.

f. CPE shall pay for covered emissions warranty repairs at non-authorized service outlets under the following circumstances:

i. The service is required in a population center with a population over 100,000 according to U.S. Census 2000 without a CPE Authorized Service Outlet AND

ii. The service is required more than 100 miles from a CPE Authorized Service Outlet. The 100 mile limitation does not apply in the following states: Alaska, Arizona, Colorado, Hawaii, Idaho, Montana, Nebraska, Nevada, New Mexico, Oregon, Texas, Utah and Wyoming.

g. CPE shall be liable for damages to other original engine components or approved modifications proximately caused by a failure under warranty of an emission-related part covered by the ECS Warranty.

h. Throughout the ECS Warranty Period, CPE shall maintain a supply of warranted emission-related parts sufficient to meet the expected demand for such emission-related parts.

i. Any CPE Authorized and approved emission-related replacement part may be used in the performance of any ECS Warranty maintenance or repair and will be provided without charge to the owner. Such use shall not reduce CPE's warranty obligation.

j. Unapproved add-on or modified parts may not be used to modify or repair a CPE engine. Such use voids this ECS Warranty and shall be sufficient grounds for disallowing an ECS Warranty claim. CPE shall not be liable hereunder for failures of any warranted parts of a CPE engine caused by the use of such an unapproved add-on or modified part.

EMISSION-RELATED PARTS INCLUDE THE FOLLOWING: (using those portions of the list applicable to the engine)

| Systems covered by this warranty | Parts Description |
|----------------------------------|--|
| Fuel Metering System | Fuel regulator, Carburetor and internal parts |
| Air Induction System | Air cleaner, Intake manifold |
| Ignition System | Spark plug and parts, Magneto ignition system |
| Exhaust System | Exhaust manifold, catalytic converter |
| Miscellaneous Parts | Tubing, Fittings, Seals, Gaskets, and Clamps associated with these listed systems. |
| Evaporative Emissions | Fuel Tank, Fuel Cap, Fuel Line, Fuel Line Fittings, Clamps, Pressure Relief Valves, Control Valves, Control Solenoids, Electronic Controls, Vacuum Control Diaphragms, Control Cables, Control Linkages, Purge Valves, Vapor Hoses, Liquid/Vapor Separator, Carbon Canister, Canister Mounting Brackets, Carburetor Purge Port Connector |

TO OBTAIN WARRANTY SERVICE:

You must take your CPE engine or the product on which it is installed, along with your warranty registration card or other proof of original purchase date, at your expense, to any Champion Power Equipment dealer who is authorized by Champion Power Equipment, Inc. to sell and service that CPE product during his normal business hours. Alternate service locations defined in Section (3)(f.) above must be approved by CPE prior to service. Claims for repair or adjustment found to be caused solely by defects in material or workmanship will not be denied because the engine was not properly maintained and used.

If you have any questions regarding your warranty rights and responsibilities, or to obtain warranty service, please write or call Customer Service at Champion Power Equipment, Inc.

**Champion Power Equipment, Inc.
12039 Smith Ave.
Santa Fe Springs, CA 90670
1-877-338-0999
Attn.: Customer Service
tech@championpowerequipment.com**