

CHAMPION

POWER EQUIPMENT™

OWNER'S MANUAL & OPERATING INSTRUCTIONS



22 Ton LOG SPLITTER

*Log Catcher sold separately.

1 YEAR
LIMITED WARRANTY

MODEL NUMBER
92207

SAVE THESE INSTRUCTIONS
Important Safety Instructions
are included in this manual.

MADE IN CHINA
REV 92207-20160927

10006 Santa Fe Springs Road
Santa Fe Springs CA 90670
USA / 1-877-338-0999
www.championpowerequipment.com

Have questions or need assistance?

Do not return this product to the store!

WE ARE HERE TO HELP!

Visit our website:

www.championpowerequipment.com

for more info:

- Product Info & Updates
- Tech Bulletins
- Frequently Asked Questions
- Product Registration

– or –

Call our Customer Care Team Toll-Free at:

1-877-338-0999

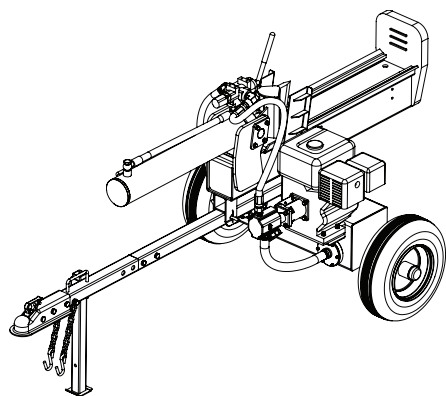

22 Ton LOG SPLITTER

TABLE OF CONTENTS

Introduction	1	Specifications	14
Introduction	1	Log Splitter Specifications	14
Portable Log Splitter	1	Hydraulic Oil	14
Accessories	1	Engine Specifications	14
This Booklet	1	Fuel	14
Manual Conventions	2	Oil	14
Safety Rules	3	Spark Plugs	14
Controls and Features	5	Valve Clearance	14
Log Splitter	5	Parts Diagram	15
Assembly	6	Parts List	16
Open Shipping Crate	6	Engine Parts Diagram	17
1) Install Engine	6	Engine Parts List	18
2) Assemble Tow Bar	6	Troubleshooting	19
3) Attach Beam	6	Warranty	20
4) Attach Hydraulic Cylinder	6	Warranty Qualifications	20
Add Engine Oil	7	Repair/Replacement Warranty	20
Add Engine Fuel	7	Do Not Return The Unit To	
Operation	8	The Place Of Purchase	20
Before Each Use Inspect the Log Splitter	8	Warranty Exclusions	20
Towing Log Splitter Safety	8	Normal Wear	20
Log Splitter Location	8	Installation, Use and Maintenance	20
Starting the Engine	9	Other Exclusions	20
Stopping the Engine	9	Limits of Implied Warranty and Consequential	
Log Splitter Operation	10	Damage	20
Adjustable Stop Pin (ASP)	10	Contact Information	20
Install the ASP	10	Address	20
Maintenance and Storage	11	Customer Service	20
Engine Maintenance	11	Technical Service	20
Oil	11		
Spark Plugs	11		
Air Filter	11		
Cleaning	11		
Maintenance Schedule	12		
Log Splitter Maintenance	12		
Changing the Hydraulic Oil and Oil Filter			
Storage	13		
Log Splitter Storage	13		
Engine stored for Less than 30 Days	13		
Engines Stored for Over 30 Days	13		

INTRODUCTION

Introduction

Congratulations on your purchase of a Champion Power Equipment log splitter. CPE designs and builds log splitters to strict specifications. With proper use and maintenance, this log splitter will bring years of satisfying service.

Portable Log Splitter

This unit is a gasoline engine driven hydraulic log splitter. It is designed to split wood logs for use as fire wood for a stove or fire place. This log splitter will only split logs lengthwise, with the grain only.

Accessories

Champion Power Equipment manufactures and sells accessories designed to help you get the most from your purchase. To find out more please visit our website at:
→ www.championpowerequipment.com

This Booklet

Every effort has been made to ensure the accuracy and completeness of the information in this manual. We reserve the right to change, alter and/or improve the product and this document at any time without prior notice.

Record the model and serial numbers as well as date and place of purchase for future reference. Have this information available when ordering parts and when making technical or warranty inquiries.

Champion Power Equipment Support
1-877-338-0999
Model Number
92207
Serial Number
Date of Purchase
Purchase Location
For Oil Type see "Add Engine Oil" section. For Fuel Type see "Add Fuel" section.

This manual uses the following symbols to help differentiate between different kinds of information. The safety symbol is used with a key word to alert you to potential hazards in operating and owning power equipment.

Follow all safety messages to avoid or reduce the risk of serious injury or death.

 **DANGER**

DANGER indicates an imminently hazardous situation which, if not avoided, **will** result in death or serious injury.

 **WARNING**

WARNING indicates a potentially hazardous situation which, if not avoided, **could** result in death or serious injury.

 **CAUTION**

CAUTION indicates a potentially hazardous situation which, if not avoided, **may** result in minor or moderate injury.

CAUTION

CAUTION used without the safety alert symbol indicates a potentially hazardous situation which, if not avoided, **may** result in property damage.

 **NOTE**

If you have questions regarding your log splitter, we can help. Please call our help line at **1-877-338-0999**

SAFETY RULES

WARNING

Read this manual thoroughly before operating your log splitter. Failure to follow instructions could result in serious injury or death.

WARNING

The engine exhaust from this product contains chemicals known to the state of California to cause cancer, birth defects, or other reproductive harm.

DANGER

Log Splitter engine exhaust contains carbon monoxide, a colorless, odorless, poison gas. Breathing carbon monoxide will cause nausea, dizziness, fainting or death. If you start to feel dizzy or weak, get to fresh air immediately.

Operate log splitter outdoors only in a well ventilated area. DO NOT operate the log splitter inside any building, enclosure or compartment. DO NOT allow exhaust fumes to enter a confined area through windows, doors, vents or other openings. **DANGER CARBON MONOXIDE**, using a log splitter indoors **CAN KILL YOU IN MINUTES**.

DANGER

Rotating parts can entangle hands, feet, hair, clothing and/or accessories. Traumatic amputation or severe laceration can result.

Keep hands and feet away from rotating parts. Tie up long hair and remove jewelry. Operate equipment with guards in place. DO NOT wear loose-fitting clothing, dangling drawstrings or items that could become caught.

WARNING

Projectile Hazard

Pieces of log may be ejected from the splitter while operating. **Wear ANSI approved safety glasses when operating. Be alert.**

DANGER

Sparks can result in fire or electrical shock.

When servicing the engine:

Disconnect the spark plug wire and place it where it cannot contact the plug. DO NOT check for spark with the plug removed. Use only approved spark plug testers.

WARNING

Running engines produce heat. Severe burns can occur on contact. Combustible material can catch fire on contact.

DO NOT touch hot surfaces. Avoid contact with hot exhaust gases. Allow equipment to cool before touching. Maintain at least three feet of clearance on all sides to ensure adequate cooling. Maintain at least five feet of clearance from combustible materials.

WARNING

Crush Hazard

Wedge can cut through skin and break bones. Keep all limbs away from wedge and endplate.

WARNING

Keep Operator Work Zone Clear

Keep work zone clear of debris while working to ensure safe footing.

WARNING

Engine exhaust, some of its constituents, and certain vehicle components contain or emit chemicals known to the State of California to cause cancer and birth defects or other reproductive harm.

⚠ WARNING

This product contains chemicals, including lead, known to the State of California to cause cancer, and birth defects or other reproductive harm. Wash hands after handling.

⚠ DANGER

Skin Injection Hazard. High pressure hydraulic oil can inject under your skin.

Make sure all fittings are tightly secure before applying pressure. Relieve system of pressure before servicing.

⚠ WARNING**Towing Hazard**

ALWAYS check all local and state regulations regarding towing, licensing and lights before towing your log splitter. Review towing safety warnings in your towing vehicle manual.

Drive safely. Be aware of the added length of the log splitter. NEVER ride or transport cargo on the log splitter. Choose a level surface to operate the log splitter.

NEVER EXCEED MAX. Towing Speed 45 MPH (72 KPH)

⚠ WARNING

Rapid retraction of the starter cord will pull hand and arm towards the engine faster than you can let go. Unintentional startup can result in entanglement, traumatic amputation or laceration. Broken bones, fractures, bruises or sprains could result.

When starting engine, pull the starter cord slowly until resistance is felt and then pull rapidly to avoid kickback.

⚠ CAUTION

Parts of the hydraulic circuit (cylinder, pump, valve-body, hoses) can become very hot during operation.

⚠ DANGER

Fuel and fuel vapors are highly flammable and extremely explosive.

Fire or explosion can cause severe burns or death. Unintentional startup can result in entanglement, traumatic amputation or laceration.

When adding or removing fuel:

Turn the engine off and let it cool for at least two minutes before removing the fuel cap. Loosen the cap slowly to relieve pressure in the tank. Only fill or drain fuel outdoors in a well-ventilated area. DO NOT overfill the fuel tank. Always keep fuel away from sparks, open flames, pilot lights, heat and other sources of ignition. DO NOT light or smoke cigarettes.

When starting the engine:

DO NOT attempt to start a damaged engine. Make certain that the gas cap, air filter, spark plug, fuel lines and exhaust system are properly in place. Allow spilled fuel to evaporate fully before attempting to start the engine.

Make certain that the log splitter is resting firmly on level ground.

When operating the log splitter:

DO NOT move or tip the log splitter during operation.

DO NOT tip the log splitter or allow fuel or oil to spill from the engine. Block the wheels to prevent unintended movement.

When storing the log splitter:

Store away from sparks, open flames, pilot lights, heat and other sources of ignition.

⚠ CAUTION

Improper treatment or use of the log splitter can damage it, shorten its life and void your warranty.

Use the log splitter only for intended uses. Operate only on level surfaces. DO NOT expose log splitter to excessive moisture, dust, or dirt.

DO NOT allow any material to block the cooling slots. DO NOT use the engine if:

- Equipment sparks, smokes or emits flames
- Equipment vibrates excessively

CONTROLS AND FEATURES

Read this owner's manual before operating your log splitter. Familiarize yourself with the location and function of the controls and features. Save this manual for future reference.

Log Splitter

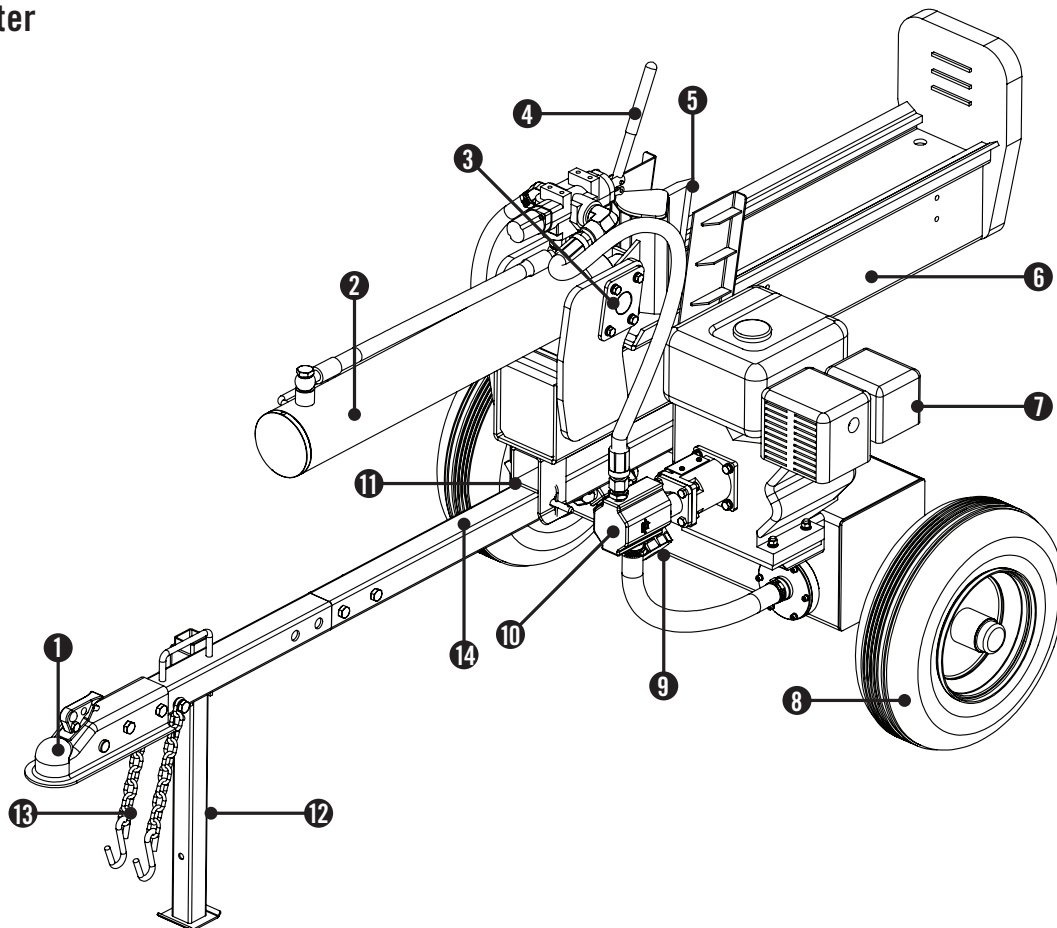

- | | |
|---|--|
| <p>(1) 2" Ball Coupler – For towing the log splitter behind your vehicle.</p> <p>(2) Hydraulic Cylinder – 4" bore (10.16 cm) x 22.63" (57.5 cm) stroke. Rated to 3500 psi.</p> <p>(3) Mounting Plates – Holds hydraulic cylinder in place.</p> <p>(4) Control Valve Handle – Controls the movement of the cutting wedge.</p> <p>(5) Wedge</p> <p>(6) Splitting Beam</p> | <p>(7) Engine – 196cc, OHV, 4-stroke, air cooled.</p> <p>(8) Tires – Maximum travel speed is 45 MPH (72 KPH).</p> <p>(9) Hydraulic Fluid Filter</p> <p>(10) Hydraulic Pump – Pumps hydraulic oil through the system.</p> <p>(11) Beam Bracket – Holds splitting beam in place.</p> <p>(12) Support Leg – Supports log splitter while operating. Raise leg for towing.</p> <p>(13) Safety Chains – For use while towing.</p> <p>(14) Auto Stop Pin (ASP) – Limits the return stroke of the splitting wedge.</p> |
|---|--|

Your log splitter requires some assembly. If you have any questions regarding the assembly of your log splitter, call our help line at 1-877-338-0999. Please have your serial number and model number available.

Open Shipping Crate

1. Set the shipping crate on a solid, flat surface
2. Carefully cut the shipping bands and remove lid of shipping crate.
3. Locate all hardware before beginning assembly.

1) Install Engine (Figure A)

1. Unbolt engine from the shipping bracket.
2. Place engine on mounting bracket on hydraulic oil tank and secure with four M8x45 bolts, M8 washers, M8 lock washers and M8 nuts. Tighten engine bolts to 17 ft-lb.
3. Discard engine shipping bracket.

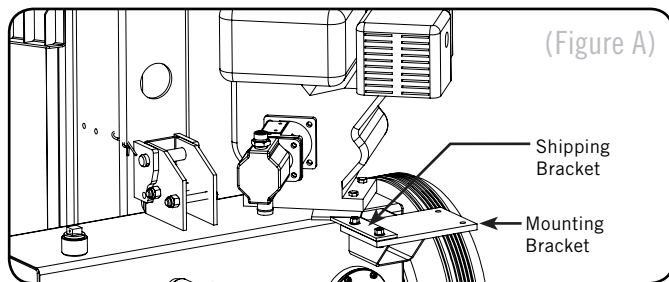

2) Assemble Tow Bar (Figure B)

1. Locate and fit together the two segments of the tow bar and secure with the two M12x65 bolts, M12 washers and M12 lock nuts provided. (A)
2. Remove two sets of bolts and nuts from the back of the tow bar (on opposite side of 2" ball coupler) and attach tow bar to bracket on top of hydraulic oil tank using the two M12x85 bolts and M12 nuts just removed from the end of the tow bar. (B)
3. Locate and insert the front foot into the sliding bracket on the front of the tow bar using pin provided. (C)

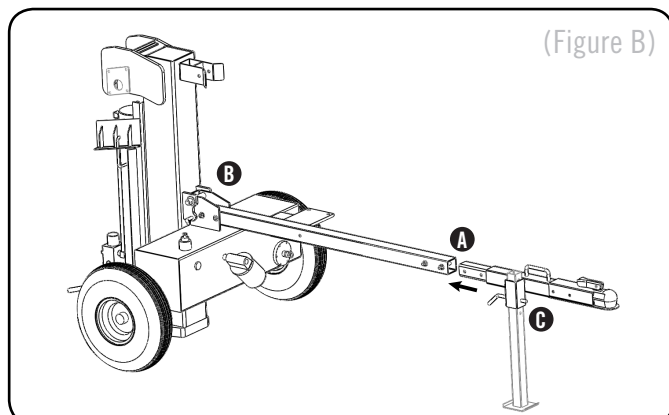

3) Attach Beam

1. Remove pin from bracket on top of beam and lower into horizontal position over the tow bar.

CAUTION

The hydraulic cylinder is only cradled in the splitting beam and is NOT secure. Lower the beam carefully making sure the hydraulic cylinder stays in place.

2. Pin the beam into place on top of the tow bar.

NOTE

Using two people the log splitter may be lowered off the pallet to allow for more room for assembly.

4) Attach Hydraulic Cylinder (Figure C)

1. Remove each of the two cylinder mounting plates on either side of the cylinder mounting slots on top of the splitting beam by removing the four M8x20 bolts, M8 washers, M8 lock washers and M8 lock nuts. (A)
2. Temporarily remove the cylinder from the top of the splitting beam and slide the wedge into the channel on top of the splitting beam. (B)
3. Slide the cylinder into the mounting slots on top of the beam. The cylinder will rest in position without additional support. (C)
4. Replace the mounting plates and secure the cylinder into position with the bolts removed in Step 1. (D)
5. Remove the M12x75 bolt, M12 washer, and M12 lock nut from the cylinder rod, slide the wedge back into position. Align and secure the wedge with bolt removed from cylinder rod. (E)

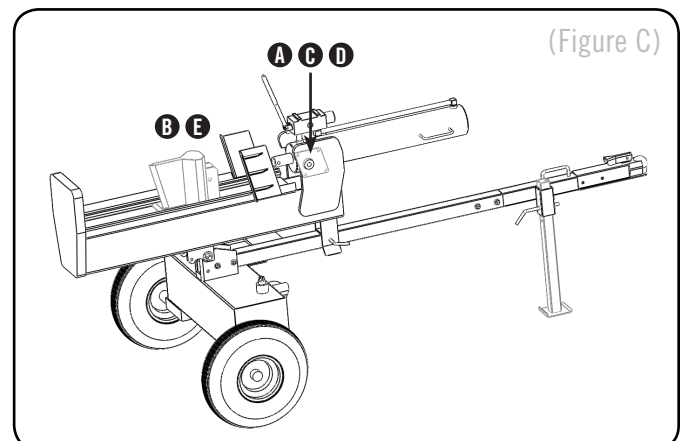

ASSEMBLY

Add Hydraulic Oil

1. Make sure the log splitter is on a flat, level surface.
2. Remove the oil plug from the oil tank. (A)
3. Add 5 gal. (18.9 L) of hydraulic oil - 10W AW32, ASLE H-150, or ISO 32 are all acceptable types of fluid.
4. Check the hydraulic oil level using the oil sight glass. Oil level should be centered on the glass sight. (B)
5. Replace and tighten the oil plug and orient the vent hole away from the operator zone.

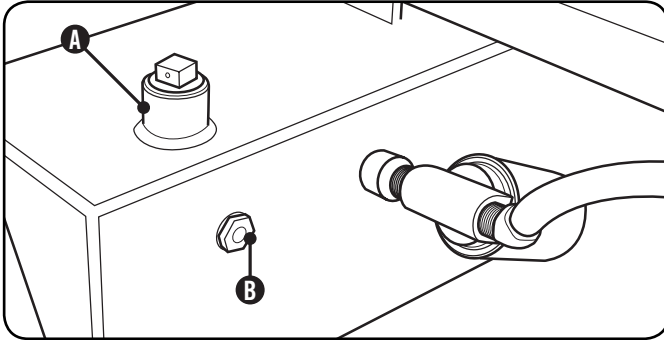

⚠ WARNING

DO NOT remove the hydraulic oil fill cap when the engine is running or hot. Hot oil can escape causing severe burns. Always allow the log splitter to cool completely before removing the hydraulic oil cap.

High fluid pressure and temperatures are created in the hydraulic log splitters. Hydraulic fluid will escape through a pin-size hole opening and can puncture skin and cause severe blood poisoning.

Inspect hydraulic system regularly for possible leaks. Never check for leaks with your hand while the system is pressurized. Seek medical attention immediately if injured by escaping fluid.

6. Start Engine. Extend and retract the wedge to purge air from the hydraulic system. When the wedge motion is smooth, the system is properly purged.

Add Engine Oil

⚠ CAUTION

DO NOT attempt to crank or start the engine before it has been properly filled with the recommended type and amount of oil. Damage to the log splitter as a result of failure to follow these instructions will void your warranty.

1. Make sure the log splitter is on a flat, level surface.
2. Remove oil fill cap/dipstick to add oil.
3. Add 0.63 qt (0.6 L) of oil (SAE 10W-30) - oil should cover all but 2 threads of filler hole. Replace oil fill cap/dipstick.
4. Check engine oil level daily and add as needed.

Add Engine Oil Cont'd.

CAUTION

The engine is equipped with a low-oil-shutoff and the will stop when the oil level in the crankcase falls below the threshold level.

NOTE

Check oil often during the break-in period. Refer to the Maintenance section for recommended service intervals.

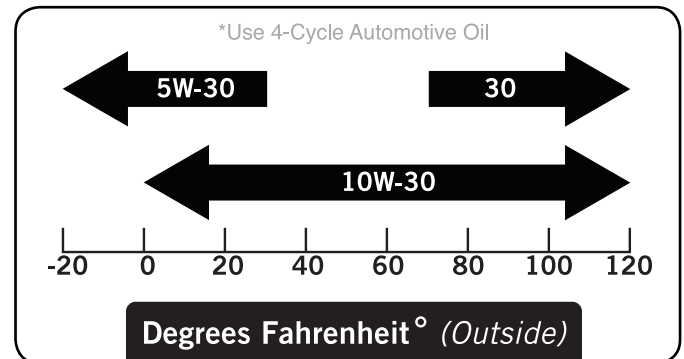

Add Engine Fuel

1. Use clean, fresh, regular unleaded fuel with a minimum octane rating of 85 and an ethanol content of less than 10% by volume.
2. DO NOT mix oil with fuel.
3. Clean the area around the fuel cap.
4. Remove the fuel cap.
5. Slowly add fuel to the tank. DO NOT overfill. Allow approximately ¼ inch of space for fuel expansion.
6. Screw on the fuel cap and wipe away any spilled fuel.

⚠ CAUTION

Use regular unleaded gasoline with a minimum octane rating of 85.

Do not mix oil and gasoline.

Fill tank to approximately ¼ inch below the top of the tank to allow for fuel expansion.

DO NOT fill fuel tank indoors.

DO NOT fill fuel tank when the engine is running or hot.

DO NOT overfill the fuel tank.

DO NOT light cigarettes or smoke when filling the fuel tank.

Before Each Use Inspect the Log Splitter

1. Check the hydraulic oil level and visually inspect all hoses, attachments and cylinder for loose fittings, leaks, cracks, fraying or other damage.
2. DO NOT operate the log splitter if there is any indication of damage.
3. Inspect the engine and make sure the oil level is correct before operating. If the engine is equipped with a spark arrestor, clean and inspect it regularly (follow spark arrestor maintenance schedule).
4. The tires need to be fully inflated and in good repair. Reference the tire sidewall for recommended tire pressure.

WARNING

DO NOT over inflate tires. Serious injury can result if tires explode.
DO NOT tow the log splitter if the tires are worn or will not hold air.
DO NOT exceed the maximum 45 MPH (72 KPH) towing speed.

Towing Log Splitter Safety

1. Always check local and state regulations regarding the requirements for towing, licensing and lights.
2. Before towing make sure the log splitter is correctly and securely attached to the vehicle and the safety chains attached with enough slack to allow for turning.
3. Never exceed the max. travel speed of 45 mph. Towing the log splitter at speeds greater than 45 mph could result in serious injury or death. Always adjust your towing speed according to the terrain and conditions.
4. Always disconnect the log splitter from the towing vehicle before operating.

Log Splitter Location

This log splitter must have at least seven feet of clearance from combustible material. Leave at least three feet of clearance on all sides of the log splitter to allow for adequate cooling, maintenance and servicing. DO NOT place the log splitter near vents or intakes where engine exhaust fumes could be drawn into occupied or confined spaces. **Always operate the log splitter outdoors.**

The log splitter needs to be on a dry level surface with good footing. DO NOT work on mud, ice, tall grass, brush or snow.

Only operate log splitter from work zone shown below.

Log Splitter Location Cont'd.

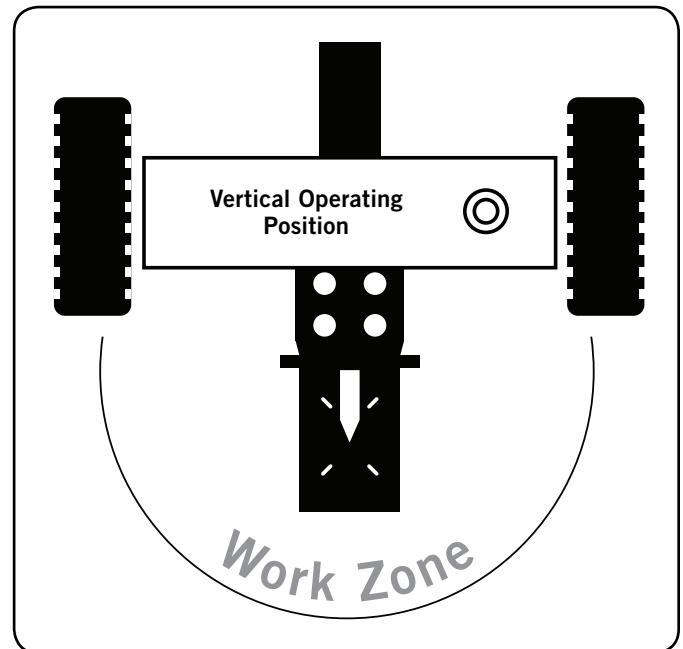
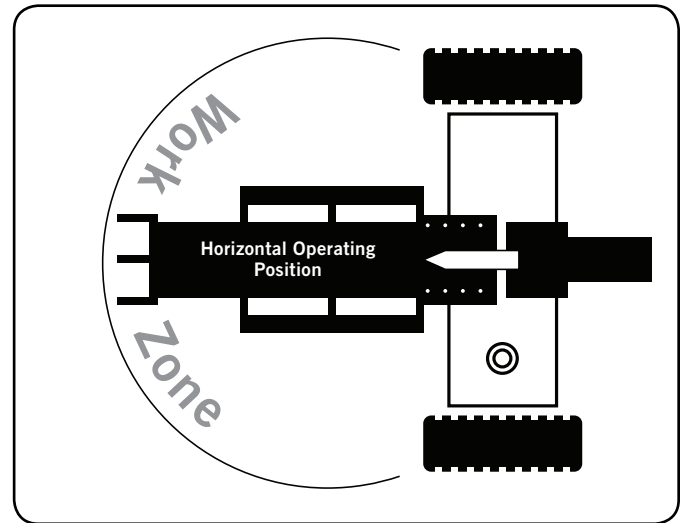

OPERATION

Log Splitter Location Cont'd.

WARNING

ALWAYS use the log splitter for its intended use. The log splitter should only be used to split wood logs, length wise with the grain.

NEVER modify, alter or change the log splitter in anyway. Modifications will void the warranty.

NEVER attach a rope, cable or other device to the control lever on the log splitter.

DO NOT modify or change the engine and operating speeds or pressure settings. These changes can cause safety issues.

ONLY operate the log splitter in daylight.

NEVER operate, or let anyone else operate, the log splitter while under the influence of alcohol, drugs, or medication.

NEVER leave the log splitter unattended while the engine is running.

DO NOT change the splitting position with the engine running. Contact with the muffler can cause serious burns.

Always make sure the beam is in the locked position.

DO NOT let the beam drop as it could crush fingers or cause damage to the log splitter.

Starting the Engine

1. Make certain the log splitter is on a flat, level surface.
2. Flip engine switch to "ON" position (Item A).
3. Rotate the fuel valve to the "ON" position (to the left) (Item B).
4. Move the choke lever (Item C) to the "Choke" position (to the left).
5. Pull the starter cord slowly until resistance is felt and then pull rapidly. **SEE NOTE BELOW.**

NOTE

Keep choke lever in "Choke" position for only 1 pull of the recoil starter. After first pull, move choke lever to the "Run" position for up to the next 3 pulls of the recoil starter. Too much choke leads to spark plug fouling/engine flooding due to the lack of incoming air. This will cause the engine not to start.

6. As engine warms up, move the choke lever (Item C) to "Run" (to the right).
7. Move the throttle lever (Item D) to the "Fast" position.

Starting the Engine Cont'd.

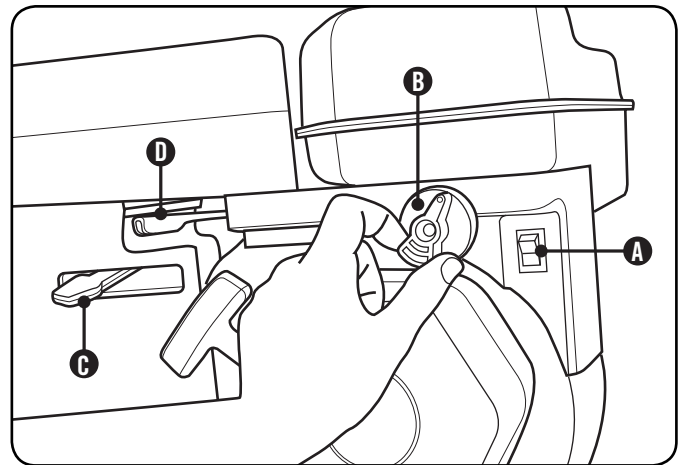

NOTE

If the engine starts but does not run make certain that the log splitter is on a flat, level surface. The engine is equipped with a low oil sensor that will prevent the engine from running when the oil level falls below a critical threshold.

The hydraulic oil needs to be above 10° F (-12° C) before starting the engine. Cold hydraulic oil can damage the hydraulic pump.

If outdoor air temperature is below 32° F (0° C) allow the log splitter to warm up by extending and returning the wedge several times before splitting wood.

Stopping the Engine

1. Turn the ignition switch to the "Off" position.
2. Turn the fuel knob to the "Off" position.

Log Splitter Operation

1. ALWAYS wear ear and eye protection, protective clothing and safety gear.

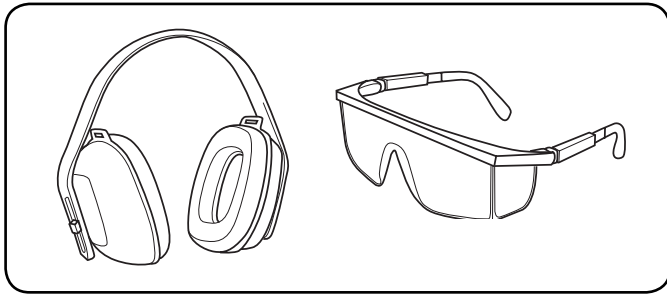

2. Block tires and put both support legs in the DOWN position to prevent unintended movement of the log splitter during operation.
3. Set log splitter in either the horizontal or vertical position.

NOTE

HORIZONTAL position is used for lighter logs that can easily be loaded onto the beam.
VERTICAL position is used for light logs as well as heavy logs that are difficult to load onto the beam. Back injury can result from lifting logs onto the log splitter if proper lifting techniques are not used.

4. Load a log onto the beam against the end plate (MAX LOG LENGTH – 23.75" [60.3 cm]).
5. Make sure all limbs are clear of crush zones.
6. Push the control valve handle forward (towards the end plate) to split the log.
7. Push the auto control valve handle backward to return the wedge to its original position.
8. Clear the split wood from the work zone.

CAUTION

Do not hold auto control valve in return position. It will damage the stop block or beam.

NOTE

It is normal for the hydraulic fluid to become foamy or frothy during operation.

Adjustable Stop Pin (ASP)

The ASP can be positioned on the I-Beam behind the wedge to limit the return stroke of the splitting wedge. This feature can be used to shorten the cycle time when splitting shorter logs. The ASP can be positioned for logs less than 16" long, and less than 20" long. The ASP is stored on the tow bar under the cylinder.

Install the ASP

1. Start the engine.
2. Extend the wedge until the desired ASP hole are visible on the top of the I-Beam.
3. Turn the engine OFF.
4. Place ASP in the holes at the desired position (16" or 20").
5. The ASP is held in place by the internal ball detent.

NOTE

If a log gets stuck, embedded or will not split completely, push the control handle in the reverse direction and allow the splitter to strip the log from the wedge.
ALWAYS keep hands clear of the log and wedge while it is retracting.

CAUTION

The ASP is a wear item. It should be checked each time the log splitter is used and must be replaced if there are any signs of wear.

MAINTENANCE AND STORAGE

The owner/operator is responsible for all periodic maintenance.

WARNING

Never operate a damaged or defective log splitter.

WARNING

Improper maintenance will void your warranty.

NOTE

For service or parts assistance, contact our help line at **1-877-338-0999**.

Complete all scheduled maintenance in a timely manner. Correct any issue before operating the log splitter.

Engine Maintenance

To prevent accidental starting, remove and ground spark plug wire before performing any service.

Oil

Change oil when the engine is warm. Refer to the oil specification to select the proper grade of oil for your operating environment.

1. Remove the oil drain plug with a 12 mm socket and extension.
2. Allow the oil to drain completely.
3. Replace the drain plug.
4. Remove oil fill cap/dipstick to add oil.
5. Add 0.63 qt (0.6 L) of oil and replace oil fill cap/dipstick.
6. Dispose of used oil at an approved waste management facility.

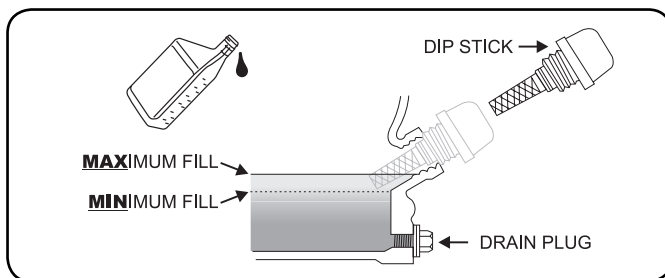

Spark Plugs

1. Remove the spark plug cable from the spark plug.
2. Inspect the electrode on the plug. It must be clean and not worn to produce the spark required for ignition.
3. Make certain the spark plug gap is 0.7 - 0.8 mm (0.028 - 0.031 in.).
4. Refer to the spark plug recommendation chart when replacing the plug.
5. Carefully thread the plug into the engine.
6. Use the spark plug tool to firmly install the plug.
7. Attach the spark plug wire to the plug.

Air Filter

1. Remove the snap-on cover holding the air filter to the assembly.
2. Remove the foam element.
3. Wash in liquid detergent and water. Squeeze thoroughly dry in a clean cloth.
4. Saturate in clean engine oil.
5. Squeeze in a clean, absorbent cloth to remove all excess oil.
6. Place the filter in the assembly.
7. Reattach the air filter cover and snap in place.

Cleaning

CAUTION

DO NOT use a garden hose to clean the engine or log splitter.

Water can contaminate the fuel system and can enter the engine through the cooling slots and damage the engine.

Clear the debris from the beam, wedge and end plate. Use a damp cloth to clean exterior surfaces of the engine and log splitter. Use a soft bristle brush to remove excess dirt and oil. Use an air compressor (25 PSI) to clear dirt and small debris. Wipe all metal parts with an oily rag to help prevent rust and corrosion.

Maintenance Schedule

Follow the service intervals indicated in the schedule below. Service your log splitter more frequently when operating in adverse conditions. Contact our help line at **1-877-338-0999** to locate the nearest Champion Power Equipment authorized service dealer for your log splitter or engine maintenance needs.

Every 8 hours or daily	
	Check engine and hydraulic oil level
	Clean around air intake and muffler
First 5 Hours	
	Change engine oil
Every 50 hours or every season	
	Clean air filter
	Change engine oil if operating under heavy load or in hot environments
Every 100 hours or every season	
	Change engine and hydraulic oil
	Clean/Adjust spark plug
	Check/Adjust valve clearance *
	Clean spark arrester
	Clean fuel tank and filter *
Every 3 years	
	Replace fuel line

*To be performed by knowledgeable, experienced owners or Champion Power Equipment certified dealers.

Log Splitter Maintenance

Make certain that the log splitter is kept clean and stored properly. Only operate the unit on a flat, level surface in a clean, dry operating environment. DO NOT expose the unit to extreme conditions, excessive dust, dirt, moisture or corrosive vapors.

Inspect all air vents and cooling slots to ensure that they are clean and unobstructed.

Clean Spark arrester every 100 hours

Check and tighten all bolts and nuts before operating the log splitter.

Changing the Hydraulic Oil and Oil Filter

NOTE

Install a new hydraulic oil filter each time the hydraulic oil is changed

Changing the Hydraulic Oil and Oil Filter Cont'd.

1. Begin with the cylinder retracted and the engine "OFF."
2. Turn the fuel valve "OFF."
3. Release any stored pressure by moving the valve lever forward and backward several times.
4. Place a container under the hydraulic tank. Make sure it is large enough to hold the contents of the tank.
5. To drain the oil, unscrew and remove the tank drain plug on the bottom of the hydraulic tank.
 - a. Unscrew and remove the hydraulic oil filter.
 - b. Drain any oil in the filter into the container.
6. Allow oil to completely drain from the tank into the container.
7. Install a new hydraulic oil filter. (A)
 - a. Turn the filter counter-clockwise to remove it. A strap wrench may be used.
 - b. Lubricate the gasket of the new filter with a thin film of clean oil.
 - c. Screw the new filter on clockwise. Tighten 3/4 - 1 turn after the gasket makes contact.
8. Reinsert and screw in the tank drain plug. Tighten, but do not over tighten.

NOTE

The drain plug is sealed with Teflon tape. Add 2-3 wraps of new Teflon tape as needed when replacing the drain plug to prevent oil leak

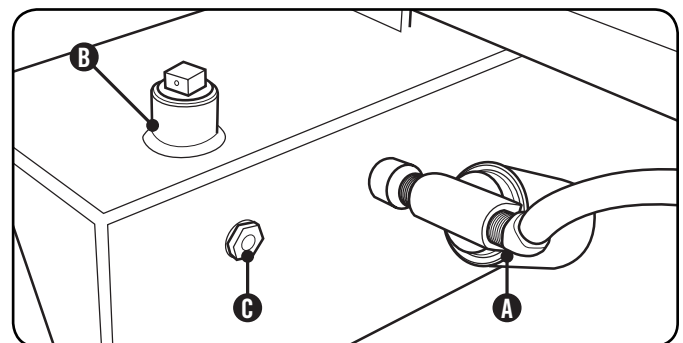

9. Unscrew and remove the tank fill plug, on top of the tank. Using a funnel add approximately 4 gal. (15.1 L) of hydraulic oil to the tank. Wipe up any spilled oil. (B)
10. Turn the fuel valve on, and start the engine. Purge the air from the system by extending and retracting the wedge several times until the motion is smooth.

MAINTENANCE AND STORAGE

Changing the Hydraulic Oil and Oil Filter Cont'd.

11. Check the hydraulic oil level using the sight glass.
Add 1 - 1.5 gal. (3.8 – 5.7 L) of hydraulic oil, so the oil level is visible in the sight glass. (C)
12. Dispose of used oil at approved recycling locations.

WARNING

Always shut off the engine, disconnect the spark plug, and relieve system pressure before cleaning, adjusting, or repairing the splitter. Relieve system pressure by moving split control lever back and forth several times

NOTE

Change the hydraulic oil filter after the first 50 hours of use. Then every 100 hours or seasonally.

NOTE

Refer to Specifications for a list of compatible replacement filters or call Champion Power Equipment at 1-877-338-0999 to order a replacement OEM filter.

Storage

Refer to the Maintenance section for proper cleaning instructions.

Log Splitter Storage

1. The log splitter needs to be cool for at least 5 minutes before storing.
2. Clean the log splitter before storage according to the Maintenance section.

Log Splitter Storage Cont'd.

3. Retract the wedge to protect the rod from corrosion.
4. Wipe the beam and wedge with an oily rag to prevent rust and corrosion.

Engine stored for Less than 30 Days

1. Allow the engine to cool completely before storage.
2. Clean engine according to the Maintenance section.
3. To extend the fuel storage life add fuel stabilizer.
4. Turn the fuel valve to the off position.

Engines Stored for Over 30 Days

1. Run the engine with the fuel valve in the “Off” position until the engine stops.
2. The engine needs to cool completely before storage.
3. Clean engine according to the Maintenance section.
4. Drain all fuel completely from the fuel line and carburetor to prevent gum from forming.
5. Add a fuel stabilizer into the fuel tank.
6. Change the oil.
7. The fuel valve needs to be in the off position.
8. Remove the spark plug and pour about 1/2 ounce of oil into the cylinder. Crank the engine slowly to distribute the oil and lubricate the cylinder.
9. Reattach the spark plug.

WARNING

Never store the log splitter inside next to appliances where there is a source of heat or open flame, spark or pilot light because they can ignite gasoline vapors. DO NOT store a log splitter near fertilizer or any corrosive material. Even with an empty gas tank, gasoline vapors could ignite.

Log Splitter Specifications

- Ram Force 22 Ton
- Cycle Time 14 seconds
- Hydraulic Tank Capacity 5 gal (18.9 L)
- Max Log Length 23.75 inches (60.3 cm)
- Max Log Weight 100 lb. (45 kg)
- Coupler Ball Size 2 inches (5 cm)
- Tire Size 15 inches (38 cm)
- Max towing speed 45 MPH (72 KPH)
- Engine 196 cc, OHV, 4 stroke
- Cylinder size 4" x 22.63" (10 cm x 57.5 cm)
- Cylinder rod size 1.57 inches (4 cm)
- Hydraulic Fluid Type 10W AW32,
ASLE H-150, ISO 32
- Gear Pump 2-stage
- Max pressure 3500 psi
- Max flow capacity 11 GPM
- Control Valve Detent (auto-return)
- **Overall Dimensions**
- Gross Weight 482.8 lb. (219 kg)
- Net Weight 441 lb. (200 kg)
- Height 45.87 inches (116.5 cm)
- Width 40.75 inches (103.5 cm)
- Length 85.83 inches (218 cm)

Engine Specifications

- Engine 196 cc OHV CPE
- PTO Rotation Counterclockwise
- Ignition Mode TCI (transistorized)
- Displacement 196 cc
- Torque (max) 8.7 ft. lb. @ 2800 RPM
- Compression 8.5:1
- Horizontal Shaft ¾" x 2 7/16"
(1.91 cm x 6.17 cm)
- End Hole Tapped 5/16" 24 UNF
- Fuel Capacity 0.93 gallons (3.5 L)
- Weight 37.5 lb. (17 kg)
- Height 13.35 inches (33.9 cm)
- Width 12.13 inches (30.8 cm)
- Length 14.25 inches (36.2 cm)

Hydraulic Oil

Oil capacity is 5 gallons (18.9 L).

Use types 10W AW32, ASLE H-150, ISO32 or universal hydraulic fluid.

Replacement filters:

- **Fram PH9342**
- **K&N HP-2008**
- **Wix 51361**

Fuel

Fuel capacity is 0.93 gallons (3.5 L). Use regular unleaded gasoline with a minimum octane rating of 85 and an ethanol content of less than 10% by volume.

Oil

Use 4-Cycle automotive oil.

Oil capacity is 0.63 qt (0.6 L).

Please reference the following chart for recommended oil types for use in the log splitter.

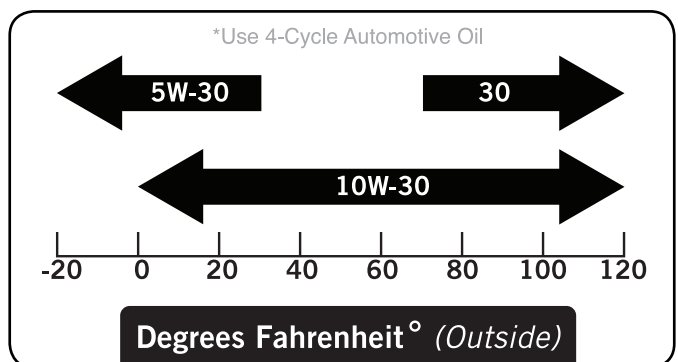

Spark Plugs

Recommended replacement spark plug:

- **NGK BR6ES or equivalent**

Make certain the spark plug gap is 0.7 - 0.8 mm or (0.028 - 0.031 in.).

Valve Clearance

- Intake: 0.13 – 0.15 mm (0.005 – 0.006 in.)
- Exhaust: 0.18 – 0.20 mm (0.007 – 0.008 in.)

SPECIFICATIONS

Parts Diagram

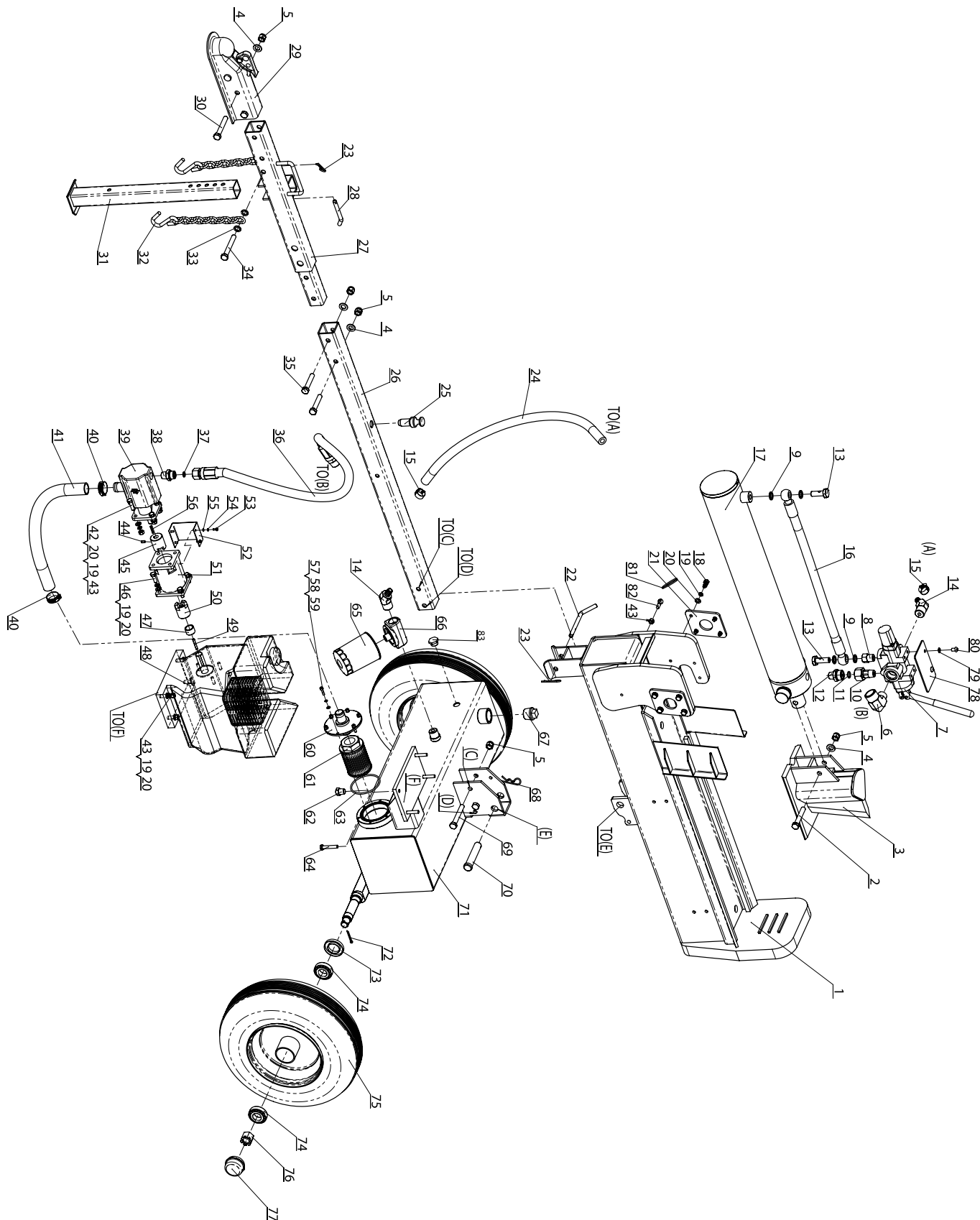

#	Part number	Description	Qty
1	PMJ22J-02-00	Beam	1
2	GB/T 5782-2000	BOLT M12×75 (12.9)	1
3	PMJ22J-04-00	Wedge Slide	1
4	GB/T 95-2000	Washer 12 mm	7
5	GB/T 889.1-2000	Lock Nut M12	8
6	PMJ22G-51	Filter Housing "IN" Connection	1
7	PMJ22J-12	Control Valve	1
8	PMJ22G-24	Valve Joiner	1
9	JB 982-1977	Combination Washer 14 mm	4
10	PMJ22G-25	Valve Joiner	1
11	GB3452.1-92	"O" Ring 14×2.65	1
12	PMJ22G-22	Front Cover Connector	1
13	PMJ22G-23	Bolt Connector	2
14	PMJ22G-49	Filter Housing "OUT" Connection	2
15	JB/T 8870 1999	Clamp D25	2
16	PMJ22G-16	Hydraulic Hose (Valve-Cylinder)	1
17	PMJ22J-08-00	Cylinder	1
18	GB/T 5783-2000	Bolt M8×20	8
19	GB/T 93-1987	Lock Washer 8 mm	20
20	GB/T 95-2000	Washer 8 mm	20
21	PMJ22J-03	Cylinder Mounting Plate	2
22	PMJ22J-15	Pin	1
23	PMJ22G-30	R-Pin	2
24	PMJ22G-15	Hydraulic Hose (Valve-Oil Tank)	1
25	PMJ22J-09-00	Pin	2
26	PMJ22J-06	Base Tube	1
27	PMJ22J-01-00	Base Connector	1
28	PMJ22J-10	Pin	1
29	PMJ22G-40	2" Coupler	1
30	GB/T 5782-2000	Bolt M12×80	2
31	PMJ22J-07-00	Front Support Leg	1
32	PMJ22G-41	Safety Chain With Hook	2
33	GB/T 97.2-1985	Washer 12	4
34	GB/T 5782-2000	Bolt M12×90	1
35	GB/T 5782-2000	Bolt M12×65	2
36	PMJ22J-18	Hydraulic Hose (Valve-Pump)	1
37	GB/T 3452.1-92	"O" Ring 10×2.65	1
38	PMJ22G-21	Outlet Connector Of Pump	1
39	PMJ22J-14	Gear Pump	1
40	JB/T 8870 1999	Clamp D40	2
41	PMJ22G-17	Oil Hose	1
42	GB/T 5783-2000	Bolt M8×30	4

#	Part number	Description	Qty
43	GB/T 6170-2000	Nut M8	9
44	GB/T 77-2000	Screw M6×10	1
45	PMJ22G-26	Gear Pump Connector	1
46	ASME B18.2.1 1996	Bolt 5/16"-24×1"	4
47	PMJ22G-29	Engine Bushing	1
48	PMJ22G-48	Engine	1
49	GB/T 1096-1979	Flat Key	1
50	PMJ22G-28	Engine Connector	1
51	PMJ22G-27	Gear Pump Stand	1
52	PMJ22G-32	Connector Cover	1
53	GB/T 845C-1985	Tapping Screw	4
54	GB/T 848-1985	Lock Washer 4 mm	4
55	GB/T 859-1987	Washer 4 mm	4
56	GB/T 1096-1979	Flat Key	1
57	GB/T 70.1-2000	Screw M5×20	6
58	GB/T 93-1987	Lock Washer 5 mm	6
59	GB/T 95-1985	Washer 5 mm	6
60	PMJ22G-07-00	Filter Fix Plate	1
61	PMJ22G-44	Filter	1
62	PMJ22G-19	Oil Plug	1
63	GB/T 3452.1-92	"O" Ring 80×3.55	1
64	GB/T 5782-2000	Bolt M8×45	4
65	PMJ22G-52	Auto Filter	1
66	PMJ22G-50	Auto Filter Base	1
67	PMJ22G-18	Screw NPT 1"	1
68	GJY12-3	R-Pin	1
69	GB/T 5782-2000	Bolt M12×85	2
70	PMJ22G-12	Hinge Pin	1
71	PMJ22J-11-00	Oil Tank	1
72	GB/T 91-2000	Cotter Pin 4×32	2
73	PMJ22J-05-01	Cased Seal	2
74	L44634 LYC DS	Tapered Bearing	4
75	PMJ22J-05-03	Wheel	2
76	GB/T 9459-1988	Slotted Nut M20×1.5	2
77	PMJ22J-05-02	Axle Cap	2
78	PMJ22J-19	Plate	1
79	GB/T 859-1987	Washer 8 mm	2
80	GB/T 70.2-2000	Bolt M8×12	2
81	PMJ22G-38	Big Tension Spring	1
82	GB/T 798-1988	Swing Bolt M8×28	1
83	GB 1160.2-89	Oil scale	1

SPECIFICATIONS

Engine Parts Diagram

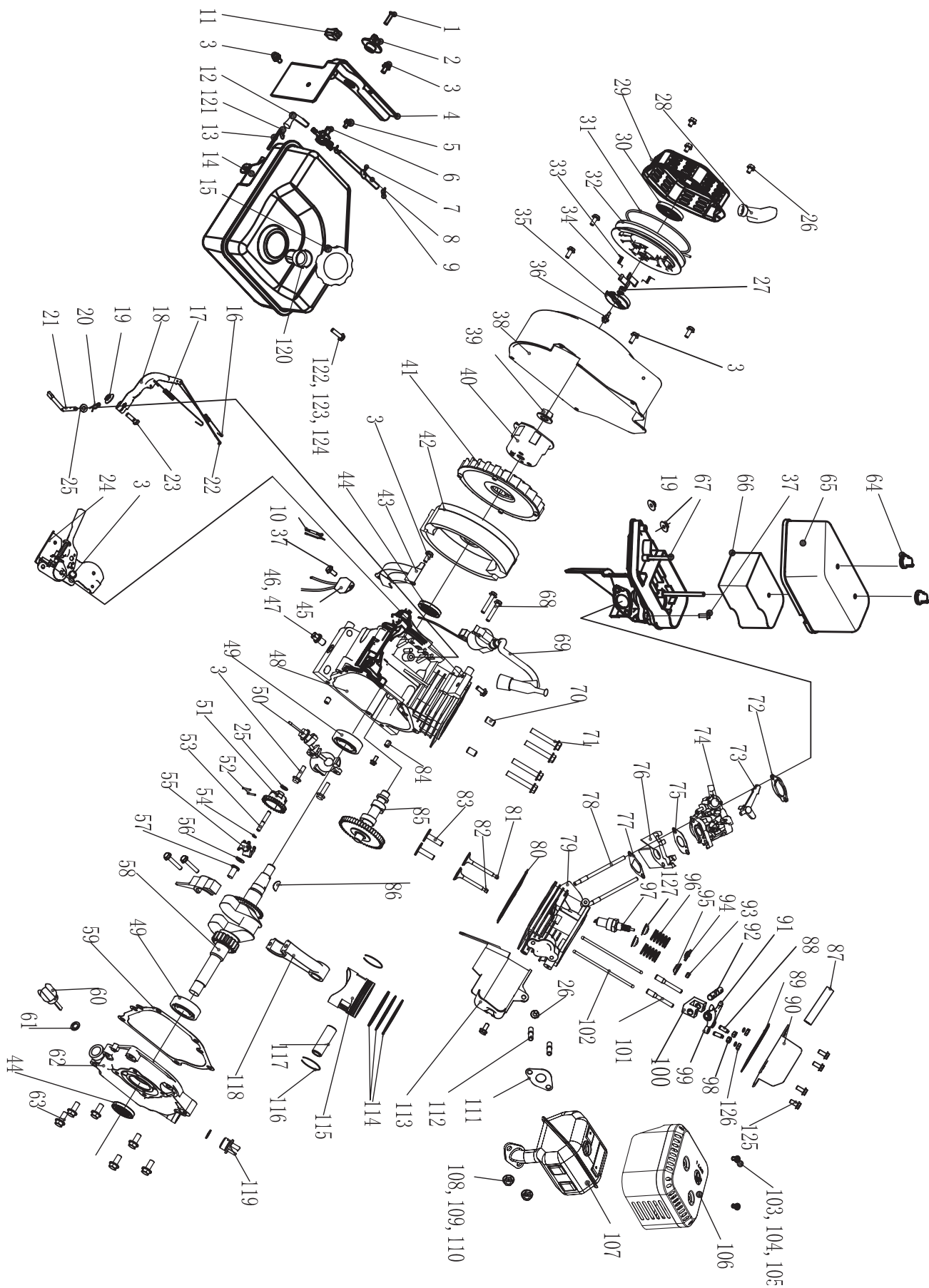

#	Part Number	Description	Qty
1	GB818-88-B4-12	Bolt M4x12	1
2	ST168F-1070003-G	Fuel Valve Knob	1
3	GB16674-1-FB6-12	Flange Bolt M6*12	11
4	168.070010.34	Fuel Tank Veil	1
5	GB5787--86-FB5-12	Flange Bolt M5*12	1
6	ST168F-1070200-G	Fuel Valve	1
7	ST168F-1070008-G	Tube Clip 9.5	1
8	ST168F-1070004-G	Tube 1	1
9	ST188FD--1070006A	Clip 8	3
10	168.120700.00	Wire Flame Out	1
11	21.001000.00	Switch	1
12	ST168F-1070005-G	Tube 2	1
13	ST152FD-1070200	Fuel Filter	1
14	168.071000.32	Fuel Tank Comp	1
15	ST160F--1070100H	Fuel Tank Cap Comp	1
16	ST168F--1110005	Throttle Return Spring	1
17	ST168F--1110007	Governor Spring	1
18	ST160F--1110003	Governor Arm	1
19	GB6177--86-N6	Nut M6	3
20	ST160F--1110008	Lock Pin	1
21	ST160F--1110001	Governor Arm Shaft	1
22	ST168F--1110006	Governor Rod	1
23	ST160F--1110004	Governor Arm Bolt	1
24	ST168F--1111000	Control Assembly	1
25	ST160F--1110108	Governor Washer	2
26	GB5789--86-FB6-8	Flange Bolt M6*8	5
27	ST188F-1060004	Ratchet Guide Spring	1
28	ST160F--1061200	Recoil Starter Knob	1
29	ST160F--1061100-Q	Recoil Starter Cover	1
30	ST160F--1061005	Recoil Starter Spring	1
31	ST160F--1061009	Recoil Starter Rope	1
32	ST160F--1061001-A	Recoil Starter Reel	1
33	ST188F-1060006	Ratchet Spring	2
34	ST188F-1060005	Starter RatchetMetal	2
35	ST188F-1060003	Ratchet Guide	1
36	ST188F-1060002	Setting Screw	1
37	GB5789--86-FB6-20	Flange Bolt M6*20	4
38	ST168F--1080100-G	Fan Cover Comp	1
39	ST160F--1050010	Nut M14	1
40	ST160F--1060001	Start Hub	1
41	ST168F--1080001	Cooling Fan	1
42	ST168F--1120100	Fly Wheel	1
43	ST168F--1080200	Side Place	1
44	ST168F--1030100	Oil Seal	2
45	ST160F-1126000	Diode Comp	1
46	ST160F--1030003	Drain Plug Bolt	2
47	ST160F--1030004	Drain Bolt Washer	2
48	ST168F-2-1030012-G	CrankcaseFor USA	1
49	GB/T-276-94	Radial Ball Bearing 6205	2
50	ST160F-1127000-A	Oil Level Switch Assy	1
51	ST160F--1110101	Governor Weight Holder	1
52	ST160F--1110102	Governor Weight Pin	2
53	ST160F--1110104	Governor Shaft	1
54	ST160F--1110103	Governor Holder Clip	1
55	ST160F--1110107	Governor Weight	2
56	ST168F-1040014	Valve Oil Seal	2
57	ST160F--1110105-A	Governor Cover	1
58	ST168F-2-1050001-Q	Crankshaft Comp	1
59	ST168F--1030008-G	Case Over PackingNo Asbestos)	1
60	ST160F--1030001-B	Oil Filler Cap Assembly	1
61	ST160F--1030002	Oil Filler Cap Packing	2
62	ST168F-1030007-5/16-G	Crankcase CoverFor USA	1
63	GB5789--86-FB8-32	Flange Bolt 8*32	6
64	ST168F-1090100	Air Cleaner Cover Nut(Plastic)	2

#	Part Number	Description	Qty
65	168.091200.38	Air Cleaner Cover	1
66	168.091003.38	Air Cleaner Element	1
67	ST168F-1090500-GC	Air Cleaner Elbow Comp	1
68	GB5789--86-FB6-25	Flange Bolt 6*25	2
69	ST160F-1123000-G	Ignition	1
70	152FMD--1001007	Dowel Pin 10*16	2
71	GB5789--86-FB8-55	Flange Bolt 8*55	4
72	ST160F--1130004	Carburetor Washer	1
73	ST160F--1130100	Choke Level Comp	1
74	ST168F-2-1130000-G	Carburetor Assembly	1
75	ST160F--1130003-CPE	Carburetor PackingNo Asbestos)	1
76	ST168F--1130001	Carburetor Insulator	1
77	ST168F--1130002-CPE	Insulator PackingNo Asbestos)	1
78	ST160F--1010001	Stud Bolt 6*110	2
79	ST168F-2-1010100-G	Cylinder Head Comp	1
80	ST168F-2-1030009-G	Cylinder Head Gasket	1
81	ST168F--1040002	Intake Valve	1
82	ST168F--1040006	Exhaust Valve	1
83	ST168F-2-1040013	Valve Lifter	2
84	ST168F-1030015-G	Dowel Pin 9*14	2
85	ST168F-2-1041000	Camshaft Assembly	1
86	4X7.5X19-GB1099-79	Key	1
87	ST160F--1020001	Breather Tube	1
88	ST168F--1040024	Rectify Bolt	2
89	ST160F--1020002-A	Head Over Packing	1
90	ST168F--1020100-C	Head Over Comp	1
91	ST168F--1040022	Entrance Rocker	1
92	ST168F--1040021	Rocker Axes	1
93	ST160F--1040008	Valve Rotator	1
94	ST160F--1040001	Intake Valve Spring Retainer	1
95	ST160F--1040007	Exhaust Valve Spring Retainer	1
96	ST160F--1040003	Valve Spring	2
97	F6RTC	Spark Plug	1
98	ST168F--1040025	Locknut	2
99	ST168F--1040023	Exhaust Rocker	1
100	ST168F--1040026	Valve Rocker Arm	1
101	ST168F--1040027	Pivot Bolt	2
102	ST168F--1040005	Push Rod	2
103	GB16674.1-FB5-8	Flange Bolt M5*8	4
104	GB848-85-W5	Washer 5	4
105	GB859-87-SW5	Spring Washer 5	4
106	ST160F--1101100-G	Muffler Protector(Black)	1
107	ST160F--1101200-G	Muffler Comp	1
108	GB6170--86-N8	Nut M8	2
109	GB848-85-W8	Washer 8	2
110	GB859-87-SW8	Spring Washer 8	2
111	ST168F-1100200-G	Muffler PackingNo Asbestos)	1
112	ST160F-1010002	Stud Bolt	2
113	ST168F--1080002-G	Shroud Comp	1
114	ST168F-1050007	First Ring Set	1
	ST168F-1050006	Second Ring Set	1
	ST168F-1050200	Oil Ring Comp	1
115	ST168F-II-1050005	Piston	1
116	ST168F--1050004	Piston Pin Clip	2
117	ST168F--1050003	Piston Pin	1
118	ST168F--1050100	Connecting Rod Comp	1
119	ST160F--1030005-B	Oil Filler Cap	1
120	ST160F-1070006	Fuel Filter	1
121	ST1P68F-1070006-F	Clip	1
122	GB848-85-W6	Washer 6	6
123	GB859-87-SW6	Spring Washer 6	4
124	GB5789--86-FB6-35	Flange Bolt M6*35	1
125	GB5789--86-FB6-15	Flange Bolt M6*15	4
126	GB6187-86-N6	Nut M6	2

TROUBLESHOOTING

Problem	Cause	Solution
Engine will not start	No fuel	Add fuel
	Faulty spark plug	Replace spark plug
	Unit loaded during start up	Remove load from unit
Engine will not start; Engine starts but runs roughly	Low oil level	Fill crankcase to the proper level Place log splitter on a flat, level surface
	Choke in the wrong position.	Adjust choke
	Spark plug wire loose	Attach wire to spark plug
Engine shuts down during operation	Out of fuel	Fill fuel tank
	Low oil level	Fill crankcase to the proper level. Place log splitter on a flat, level surface
Engine cannot supply enough power or overheating	Insufficient ventilation	Check for air restriction. Move to a well ventilated area

For further technical support:

Technical Service

Mon – Fri 8:30 AM – 5:00 PM (PST/PDT)

Toll Free: 1-877-338-0999

tech@championpowerequipment.com

WARRANTY

CHAMPION POWER EQUIPMENT
1 YEAR LIMITED WARRANTY

Warranty Qualifications

Champion Power Equipment (CPE) will register this warranty upon receipt of your Warranty Registration Card and a copy of your sales receipt from one of CPE's retail locations as proof of purchase.

Please submit your warranty registration and your proof of purchase within ten (10) days of the date of purchase.

Repair/Replacement Warranty

CPE warrants to the original purchaser that the mechanical and electrical components will be free of defects in material and workmanship for a period of one (1) year from the original date of purchase (90 days for commercial & industrial use). Transportation charges on product submitted for repair or replacement under this warranty are the sole responsibility of the purchaser.

This warranty only applies to the original purchaser and is not transferable.

Do Not Return The Unit To The Place Of Purchase

Contact CPE's Technical Service and CPE will troubleshoot any issue via phone or e-mail. If the problem is not corrected by this method, CPE will, at its option, authorize evaluation, repair or replacement of the defective part or component at a CPE Service Center. CPE will provide you with a case number for warranty service. Please keep it for future reference. Repairs or replacements without prior authorization, or at an unauthorized repair facility, will not be covered by this warranty.

Warranty Exclusions

This warranty does not cover the following repairs and equipment:

Normal Wear

Log Splitter needs periodic parts and service to perform well. This warranty does not cover repair when normal use has exhausted the life of a part or the equipment as a whole.

Installation, Use and Maintenance

This warranty will not apply to parts and/or labor if this log splitter is deemed to have been misused, neglected, involved in an accident, abused, loaded beyond its limits, modified, and installed improperly. Normal maintenance such as spark plugs, air filters, adjustments, fuel system cleaning and obstruction due to buildup is not covered by this warranty.

Other Exclusions

This warranty excludes:

- Cosmetic defects such as paint, decals, etc.
- Wear items such as filter elements, o-rings, etc.
- Accessory parts such as starting batteries, and storage covers.
- Failures to due acts of God and other force majeure events beyond the manufacturer's control.
- Problems caused by parts that are not original Champion Power Equipment parts.

Limits of Implied Warranty and Consequential Damage

Champion Power Equipment disclaims any obligation to cover any loss of time, use of this product, freight, or any incidental or consequential claim by anyone from using this log splitter. THIS WARRANTY IS IN LIEU OF ALL OTHER WARRANTIES, EXPRESS OR IMPLIED, INCLUDING WARRANTIES OF MERCHANTABILITY OR FITNESS FOR A PARTICULAR PURPOSE.

A unit provided as an exchange will be subject to the warranty of the original unit. The length of the warranty governing the exchanged unit will remain calculated by reference to the purchase date of the original unit.

This warranty gives you certain legal rights which may change from state to state. Your state may also have other rights you may be entitled to that are not listed within this warranty.

Contact Information**Address**

Champion Power Equipment, Inc.
Customer Service
10006 Santa Fe Springs Rd.
Santa Fe Springs, CA 90670
www.championpowerequipment.com

Customer Service

Mon – Fri 8:30 AM – 5:00 PM (PST/PDT)
Toll Free: 1-877-338-0999
Fax no.: 1-562-236-9429

Technical Service

Mon – Fri 8:30 AM – 5:00 PM (PST/PDT)
Toll Free: 1-877-338-0999
tech@championpowerequipment.com

WARRANTY

**Champion Power Equipment, Inc (CPE),
and the United States Environment Protection Agency (U.S. EPA.)
Emission Control System Warranty**

Your Champion Power Equipment (CPE) engine complies with U.S. EPA emission regulations.

YOUR WARRANTY RIGHTS AND OBLIGATIONS:

The US EPA AND CPE are pleased to explain the Federal Emission Control Systems Warranty on your 2011 and later small off-road engine. New engines must be designed, built and equipped, at the time of sale, to meet U.S. EPA regulations for small non-road engines. CPE must warrant the emission control system on your small off-road engine for the period of time listed below, provided there has been no abuse, neglect, unapproved modification, or improper maintenance of your small off-road engine.

Your emission control system may include parts such as the carburetor, fuel-injection system, the ignition system, catalytic converter and fuel lines. Also included may be hoses, belts, connectors and other emission related assemblies. Where a warrantable condition exists, CPE will repair your small off-road engine at no cost to you including diagnosis, parts and labor.

MANUFACTURER'S EMISSION CONTROL SYSTEM WARRANTY COVERAGE:

This emission control system is warranted for two years, subject to provisions set forth below. If, during the warranty period, emission related part on your engine is defective in materials or workmanship, the part will be repaired or replaced by CPE.

OWNER WARRANTY RESPONSIBILITIES:

As the small off-road engine owner, you are responsible for the performance of the required maintenance listed in your Owner's Manual. CPE recommends that you retain all your receipts covering maintenance on your small off-road engine, but CPE cannot deny warranty solely for the lack of receipts or for your failure to ensure the performance of all scheduled maintenance.

As the small off-road engine owner, you should however be aware that CPE may deny you warranty coverage if your small, off-road engine or a part has failed due to abuse, neglect, improper maintenance or unapproved modifications.

You are responsible for presenting your small off-road engine to an Authorized CPE service outlet, CPE dealer or CPE, Santa Fe Springs, Ca. as soon as a problem exists. The warranty repairs should be completed in a reasonable amount of time, not to exceed 30 days.

If you have any questions regarding your warranty rights and responsibilities, you should contact:

Champion Power Equipment, Inc.

ATTN: Customer Service
10006 Santa Fe Springs Road
Santa Fe Springs, CA 90670
Tel: 1-877-338-0999

The emission warranty is a defects warranty. Defects are judged on normal engine performance. The warranty is not related to an in-use emission test.

EMISSION CONTROL SYSTEM WARRANTY

The following are specific provisions relative to your Emission Control System Warranty Coverage.

Emission Control System Warranty (ECS Warranty) for 1997 and later model year engines):

- 1. APPLICABILITY:** This warranty shall apply to 1997 and later model year engines). The ECS Warranty Period shall begin on the date the new engine or equipment is delivered to its original, end-use purchaser, and shall continue for 24 consecutive months thereafter.
- 2. GENERAL EMISSIONS WARRANTY COVERAGE**

CPE warrants to the original, end-use purchaser of the new engine or equipment and to each subsequent purchaser that each of its small off-road engines is:

 - a. Designed, built and equipped so as to conform at the time of sale with applicable regulations under section 213 of the Clean Air Act, as amended, 42 U.S.C. 7401 et seq.
 - b. Free from defects in materials and workmanship that cause the failure of a warranted part to be identical in all material respects to the part as described in the engine manufacturer's application for certification for a period of two years.
- 3. THE WARRANTY ON EMISSION-RELATED PARTS WILL BE INTERPRETED AS FOLLOWS:**
 - a. Any warranted part that is not scheduled for replacement as required maintenance in the Owners Manual shall be warranted for the ECS Warranty Period. If any such part fails during the ECS Warranty Period, it shall be repaired or replaced by CPE according to Subsection "d" below. Any such part repaired or replaced under the ECS Warranty shall be warranted for any remainder of the ECS Warranty Period.
 - b. Any warranted, emissions-related part which is scheduled only for regular inspection as specified in the Owners Manual shall be warranted for the ECS Warranty Period. A statement in such written instructions to the effect of "repair or replace as necessary", shall not reduce the ECS Warranty Period. Any such part repaired or replaced under the ECS Warranty shall be warranted for the remainder of the ECS Warranty Period.
 - c. Any warranted, emissions-related part which is scheduled for replacement as required maintenance in the Owner's Manual shall be warranted for the period of time prior to the first scheduled replacement point for that part. If the part fails prior to the first scheduled replacement, the part shall be repaired or replaced by CPE according to Subsection "d" below. Any such emissions-related part repaired or replaced under the ECS Warranty, shall be warranted for the remainder of the ECS Warranty Period prior to the first scheduled replacement point for such emissions-related part.
 - d. Repair or replacement of any warranted, emissions-related part under this ECS Warranty shall be performed at no charge to the owner at a CPE Authorized Service Outlet.
 - e. The owner shall not be charged for diagnostic labor which leads to the determination that a part covered by the ECS Warranty is in fact defective, provided that such diagnostic work is performed at a CPE Authorized Service Outlet.
 - f. CPE shall be liable for damages to other original engine components or approved modifications proximately caused by a failure under warranty of an emission-related part covered by the ECS Warranty.
 - g. Throughout the ECS Warranty Period, CPE shall maintain a supply of warranted emission-related parts sufficient to meet the expected demand for such emission-related parts.
 - h. Any CPE Authorized and approved emission-related replacement part may be used in the performance of any ECS Warranty maintenance or repair and will be provided without charge to the owner. Such use shall not reduce CPE's warranty obligation.
 - i. Unapproved add-on or modified parts may not be used to modify or repair a CPE engine. Such use voids this ECS Warranty and shall be sufficient grounds for disallowing an ECS Warranty claim. CPE shall not be liable hereunder for failures of any warranted parts of a CPE engine caused by the use of such an unapproved add-on or modified part.

WARRANTY

EMISSION-RELATED PARTS INCLUDE THE FOLLOWING (using those portions of the list applicable to the engine):

Systems covered by this warranty	Parts Description
Fuel Metering System	Fuel regulator, Carburetor and internal parts
Air Induction System	Air cleaner, Intake manifold
Ignition System	Spark plug and parts, Magneto ignition system
Exhaust System	Exhaust manifold, catalytic converter
Miscellaneous Parts	Tubing, Fittings, Seals, Gaskets, and Clamps associated with these listed systems

TO OBTAIN WARRANTY SERVICE:

You must take your CPE engine or the product on which it is installed, along with your warranty registration card or other proof of original purchase date, at your expense, to any Champion Power Equipment dealer who is authorized by Champion Power Equipment, Inc. to sell and service that CPE product during his normal business hours. Claims for repair or adjustment found to be caused solely by defects in material or workmanship will not be denied because the engine was not properly maintained and used.

If you have any questions regarding your warranty rights and responsibilities, or to obtain warranty service, please write or call the Customer service of Champion Power Equipment, Inc.:

Champion Power Equipment, Inc.

ATTN: Customer Service

10006 Santa Fe Springs Road

Santa Fe Springs, CA 90670

Tel: 1-877-338-0999