

# CHAMPION

POWER EQUIPMENT™

OWNER'S MANUAL & OPERATING INSTRUCTIONS



## 3000 PSI / 2.5 GPM Wireless Remote Electric Start **PRESSURE WASHER**



MODEL NUMBER  
**76554**

**SAVE THESE INSTRUCTIONS**  
Important Safety Instructions  
are included in this manual.

MADE IN CHINA  
REV 76554-20120427

10006 Santa Fe Springs Road  
Santa Fe Springs CA 90670  
USA / 1-877-338-0999  
[www.championpowerequipment.com](http://www.championpowerequipment.com)

**Have questions or need assistance?**

Do not return this product to the store!

**WE ARE HERE TO HELP!**

Visit our website:

**[www.championpowerequipment.com](http://www.championpowerequipment.com)**

for more info:

- Product Info & Updates
- Tech Bulletins
- Frequently Asked Questions
- Product Registration

– or –

Call our Customer Care Team Toll-Free at:

**1-877-338-0999**

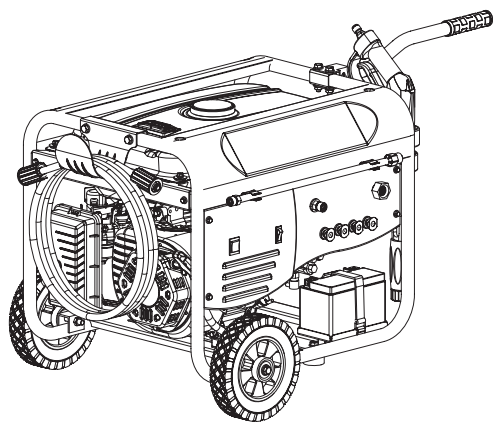

# 3000 PSI / 2.5 GPM Wireless Remote Electric Start PRESSURE WASHER

## TABLE OF CONTENTS

<b>Introduction</b>	<b>1</b>	Oil	15
Pressure Washer	1	Spark Plugs	15
Accessories	1	Air Filter	16
This Booklet	1	Cleaning	16
<b>Manual Conventions</b>	<b>2</b>	Adjustments	16
<b>Safety Rules</b>	<b>3</b>	Maintenance Schedule	16
<b>Controls and Features</b>	<b>5</b>	Pressure Washer Maintenance	16
Pressure Washer	5	Cleaning Spray Nozzle	16
Utility Panel	6	<b>Storage</b>	<b>17</b>
Wireless Remote Control	7	Engine Storage	17
Parts Included	8	Pressure Washer Storage	17
<b>Assembly</b>	<b>9</b>	Disconnecting the Battery	17
Remove the Pressure Washer from the		Charging the Battery	17
Shipping Carton	9	Winter Storage	17
Install the Wheel Kit	9	<b>Specifications</b>	<b>18</b>
Install the Support Leg	9	Engine Specifications	18
Install the Handle	9	Pressure Washer Specifications	18
Connect the Battery	9	Fuel	18
Attach the Hose Hanger	10	Oil	18
Attach the Wand Holder	10	Spark Plugs	18
Attach the Gun Holder	10	Maintenance Valve Clearance	18
Install the Hoses	10	IC Warning	18
Attach the Pressure Gun	10	Pressure Washer Parts Diagram	19
Connect to Garden Hose	10	Pressure Washer Parts List	20
Attach the Detergent Hose	10	Engine Parts Diagram	21
Add Engine Oil	11	Engine Parts List	22
Add Fuel	11	<b>Troubleshooting</b>	<b>23</b>
<b>Operation</b>	<b>12</b>	<b>Warranty</b>	<b>24</b>
Pressure Washer Location	12	Warranty Qualifications	24
Before Starting the Engine	12	Repair/Replacement Warranty	24
Wireless Remote Start	12	Do not return the unit to the place of	
Starting the Engine Without the Remote	12	purchase	24
Distance from Cleaning Surface	13	Warranty Exclusions	24
High Pressure Wash	13	Normal Wear	24
Low Pressure Wash	13	Installation, Use and Maintenance	24
Detergent Use	13	Other Exclusions	24
System Flush	13	Limits of Implied Warranty and	
Depressurize System	14	Consequential Damage	24
Operating Tips	14	Contact Information	24
Stopping the Engine	14	Address	24
<b>Maintenance</b>	<b>15</b>	Customer Service	24
Engine Maintenance	15	Technical Service	24

# INTRODUCTION

## Introduction

Congratulations on your purchase of a Champion Power Equipment pressure washer. CPE designs and builds pressure washers to strict specifications. With proper use and maintenance, this pressure washer will bring years of satisfying service.

## Pressure Washer

This unit is a gasoline engine driven pressure washer. It is designed for use in cleaning with or without detergent and is suitable for decks, patios, house siding, vehicles, lawn furniture, barbecue grills, gardening tools and more.

## Accessories

Champion Power Equipment manufactures and sells accessories designed to help you get the most from your purchase. To find out more about our accessories, please visit our website at:

→ [www.championpowerequipment.com](http://www.championpowerequipment.com)

## This Booklet

Every effort has been made to ensure the accuracy and completeness of the information in this manual. We reserve the right to change, alter and/or improve the product and this document at any time without prior notice.

Record the model and serial numbers as well as date and place of purchase for future reference. Have this information available when ordering parts and when making technical or warranty inquiries.

<b>Champion Power Equipment Support</b>
<b>1-877-338-0999</b>
Model Number
<b>76554</b>
Serial Number
Date of Purchase
Purchase Location
For <b>Oil Type</b> see 'Add Engine Oil' section. For <b>Fuel Type</b> see 'Add Fuel' section.

This manual uses the following symbols to help differentiate between different kinds of information. The safety symbol is used with a key word to alert you to potential hazards in operating and owning power equipment.

Follow all safety messages to avoid or reduce the risk of serious injury or death.

 **DANGER**

DANGER indicates an imminently hazardous situation which, if not avoided, **will** result in death or serious injury.

 **WARNING**

WARNING indicates a potentially hazardous situation which, if not avoided, **could** result in death or serious injury.

 **CAUTION**

CAUTION indicates a potentially hazardous situation which, if not avoided, **may** result in minor or moderate injury.

**CAUTION**

CAUTION used without the safety alert symbol indicates a potentially hazardous situation which, if not avoided, **may** result in property damage.

 **NOTE**

If you have questions regarding your pressure washer, we can help. Please call our help line at **1-877-338-0999**

# SAFETY RULES

## WARNING

Read this manual thoroughly before operating your pressure washer. Failure to follow instructions could result in serious injury or death.

## WARNING

The engine exhaust from this product contains chemicals known to the state of California to cause cancer, birth defects, or other reproductive harm.

## DANGER

Engine exhaust contains carbon monoxide, a colourless, odourless, poison gas. Breathing carbon monoxide will cause nausea, dizziness, fainting or death. If you start to feel dizzy or weak, get to fresh air immediately.

Operate pressure washer outdoors only in a well ventilated area.

DO NOT operate the pressure washer inside any building, including garages, basements, crawlspaces and sheds, enclosure or compartment, including the pressure washer compartment of a recreational vehicle.

DO NOT allow exhaust fumes to enter a confined area through windows, doors, vents or other openings.

**DANGER CARBON MONOXIDE**, using a pressure washer indoors **CAN KILL YOU IN MINUTES**.

## DANGER

Rotating parts can entangle hands, feet, hair, clothing and/or accessories.  
Traumatic amputation or severe laceration can result.

Keep hands and feet away from rotating parts.  
Tie up long hair and remove jewelry.  
Operate equipment with guards in place.  
DO NOT wear loose-fitting clothing, dangling drawstrings or items that could become caught.

## WARNING

Sparks can result in fire or electrical shock.

### When servicing the pressure washer:

Disconnect the spark plug wire and place it where it cannot contact the plug.

DO NOT check for spark with the plug removed.

Use only approved spark plug testers.

## WARNING

Running engines produce heat. Severe burns can occur on contact. Combustible material can catch fire on contact.

DO NOT touch hot surfaces.

Avoid contact with hot exhaust gases.

Allow equipment to cool before touching.

Maintain at least three feet of clearance on all sides to ensure adequate cooling.

Maintain at least five feet of clearance from combustible materials.

## WARNING

DO NOT let water in the pump freeze.

See Storage section in the manual for instructions regarding winter storage.

If water has frozen in the pressure washer, thaw the pressure washer in a warm room before starting.

DO NOT pour hot water on or into the pump; internal parts will be damaged and your warranty will be voided.

## WARNING

NEVER spray flammable liquids or use pressure washer in areas containing combustible dust, liquids, or vapour.

NEVER operate this machine in a closed building or in or near an explosive environment.

- DO NOT remove fuel tank cap or fill fuel tank while engine is hot or running (allow engine to cool two minutes before refueling). Always fill the tank slowly.
- Never disconnect the high pressure discharge hose from the machine while the system is pressurized.

** DANGER**

Fuel and fuel vapours are highly flammable and extremely explosive.  
Fire or explosion can cause severe burns or death.  
Unintentional startup can result in entanglement, traumatic amputation or laceration.

**When adding or removing fuel:**

Turn the pressure washer off and let it cool for at least two minutes before removing the fuel cap.  
Loosen the cap slowly to relieve pressure in the tank.  
Only fill or drain fuel outdoors in a well-ventilated area.  
DO NOT pump gas directly into the pressure washer at the gas station. Use an approved container to transfer the fuel to the pressure washer.  
DO NOT overfill the fuel tank.  
Always keep fuel away from sparks, open flames, pilot lights, heat and other sources of ignition.  
DO NOT light or smoke cigarettes.

**When starting the pressure washer:**

DO NOT attempt to start a damaged pressure washer.  
Make certain that the gas cap, air filter, spark plug, fuel lines and exhaust system are properly in place.  
Allow spilled fuel to evaporate fully before attempting to start the engine.  
Make certain that the pressure washer is resting firmly on level ground.

**When operating the pressure washer:**

DO NOT move or tip the pressure washer during operation.  
DO NOT tip the pressure washer or allow fuel or oil to spill.

**When transporting or servicing the pressure washer:**

Make certain that the fuel shutoff valve is in the off position and the fuel tank is empty.  
Disconnect the spark plug wire.  
When storing the pressure washer:  
Store away from sparks, open flames, pilot lights, heat and other sources of ignition.

**CAUTION**

**NEVER** run the unit dry.

Be sure the water supply is completely turned on before operating the unit.

** WARNING**

Rapid retraction of the starter cord will pull hand and arm towards the engine faster than you can let go.  
Unintentional startup can result in entanglement, traumatic amputation or laceration.  
Broken bones, fractures, bruises or sprains could result.

When starting engine, pull the starter cord slowly until resistance is felt and then pull rapidly to avoid kickback.

** DANGER**

Keep clear of nozzle.  
DO NOT point the pressure wand at a person, an animal or yourself.

Always wear safety glasses or goggles and protective equipment (hearing protection, gloves, rubber boots, protective clothing) when operating or performing maintenance.

- Never put hand or fingers over the spray tip while operating the unit.
- Never try to stop or deflect leaks with any body part.
- Always engage the trigger safety latch in the safe position when spraying is stopped even if only for a few moments.

** CAUTION**

Improper treatment or use of the pressure washer can damage it, shorten its life and void your warranty.

Use the pressure washer only for intended uses.  
Operate only on level surfaces.  
DO NOT expose pressure washer to excessive moisture, dust, or dirt.  
DO NOT allow any material to block the cooling slots.  
DO NOT use the pressure washer if:

- Equipment sparks, smokes or emits flames
- Equipment vibrates excessively

** WARNING**

This product contains a button battery. If swallowed, it could cause severe injury or death in just 2 hours. Seek medical attention immediately.

# CONTROLS AND FEATURES

Read this owner's manual before operating your pressure washer. Familiarize yourself with the location and function of the controls and features. Save this manual for future reference.

## Pressure Washer

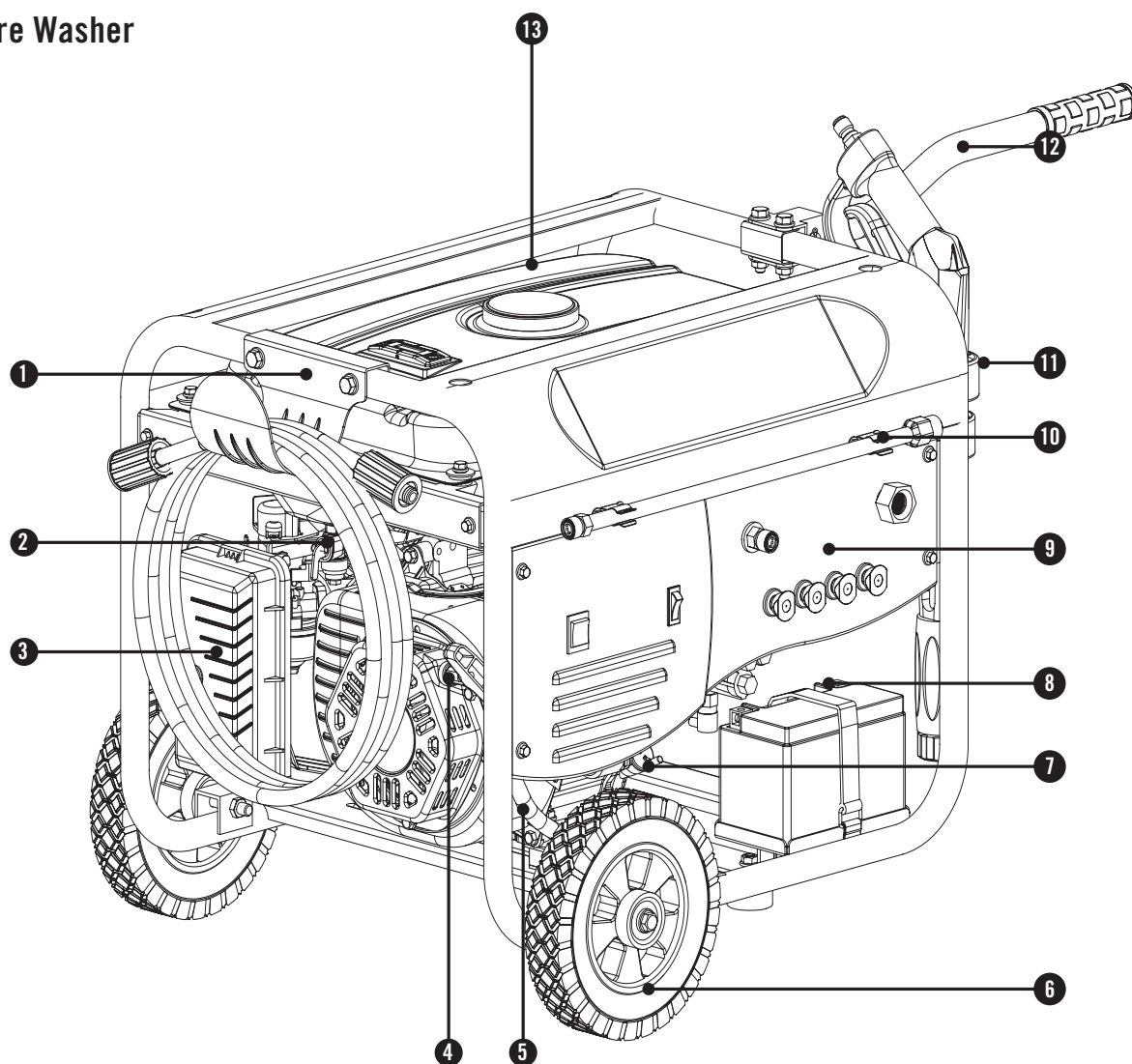

- |  |   |
|--|---|
| <p>(1) <b>High Pressure Hose Hanger</b> – Used to hold the high pressure hose when not in use.</p> <p>(2) <b>Fuel Valve Knob</b></p> <p>(3) <b>Air Filter</b> – Protects the engine by filtering dust and debris from the intake air.</p> <p>(4) <b>Recoil Starter</b> – Used to start the engine.</p> <p>(5) <b>Quick Drain Oil Draining System</b>– Used to quickly drain the engine oil.</p> <p>(6) <b>8 in. (20.32 cm) Never Flat Wheels</b></p> | <p>(7) <b>Oil Filler Cap</b> – Check and fill engine oil level.</p> <p>(8) <b>Battery</b></p> <p>(9) <b>Utility Panel</b> – See Utility Panel section.</p> <p>(10) <b>Wand Holder</b> – Used to hold the wand when not assembled and in use.</p> <p>(11) <b>Gun Holder</b> – Used to hold the gun when not assembled and in use.</p> <p>(12) <b>Handle</b></p> <p>(13) <b>Fuel Tank</b> – 4 gal. (15.1 L)</p> |
|--|---|



## Utility Panel

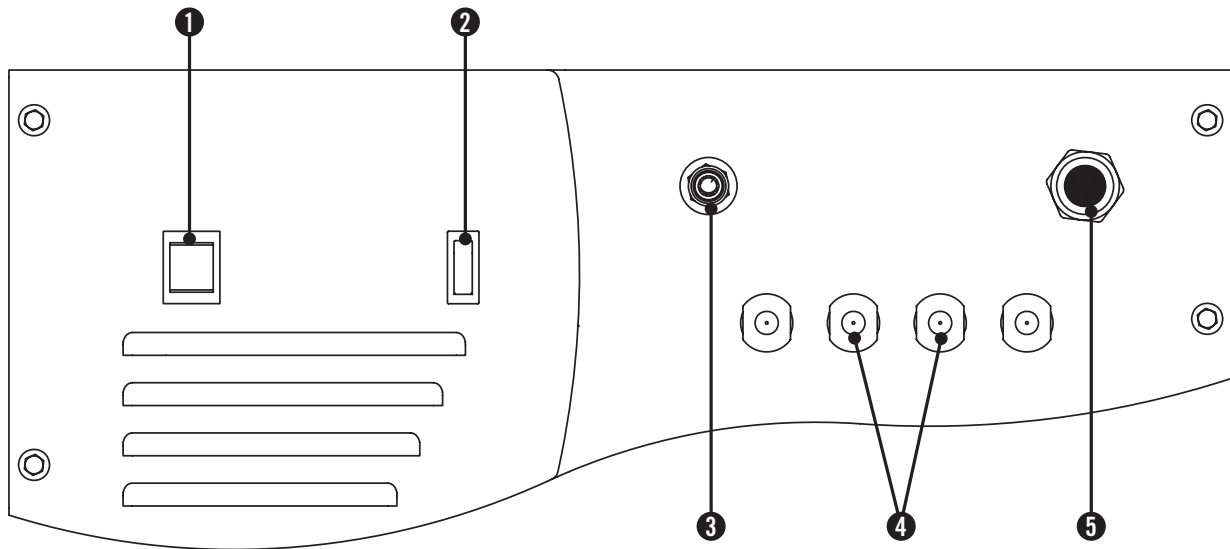

- (1) **Ignition Switch** – Used to start or stop the pressure washer.
- (2) **Battery Switch** – Enables/disables starting electrically – via remotely or by Ignition Switch.
- (3) **Quick Connect Hose Output** – Used to easily connect and disconnect the high pressure hose.
- (4) **Quick Connect Nozzle Storage** – Used to store the quick connect nozzles when not in use.
- (5) **Garden Hose Input** – Used to connect the water supply to unit.

# CONTROLS AND FEATURES

---

## Wireless Remote Control

This pressure washer is equipped with a wireless remote control system for starting and stopping. The system consists of (4) main components:

1. Receiver Control Module (RCM)
2. Wireless Remote
3. Battery Switch
4. Ignition Switch

The Remote Control functions are enabled when:

1. The Ignition Switch is in the "ON" position, *AND*
2. The Battery Switch is in the "ON" position.

The Remote Control functions are disabled if either of the above conditions is not met.

To start the pressure washer by Remote Control, press the "START" button on the Remote one time. The engine will attempt to start (6) times. The RCM controls the Auto Choke during each attempt to start. If the pressure washer does not start, call Champion Customer Care team for assistance at 1-877-338-0999.

To stop the pressure washer by Remote Control, press the "STOP" button on the Remote one time.

## Remote Control Power Consumption

While the Ignition Switch is in the "ON": position, the RCM is active and waiting for a remote signal. This function requires electrical current from the battery. If the Ignition Switch is left in the "ON" position for extended periods (several weeks), the battery can be completely drained.

Moving the Ignition Switch to the "OFF" position disables the Remote functions, but the RCM still consumes approximately 2 mA from the battery.

To prevent battery drain, press the Battery Switch to the "OFF" position. This disconnects power to the RCM so there is no current draw on the battery.

## Parts Included

Your 76554 Gasoline Powered Pressure Washer ships with the following parts:

### Wheel Kit

- 8" Wheel . . . . . 2
- Flange Bolt (M10x105 for Wheel) . . . . . 2
- Bushing . . . . . 2
- Flat Washer 10 . . . . . 2
- Nut (M10) . . . . . 2
- Support Leg w/Vibration Mounts . . . . . 1
- Flange Bolt (M8x25 for Mounts) . . . . . 2
- Flange Bolt (M8x16 for Support Leg) . . . . . 2
- Handle . . . . . 1
- Flange Bolt (M8x45 for Handle) . . . . . 2
- Nut (M8) . . . . . 8

### Gun Assembly

- Pressure Gun . . . . . 1
- Wand . . . . . 1
- Wand Holder (Clamp) . . . . . 2
- Bolt (M5x12 for Clamps) . . . . . 4
- Gun Holder . . . . . 1
- Flange Bolt (M8x50 for Gun Holder) . . . . . 1

### Hoses

- 25 ft. (7.62 m) High Pressure Hose . . . . . 1
- Detergent Hose . . . . . 1
- Hose Hanger . . . . . 1
- Flange Bolt (M8x40 for Pothook) . . . . . 2

### Other

- Oil Funnel . . . . . 1
- Spark Plug Socket . . . . . 1
- Remote . . . . . 1

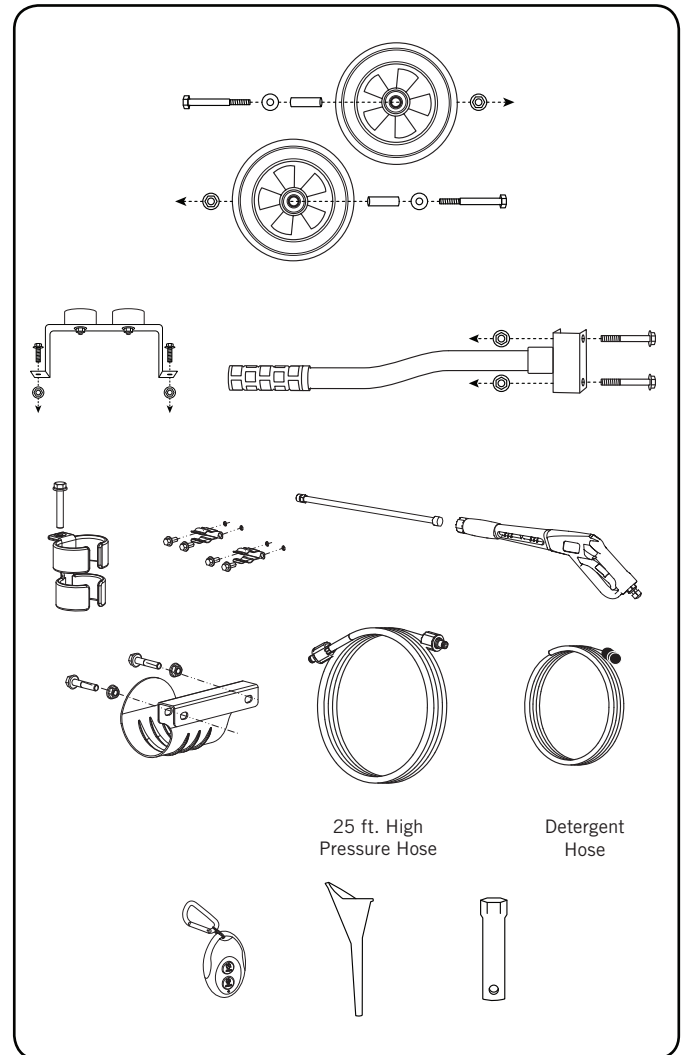

# ASSEMBLY

Your pressure washer requires some assembly. This unit ships from our factory without oil. It must be properly serviced with fuel and oil before operation.

If you have any questions regarding the assembly of your pressure washer, call our help line at 1-877-338-0999. Please have your serial number and model number available.

## Remove the Pressure Washer from the Shipping Carton

1. Set the shipping carton on a solid, flat surface.
2. Remove everything from the carton except the pressure washer.
3. Carefully cut each corner of the box from top to bottom.

## Install the Wheel Kit

### ! CAUTION

The wheel kit is not intended for over-the-road use.

You will need the following tools to install the wheels:

- 17 mm wrench OR adjustable wrench (not included)
- Socket wrench with a 16 mm socket (not included)
- Pliers (not included)

1. Before adding fuel and oil, tip the pressure washer on its side.
2. Slide the M10x105 wheel bolt through the washer, sleeve and wheel.
3. Slide the bolt through the mount point on the frame.
4. Fasten securely with the M10 nut.
5. Repeat steps 2-4 to attach the second wheel.

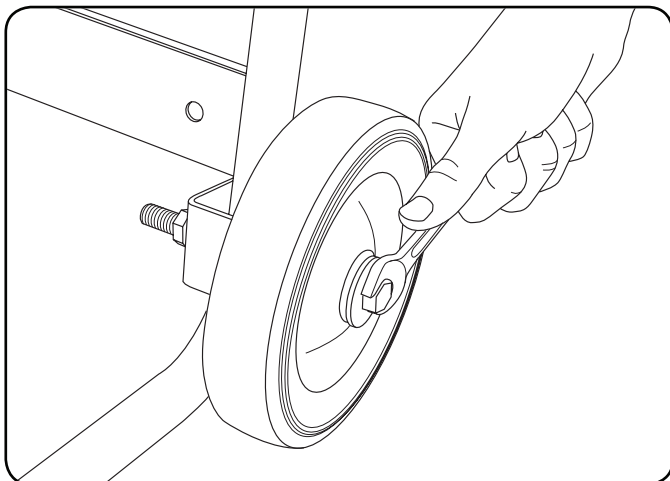

## Install the Support Leg

1. Attach the support leg to the pressure washer frame with cap screws (M8x16) and nuts (M8).
2. Tip the pressure washer slowly so that it rests on the wheels and support leg.

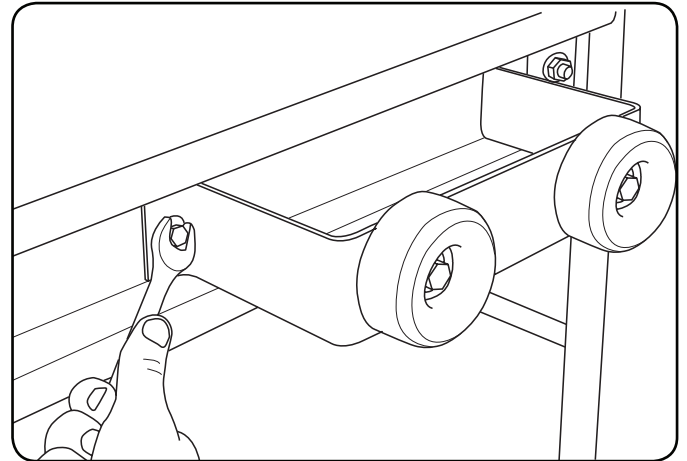

## Install the Handle

1. Place the handle over the mounting channel on the frame.
2. Secure the handle to the frame using the two handle bolts (M8x45).
3. Place a lock nut (M8) on the end of each bolt and fasten securely. DO NOT over tighten the lock nuts.

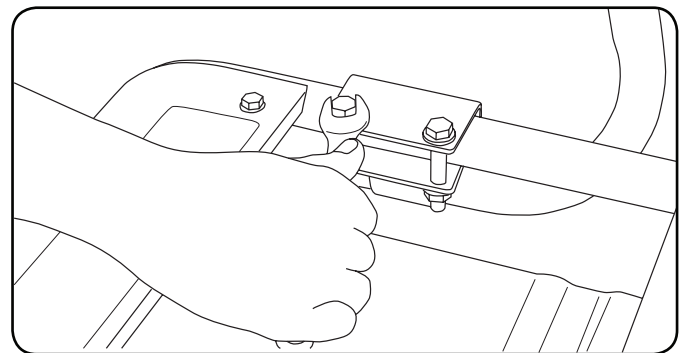

## Connect the Battery

1. Remove the protective cover from the red (+) lead on the battery.
2. Attach the red (+) lead to the red (+) terminal on the battery with the cap screw (M5x12) and secure with the lock washer (M5).
3. Repeat steps 1-2 for the black (-) battery lead.

### Attach the Hose Hanger

1. Slide Hose Hanger over the top of frame (recoil side).
2. Align Hose Hanger with mounting points on frame.
3. Slide the bolt (M8x40) through the mount point on the frame.
4. Fasten securely with the M8 nut.

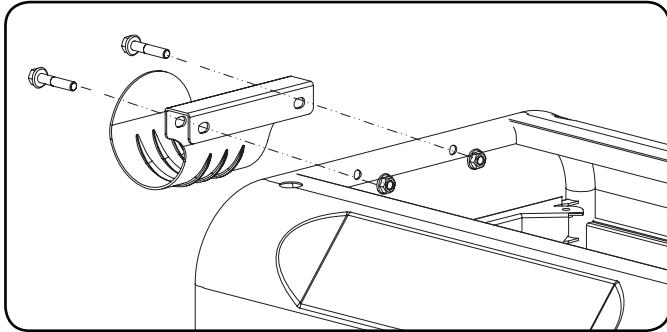

### Attach the Wand Holder (Clamps)

1. Align Clamp with mounting points on frame (power panel side).
2. Slide the bolt (M5x12) through the mount point on the frame.
3. Fasten securely.
4. Repeat steps 1-3 for second clamp.

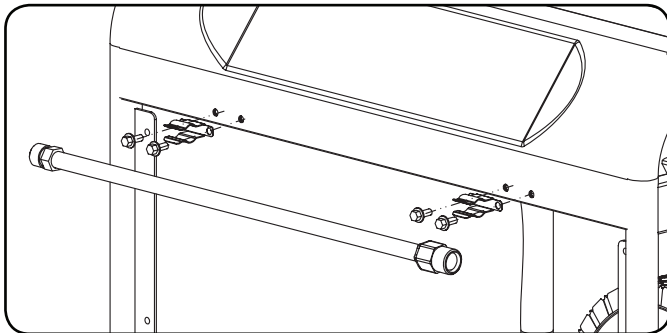

### Attach the Gun Holder

1. Align Gun Holder with mounting point on frame (Handle side).
2. Slide the bolt (M8x50) through the mount point on the frame.
3. Fasten securely.

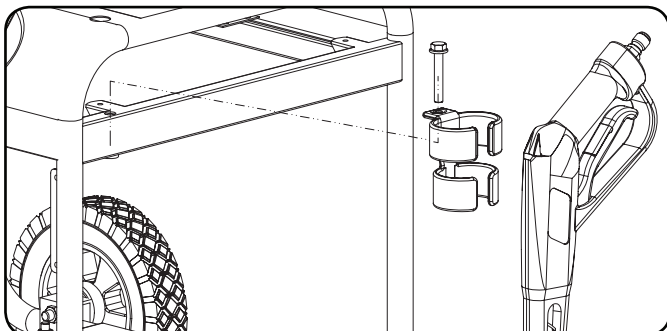

### Install the Hoses

#### Attach the Pressure Gun

1. Attach the wand with nozzle to the gun.
2. Connect the high pressure hose to the outlet connection on the pump.
3. Connect the other end of the high pressure hose to the gun.

#### Connect to Garden Hose

Secure a garden hose (not included) to the inlet connection on the pump.

#### Attach the Detergent Hose

Connect the clear detergent hose to the brass barb on the pumps outlet connector.

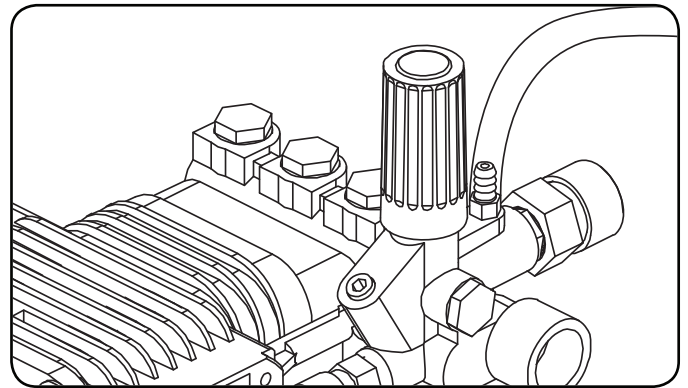

Place the filter end of the detergent hose into pressure washer detergent (not included).

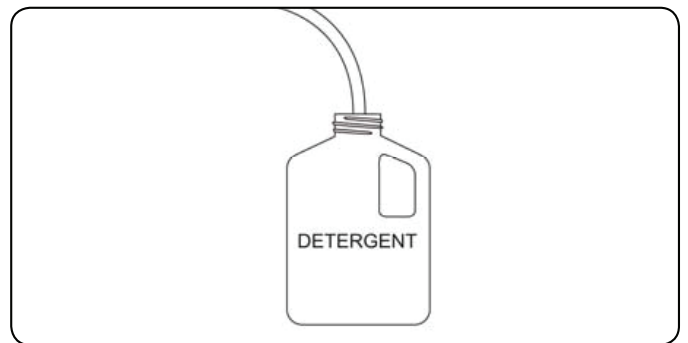

#### NOTE

Detergents can only be applied at low pressure setting.

# ASSEMBLY

## Add Engine Oil

### ! CAUTION

DO NOT attempt to crank or start the engine before it has been properly filled with the recommended type and amount of oil. Damage to the pressure washer as a result of failure to follow these instructions will void your warranty.

### NOTE

The recommended oil type is 10W-30 4-cycle automotive oil.

1. Place the pressure washer on a flat, level surface.

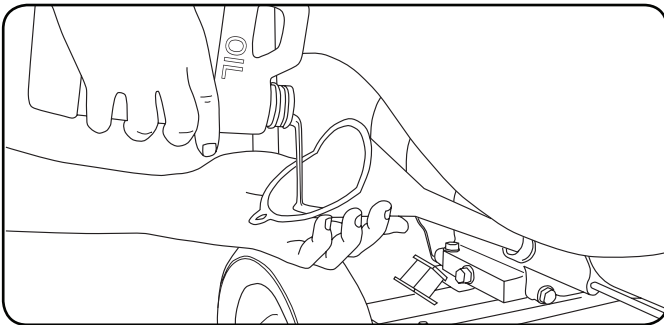

2. Remove oil fill cap/dipstick to add oil.
3. Add 0.6 L (0.63 qt.) of oil and replace oil fill cap/dipstick. Once oil has been added, a visual check should show oil about 1-2 threads from running out of the fill hole.

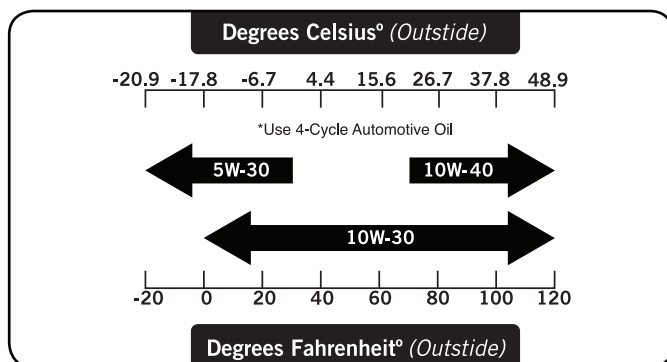

4. Check engine oil level daily and add as needed.

### CAUTION

The engine is equipped with a low-oil-shutoff and will stop when the oil level in the crankcase falls below the threshold level.

### NOTE

Check oil often during the break-in period. Refer to the Maintenance section for recommended service intervals.

## Add Engine Oil Cont'd.

### NOTE

The pressure washer engine shaft has a sealed, pre-lubricated ball bearing that requires no additional lubrication for the life of the bearing.

## Add Fuel

1. Use clean, fresh, regular unleaded fuel with a minimum octane rating of 85 and an ethanol content of less than 10% by volume.
2. DO NOT mix oil with fuel.
3. Clean the area around the fuel cap.
4. Remove the fuel cap.
5. Slowly add fuel to the tank. DO NOT overfill. Allow approximately ¼ inch of space for fuel expansion.

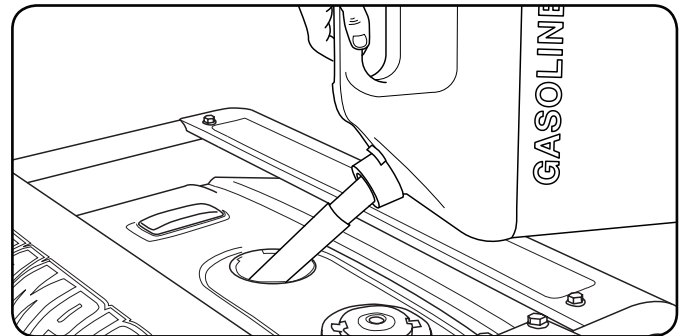

6. Screw on the fuel cap and wipe away any spilled fuel.

### ! CAUTION

Use regular unleaded gasoline with a minimum octane rating of 85.

Do not mix oil and gasoline.

Fill tank to approximately ¼" below the top of the tank to allow for fuel expansion.

DO NOT pump gas directly into the pressure washer at the gas station. Use an approved container to transfer the fuel to the pressure washer.

DO NOT fill fuel tank indoors.

DO NOT fill fuel tank when the engine is running or hot.

DO NOT overfill the fuel tank.

DO NOT light cigarettes or smoke when filling the fuel tank.

### ! WARNING

Pouring fuel too fast through the fuel screen may result in blow back of fuel at the operator while filling.

## Pressure Washer Location

This pressure washer must have at least 1.5 m (5 ft.) of clearance from combustible material. Leave at least 91 cm (3 ft.) of clearance on all sides of the pressure washer to allow for adequate cooling, maintenance and servicing. Place the pressure washer in a well ventilated area. DO NOT place the pressure washer near vents or intakes where exhaust fumes could be drawn into occupied or confined spaces. Carefully consider wind and air currents when positioning pressure washer.

## Before Starting the Engine

1. Turn the water ON.
2. Pull the trigger on the pressure gun to purge all air from the pump and hose. This may take several minutes.
3. Do not start the engine until a steady stream of water is flowing from the nozzle.

## Wireless Remote Start

Wireless remote starting is only possible **within 24 m (80 ft.)** of the pressure washer.

Do not attempt to adjust the carburetor choke. The remote system will automatically close and open the choke.

1. Make certain the pressure washer is on a flat, level surface.
2. Press the Ignition Switch to "ON."
3. Press the Battery Switch to "ON."
4. Turn the Fuel Valve to the "ON" position. (see below)

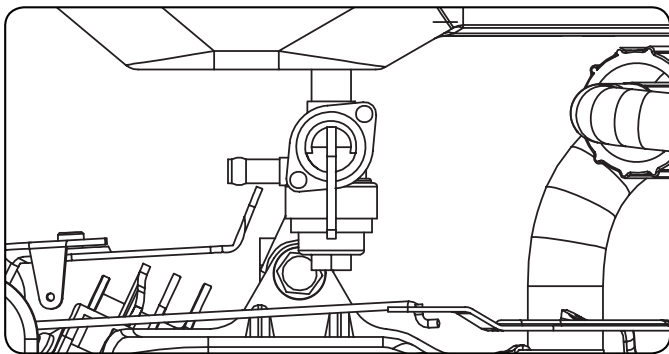

5. To start the engine, press and release the "START" button on the handheld Remote Control device. DO NOT hold the button down, only press the button once. The engine will attempt to start 6 times.
6. If the pressure washer fails to start, check the battery condition and cable connections.

## Starting the Engine without Remote

1. Make certain the pressure washer is on a flat, level surface.
2. Turn the Fuel Valve to the "ON" position.
3. Press the Battery Switch to "ON."
4. ELECTRIC START: Press and hold the ignition switch to the "START" position. Release as the engine begins to roll over. If the engine fails to start within five seconds, release the switch and wait at least ten seconds before attempting to start the engine again.
5. RECOIL START: Move the choke lever to the "CHOKE" position. Pull the starter cord slowly until resistance is felt and then pull rapidly. Do not over-choke. As soon as engine starts, move the choke lever to the "RUN" position.

### NOTE

Keep choke lever in "Choke" position for only 1 pull of the recoil starter. After first pull, move choke lever to the "Run" position for up to the next 3 pulls of the recoil starter. Too much choke leads to sparkplug fouling/engine flooding due to the lack of incoming air. This will cause the engine not to start.

### NOTE

If the engine does not start after 2 pulls, relieve pump pressure by pulling the trigger on the pressure washer gun.

### NOTE

If the engine starts but does not run make certain that the pressure washer is on a flat, level surface. The engine is equipped with a low oil sensor that will prevent the engine from running when the oil level falls below a critical threshold.

# OPERATION

## Distance from Cleaning Surface

The distance between the spray nozzle and the cleaning surface is another factor that affects the impact force of the water. The impact force of the water increases as the nozzle is moved closer to the surface. You can vary the impact force by controlling

1. The nozzle's fan pattern.
2. The nozzle's angle to the cleaning surface.
3. The nozzle's distance from the cleaning surface.

Never use a narrow high impact stream on a surface that is susceptible to damage. Avoid spraying windows with a narrow high impact stream or turbo nozzle. Doing so may break the glass.

1. Before triggering the gun, select a nozzle with a wide fan pattern.
2. Place the nozzle approximately 1.22 m (4 ft.) away from the cleaning surface. Then hold the nozzle at a 45 degree angle to the cleaning surface. Trigger the gun.
3. Vary the fan pattern spray angle and the distance to the cleaning surface until optimum cleaning efficiency is achieved without damaging the surface.

## High Pressure Wash

### CAUTION

Always engage the trigger safety latch when the unit is not in use.

The trigger safety latch prevents the gun from being triggered accidentally. Push the latch fully down to engage it.

Your unit is equipped with a quick connect nozzle port. Choose the appropriate nozzle tip for the job you are performing.

### CAUTION

The narrow high impact spray can damage some surfaces.

A wide fan pattern distributes the impact of the water over a larger area resulting in excellent cleaning action with reduced risk of surface damage. Clean large surface areas quickly using a wide fan pattern.

## Low Pressure Wash

### Detergent Use

The use of detergents can dramatically reduce cleaning time and assist in the removal of difficult stains. Many detergents are customized for pressure washer use on specific cleaning tasks. Pressure washer detergents are as thick as water. Using thicker detergents – like dish soap – will clog the chemical injection system.

### NOTE

Use only detergents specially formulated for pressure washers.

You can effectively clean surfaces by combining the chemical action of detergents with high pressure rinses. On vertical surfaces, apply the detergent starting at the bottom and work your way upward. This method prevents the detergent from sliding down and causing streaks. Begin high pressure rinsing at the bottom and work your way upward. On particularly tough stains, use a brush in combination with detergents and high pressure rinsing.

### System Flush

After using detergents, flush the suction system by placing the detergent suction tube into a bucket of clean water.

### WARNING

NEVER turn the water supply off before turning the engine/motor off.



## Depressurize System

To depressurize, turn engine/motor off, turn water supply off and squeeze gun trigger 2-3 times.

### **⚠ WARNING**

**NEVER** disconnect the high pressure discharge hose from the machine while the system is pressurized.

To reduce the risk of bodily injury or property damage, always follow this procedure whenever spraying is stopped, when work is completed, and before checking or repairing any part of the system.

1. Engage the trigger safety latch.
2. Turn the unit off.
3. Remove the ignition cable from the spark plug.
4. Shut off the water supply.
5. Disengage the trigger safety latch and trigger the gun to relieve pressure.
6. Re-engage the trigger safety latch.
7. Before overnight storage, long term storage, or transporting unit, disconnect the water supply and turn off the fuel supply valve.

## Operating Tips

### **⚠ CAUTION**

Never operate your pressure washer without water.

### **⚠ CAUTION**

Never connect your pressure washer to a hot water supply.

Connecting your pressure washer to a hot water source will significantly reduce the life of the pump and will void your warranty.

### **⚠ CAUTION**

Running the unit for more than one minute without spraying water causes heat to build up in the pump.

In the event that the pump gets too hot, a thermal relief valve will open to release the hot water. Running the unit without spraying water can damage pump components and will void your warranty.

## Stopping the Engine

1. Press the engine switch to the "Off" position.
2. Rotate the fuel valve to the "Off" position.

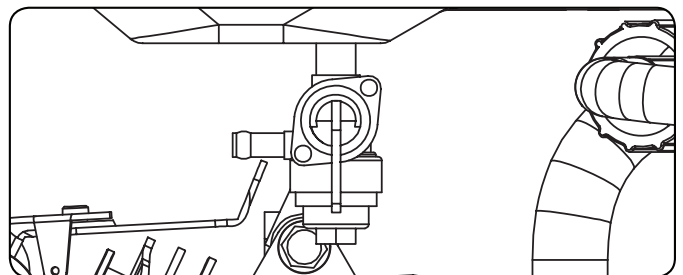

3. Depressurize system.
4. Turn off and unplug all hoses. Never start or stop the pressure washer unless the water supply is turned on.

# MAINTENANCE

The owner/operator is responsible for all periodic maintenance.

## ⚠ WARNING

Never operate a damaged or defective pressure washer.

## ⚠ WARNING

Improper maintenance will void your warranty.

## NOTE

Maintenance, replacement, or repair of emission control devices and systems may be performed by any non-road engine repair establishment or individual.

Complete all scheduled maintenance in a timely manner. Correct any issue before operating the pressure washer.

## NOTE

For service or parts assistance, contact our help line at **1-877-338-0999**

## Engine Maintenance

To prevent accidental starting, remove and ground spark plug wire before performing any service.

### Oil

Change oil when the engine is warm. Refer to the oil specification to select the proper grade of oil for your operating environment.

1. Remove oil fill cap/dipstick.
2. Use pliers to slide the spring clamp down the oil drain hose and pull the hose off the plug bracket.
3. Point the hose into a drain pan and allow the oil to drain completely. **Note:** The hose end must be lower than the engine base to allow the oil to drain.
4. Replace oil drain hose onto plug bracket and slide spring clamp back into position.
5. Add 0.6 L (0.63 qt.) of oil and replace oil fill cap/dipstick.
6. Dispose of used oil at an approved waste management facility.

### Oil Cont'd.

## NOTE

Once oil has been added, a visual check should show oil about 1-2 threads from running out of the fill hole. If using the dipstick to check oil level, **DO NOT** screw in the dipstick while checking.

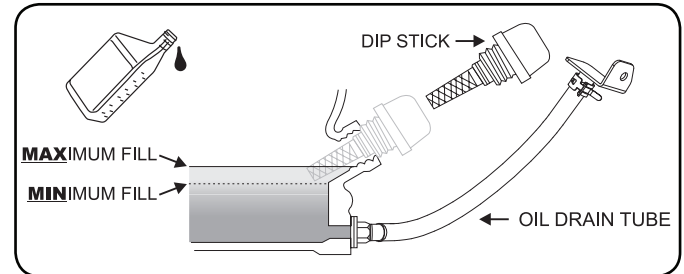

### Spark Plugs

1. Remove the spark plug cable from the spark plug.
2. Use the spark plug tool that shipped with your pressure washer to remove the plug.
3. Inspect the electrode on the plug. It must be clean and not worn to produce the spark required for ignition.

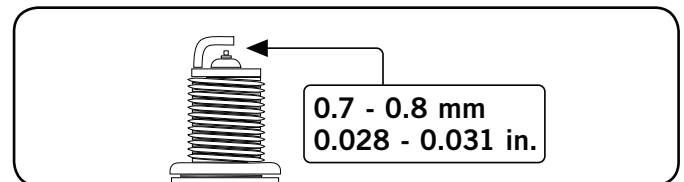

4. Make certain the spark plug gap is 0.7 - 0.8 mm or (0.028 - 0.031 in.).
5. Refer to the spark plug recommendation chart when replacing the plug.
6. Carefully thread the plug into the engine.
7. Use the spark plug tool to firmly install the plug.
8. Attach the spark plug wire to the plug.

## Air Filter

1. Remove the snap-on cover holding the air filter to the assembly.
2. Remove the foam element.
3. Wash in liquid detergent and water. Squeeze thoroughly dry in a clean cloth.
4. Saturate in clean engine oil.
5. Squeeze in a clean, absorbent cloth to remove all excess oil.
6. Place the filter in the assembly.
7. Reattach the air filter cover and snap in place.

## Cleaning

### ! CAUTION

DO NOT spray engine with water.

Water can contaminate the fuel system.

## Adjustments

CPE recommends that you contact our service line at **1-877-338-0999** for all other service and/or adjustment needs.

## Maintenance Schedule

Follow the service intervals indicated in the schedule below. Service your pressure washer more frequently when operating in adverse conditions.

Contact our help line at **1-877-338-0999** to locate the nearest Champion Power Equipment certified service dealer for your maintenance needs.

Every 8 hours or daily	
	Check oil level
	Clean around air intake and muffler
First 5 Hours	
	Change oil
Every 50 hours or every season	
	Clean air filter
	Change oil if operating under heavy load or in hot environments
Every 100 hours or every season	
	Change oil
	Clean/Adjust spark plug
	Check/Adjust valve clearance *
	Clean spark arrester
	Clean fuel tank and filter *
Every 3 years	
	Replace fuel line

\*To be performed by knowledgeable, experienced owners or Champion Power Equipment certified dealers.

## Pressure Washer Maintenance

Make certain that the pressure washer is kept clean and stored properly. Only operate the unit on a flat, level surface in a clean, dry operating environment. DO NOT expose the unit to extreme conditions, excessive dust, dirt, moisture or corrosive vapours.

### ! CAUTION

DO NOT use a garden hose to clean the pressure washer.

Use a damp cloth to clean exterior surfaces of the pressure washer.

Use a soft bristle brush to remove dirt and oil.

Use an air compressor (25 PSI) to clear dirt and debris from the pressure washer.

Inspect all air vents and cooling slots to ensure that they are clean and unobstructed.

## Cleaning Spray Nozzle

Detach the quick connect nozzle from the wand. Use a small wire rod (paper clip) to loosen up any particles in the quick connect nozzle and flush with water.

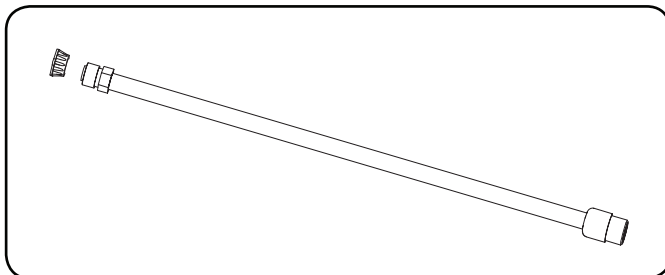

# STORAGE

## NOTE

Ignition switch should be in the "OFF" position while pulling the recoil cord, and performing storage maintenance steps.

## Storage

For long-term storage, please follow these guidelines.

### Engine Storage

1. Allow the engine to cool completely before storage.
2. Clean the engine according to the instructions in the Maintenance section.
3. Drain all fuel completely from the fuel line and carburetor to prevent gum from forming.
4. Add a fuel stabilizer into the fuel tank.
5. Change the oil.
6. Remove the spark plug and pour about 14 mL (1/2 oz.) of oil into the cylinder. Crank the engine slowly to distribute the oil and lubricate the cylinder.
7. Reattach the spark plug.

### Pressure Washer Storage

1. Allow the pressure washer to cool completely before storage.
2. Turn off the fuel supply at the fuel valve.
3. Clean the pressure washer according to the instructions in the Maintenance section.
4. Store the unit in a clean, dry area out of direct sunlight.

## ⚠ DANGER

Engine exhaust contains odourless and colourless carbon monoxide gas.

To avoid accidental or unintended ignition of your the pressure washer during periods of storage, the following precautions should be followed:

- When **storing the pressure washer for short periods of time** make sure that the Ignition Switch, the Fuel Valve and the Battery Switch are set in the **OFF** position.
- When **storing the pressure washer for extended periods of time** make sure that the Ignition Switch, the Fuel Valve and the Battery Switch are set in the the **OFF** position and the battery leads have been **disconnected** from the battery.

## Disconnect the Battery

1. Remove the protective cover from the black/negative battery lead.
2. Disconnect the black/negative lead from the black/negative terminal on the battery and store the cap screw (M5x12) and lock washer (M5).
3. Repeat steps 1-2 for the red/positive battery lead.
4. Store the battery in a cool, dry place.

## Charge the Battery

For pressure washers equipped with batteries for electric starting, proper battery maintenance and storage should be followed. An automatic battery charger with automatic trickle charging capability should be used to charge the battery. Maximum charging rate should not exceed 1.5 amps. Follow the instructions included with the battery charger. The battery should be fully charged at least once per month.

## NOTE

A Float Charger will maintain the battery condition over long storage periods.

## Winter Storage

Protect your pressure washer parts from freezing.

1. Apply all storage instructions from previous sections.
2. Make sure pressure washer hose is free of all water before storing for winter.
3. In order to prevent the pump from freezing you will need to insert RV antifreeze.
4. You will need approximately 6 ounces (177.44 mL) of RV Antifreeze, a funnel, and approximately 30 cm (12 in.) of garden hose or equivalent. See diagram below.

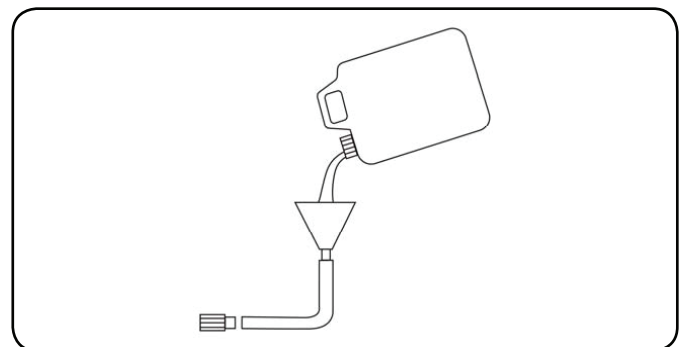

5. Pour the antifreeze into the funnel, then pull on the engine recoil starter to create suction in the pump housing. Pull the recoil several times until antifreeze comes out of the pump outlet.

## Engine Specifications

- Model ..... 66564
- Displacement ..... 196cc
- Type ..... 4-Stroke OHV
- Start Type ..... Wireless Remote

## Pressure Washer Specifications

- Model ..... 76554
- Max Pressure ..... 3000 PSI
- Flow Capacity ..... 2.5 GPM
- Fuel Capacity ..... 4 gal. (15.1 L)
- Gross Weight ..... 104.7 lb. (47.5 kg)
- Net Weight ..... 97 lb. (44 kg)
- Height ..... 23 in. (58.6 cm)
- Width ..... 24.1 in. (61.2 cm)
- Length ..... 28.9 in. (73.6 cm)

## Fuel

Fuel capacity is 15.1 L (4 gal.). Use regular unleaded gasoline with a minimum octane rating of 85 and an ethanol content of less than 10% by volume.

## Oil

Use 4-Cycle automotive oil.

Oil capacity is 0.6 L (0.63 qt.).

Please reference the following chart for recommended oil types for use in the pressure washer.

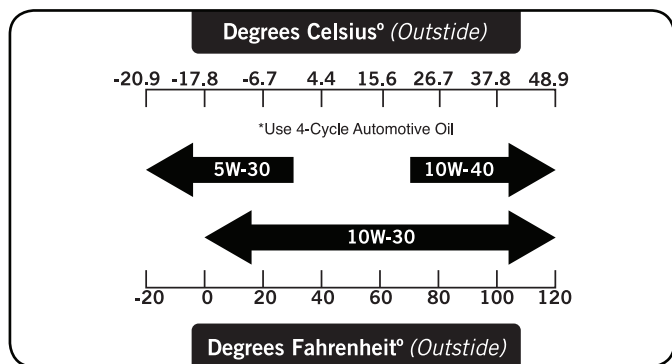

## Spark Plugs

**OEM spark plug:** NHSP F6RTC

**Replacement spark plug:** NGK BPR6ES or equivalent  
Make certain the spark plug gap is 0.7 - 0.8 mm or (0.028 - 0.031 in.).

## Maintenance Valve Clearance

- Intake: 0.13 – 0.17 mm (0.005 – 0.007 in.)
- Exhaust: 0.18 – 0.22 mm (0.007 – 0.009 in.)

Note: Tech bulletin regarding the valve adjustment procedure is on [www.championpowerequipment.com](http://www.championpowerequipment.com).

## IC Warning

This device complies with Industry Canada licence-exempt RSS standard(s).

Operation is subject to the following two conditions

- (1) This device may not cause interference, and
- (2) This device must accept any interference, including interference that may cause undesired operation of the device.

# SPECIFICATIONS

## Parts Diagram

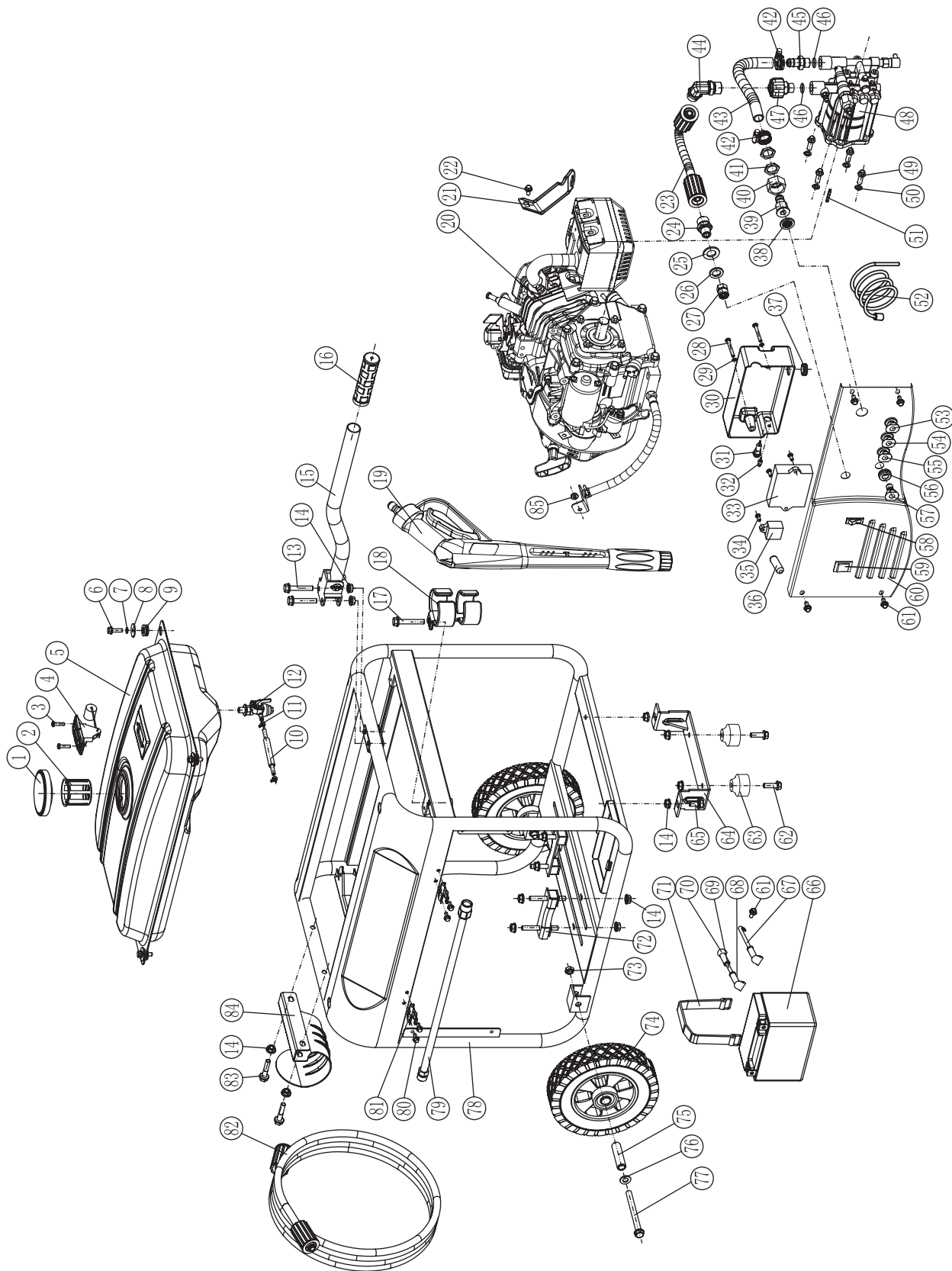

#	Part Number	Description	Qty
1	504.070100.02	Fuel Tank Cap	1
2	ST02FD-04130000	Fuel Filter	1
3	GB819 M5x10	Screw M5x10	2
4	ST02FD-04140000	Fuel Meter Assy	1
5	ST02FD-04110000 (Y)	Fuel Tank	1
6	GB5789 M6x20	Flange Bolt M6x20	4
7	GB93 6	Spring Washer 6	4
8	ST02FD-04100014	Washer 6.5	4
9	ST02FD-04100010	Tank Rubber	4
10	ST168FD-1160002	Fuel Line	1
11	ST188FD-1070006A	Clip	2
12	ST02FD-04160000	Fuel Cock	1
13	GB5789 M8x45	Flange Bolt M8x45	2
14	GB6177 M8	Nut M8	16
15	ST182FD-1151110-B	Handle	1
16	ST188FD-1741002-C	Handle sheath	1
17	GB5789 M8x50	Flange Bolt M8x50	1
18	819.252001.00	Gun set	1
19	820.252100.00	Gun assembly	1
20	168FDE-2-G3	Engine	1
21	ST168FD-1090006-A	Air Cleaner stay-LPG	1
22	GB5789 M6x8	Flange Bolt M6x8	1
23	819.250100.04	High pressure hose	1
24	819.250102.08	Connector(M22-R3/8)	1
25	GB96 16	Washer 16	1
26	ST160F-1030002	Oil filler cap packing	1
27	820.250102.00	Tie-in 3/8	1
28	GB823 M5x38	Screw M5x38	2
29	GB97.1 5	Washer 5	2
30	504.210002.10	Control Box	1
31	ST02FD-05612005	Indicator light	1
32	ST02FD-05612004	Button	1
33	WR05-00000000	Remote control	1
34	GB823 M5x14	Screw M5x14	3
35	EC02	Charger	1
36	ST02FD-05302010	FUSE(10A)	1
37	ST188FD-1020001	grommet	1
38	ST29QXG-3300200	Inlet filter gasket	1
39	820.250102.01	Tie-in	1
40	02.034000.10	Nut (NH3/4)	1
41	02.012000.20	Nut (M18x1)	2
42	06.195001.10	Clip	2
43	820.250100.01	Water hose(in)	1

#	Part Number	Description	Qty
44	819.250102.05	Right angle connector (out) M22-M22	1
45	819.250102.06	Connector (in) G3/8	1
46	07.014002.00	Rubber turn	2
47	819.250102.07	Connector (out) G3/8-M22	1
48	819.251000.02	Pump	1
49	ST29QXG-2000001	Flange Bolt	4
50	GB93 8	Spring washer 8	4
51	ST29QXG-2000006	Even key	1
52	822.250100.00	Chemical hose	1
53	ST36QXG-02100002-D	Nozzle"Detergent"	1
54	819.252300.06	Nozzle"40"	1
55	819.252300.05	Nozzle"25"	1
56	ST22QXP-2100003	Grommet	4
57	819.252300.04	Nozzle"15"	1
58	21.001000.02	Switch	1
59	29.001.00	Switch	1
60	2P11(F)	Control panel	1
61	GB5789 M6X12	Flange Bolt M6x12	5
62	GB5789 M8x25	Flange Bolt M8x25	2
63	816.201400.00	Vibration mount	2
64	ST05FD-03020301-60	Support leg	1
65	GB5789 M8x16	Flange Bolt M8x16	2
66	FM1290	9AH Battery	1
67	ST168FD-1750002-C7	Battery black wire(-)	1
68	ST168FD-1751002-A	Jacket	2
69	509.120500.01	Battery red wire(+)	1
70	ST05FD-03011112	Jacket	1
71	504.200904.00	Rubber belt	1
72	ST29QXG-2100200	Bottom Rubber	2
73	GB6182 M10	Nut M10	2
74	ST177FD-1152300	8in Wheel	2
75	ST02FD-03621001	Bush 10.5x58.5	2
76	GB96 10	Flat washer 10	2
77	GB5782 M10x105	Bolt M10x105	2
78	819.201100.03(F)	Frame	1
79	819.252200.00	Connect wand	1
80	GB16674 M5X12	Flange Bolt M5x12	4
81	819.200015.00	Steel pipe fixed	2
82	819.250100.02	High pressure hose	1
83	GB5789 M8x40	Flange Bolt M8x40	2
84	819.200012.03(F)	Pothead	1
85	GB6177 M6	Nut M6	1

# SPECIFICATIONS

## Engine Parts Diagram

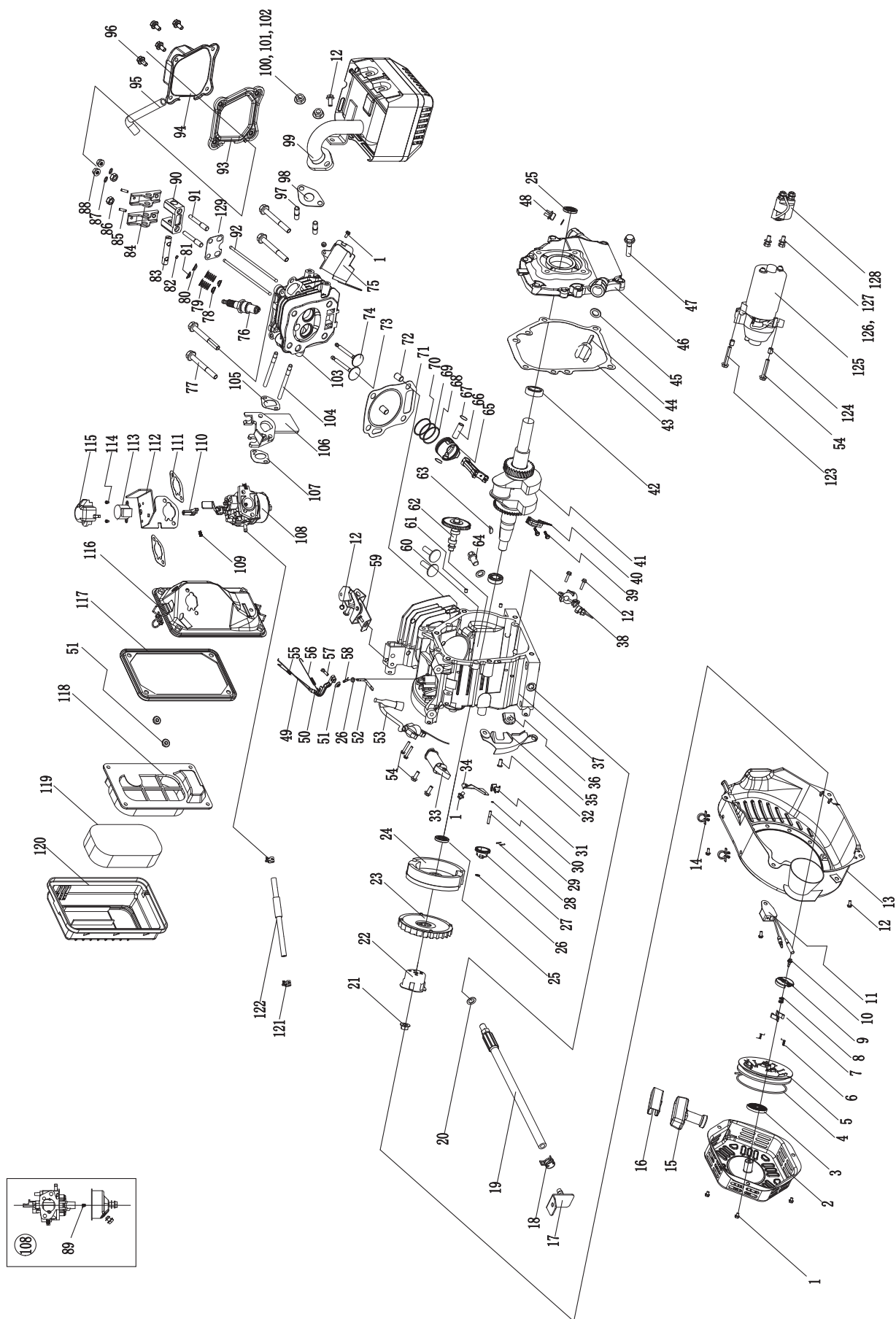



#	Part Number	Description	Qty
1	GB5789--86-FB6-8	Flange bolt M6*8	6
2	ST160F--1061100-Q	Case,Recoil Assembly	1
3	ST160F--1061005	Return spring,Recoil Assembly	1
4	ST160F--1061009	Rope,Recoil Assembly	1
5	ST160F--1061001-A	Pulley,Assembly	1
6	ST188F-1060006	Ratchet Spring	2
7	ST188F-1060005	Ratchet Starter	2
8	ST188F-1060004	Spring,Ratchet Guide	1
9	ST188F-1060003	Ratchet guide	1
10	ST188F-1060002	Bolt,Ratchet Guide	1
11	ST160F-1126000	Diode	1
12	GB5789--86-FB6-12	Flange bolt M6*12	9
13	168.080100.06	Fan cover Assembly	1
14	ST188FD-1130004	Clamp	2
15	ST160F--1061202	Knob Recoil Assembly	1
16	ST160F--1061201	Core,Knob	1
17	190.030200.00	SUPPORT	1
18	06.135010.20	CLIP,Oil Tube	1
19	168.032000.00	Guide Tubing Assembly	1
20	ST160F--1030004	washer,Drain bolt	2
21	ST160F--1050010	Nut M14	1
22	ST160F--1060001-A	Start Hoop	1
23	ST168F--1080001	Cooling fan	1
24	ST168F--1120100-A	Flywheel Assembly	1
25	ST168F--1030100	Oil seal	2
26	ST160F--1110108	Washer,Governor Gear	2
27	ST160F--1110101	Governor Gear	1
28	ST160F--1110102	Pin,Governor Weight	2
29	ST160F--1110104	Shaft,Governor Gear	1
30	ST160F--1110103	Clip,Governor Gear	1
31	ST160F--1110107	Governor weight	2
32	ST160F--1110105	Bushing,Governor Gear	1
33	ST188F-1123000	Electrify coil	1
34	ST168F-1180002	Plate,Wire	1
35	ST168F--1080200-A	Air Shroud	1
36	ST188F-1030012	Sheath, wire	1
37	ST168F-2-1030012-G	Crankcase for USA	1
38	ST160F-1127000-A	Oil Level Sensor	1
39	GB5758 AM7x35	Flange bolt ,Connecting Rod	2
40	ST168F--1050100	Connecting Rod Assembly	1
41	ST168F-2-1050001-Q	Crankshaft Assembly	1
42	GB/T--276--94	Radial ball bearing 6205	2
43	ST168F-1030008-G	Gasket,Crankcase	1
44	ST160F--1030001-B	Oil filler assembly	1
45	ST160F--1030002	Gasket,Oil filler cap	2
46	ST168F-1030007-G	Crankcase cover for USA	1
47	GB5789--86-FB8-32	Flange bolt 8*32	6
48	ST160F--1030005-B	Oil filler cap	1
49	ST168F--1110006	Rod,Joint	1
50	ST160F--1110003	Arm,Governor	1
51	GB6177--86-N6	Nut M6	3
52	ST160F--1110001	Shaft Governor Arm	1
53	ST160F-1123000-A	Ignition Coil	1
54	GB5789--86-FB6-25	Flange bolt 6*25	5
55	ST168F--1110005	Spring Throttle Return	1
56	ST168F--1110007	Spring,Governor	1
57	ST160F--1110004	Bolt,Governor Arm	1
58	ST160F--1110008	Pin,Shaft	1
59	ST168FD-1111100	Controller assembly	1
60	ST168F-2-1040013	Valve lifter	2
61	ST168F-1030015-G	Dowel pin 9*14	2
62	ST168F-2-1041000	Camshaft assembly	1
63	GB1099-79	Key	1
64	ST160F--1030003	Drain bolt	1
65	ST168F-2-1050005	Piston	1

#	Part Number	Description	Qty
66	ST168F--1050003	Piston pin	1
67	ST168F--1050004	clip,Piston pin	2
68	ST168F--1050200	Ring,Oil	1
69	ST168F--1050006	Ring,Second Piston	1
70	ST168F--1050007	Ring,First Piston	1
71	ST168F-2-1030009-G	gasket,Cylinder head	1
72	152FMD--1001007	Dowel pin 10*16	2
73	ST168F--1040002	Valve,Intake	1
74	ST168F--1040006	Valve,Exhaust	1
75	ST168F--1080002-G	Air Shroud,Cylinder	1
76	F6RTC	Spark plug	1
77	GB5789--86-FB8-55	Flange bolt 8*55	4
78	ST168F-1040014	Oil Seal,Valve	2
79	ST160F--1040003	Spring,Valve	2
80	ST160F--1040007	Retainer Exshhaust Valve	1
81	ST160F--1040001	Retainer Intake Valve	1
82	ST160F--1040008	Rotator Exhaust Valve	1
83	168.040202.34	Shaft,Rocker Arm	1
84	ST160F--1040022	Rocker Arm, Valve	2
85	ST160F--1040024	Screw,Valve Adjustment	2
86	ST160F--1040025	Lock Nut	2
87	GB97.1 6	washer 6	2
88	GB6183-86-M6	Nut M6	2
89	ST168FD-2-1131000-17	standard main jet	1
90	168.040201.34	Retainer, Rocker Arm	1
91	ST168F--1040027	Stud, bolt	2
92	ST168F--1040005	Push rod	2
93	ST160F--1020002-A	Gasket,Cylinder Head Cover	1
94	ST168F--1020100-C	Cylinder Head Cover	1
95	ST160FD--1020011	Breather tube	1
96	GB5789--86-FB6-15	Flange bolt M6*15	4
97	ST160F-1010002	Stud, bolt	2
98	ST168F-1100200-G	Gasket,Muffler	1
99	468.101000.03	Muffler Assembly	1
100	GB848-85-W8	washer 8	2
101	GB859-87-SW8	Lock washer 8	2
102	GB6170--86-N8	Nut M8	2
103	ST168F-2-1010100-G	Cylinder head Assembly	1
104	ST168FD-1010001	Stud, bolt 6*90	2
105	ST160F--1130002-CPE	Gasket,Heat Shield Board	1
106	ST168F--1130001	Heat Shield Board	1
107	ST160F--1130003-CPE	Gasket,Carburetor	1
108	468.131000.02	Carburetor	1
109	0902.130010.00	Spring,Connector.	1
110	168.130015.01	Connector,Starter	1
111	ST168FD--1130004	Gasket,Air Cleaner	2
112	168.130005.01	Support,Stepper Motor	1
113	188.132200.00	Stepper Motor Assembly	1
114	GB818 M4x8	Screw M4x8	2
115	0902.132001.00	Cover,Stepper Motor	1
116	ST168FD--1091000	Base,Air Cleaner	1
117	ST168FD--1090002	seal,Air cleaner	1
118	ST168FD--1090001	Separator,Cleaner	1
119	ST168FD--1090004	Element,Air Cleaner	1
120	ST168FD--1090200-G	Cover,Air Cleaner	1
121	ST188FD-1070006-A	Clip	2
122	ST188FD-1160002-CPE	Fuel Tube	1
123	GB5789--86-FB6-29	Flange bolt 6*29	1
124	ST168F-1180001	Dowel pin 8x10	2
125	ST168F-1181100	Start motor	1
126	GB29.2-88-FB5-16	Flange bolt M5x16	2
127	GB93-87-SW5	Lock washer 5	2
128	168.125200.01	Relay Starter	1
129	168.040004.34	Guide,Push Rod	1

# TROUBLESHOOTING

Problem	Cause	Solution
Pressure washer will not start	No fuel	Add fuel
	Faulty spark plug	Replace spark plug
Pressure washer will not start; Pressure washer starts but runs roughly	Low oil level	Fill crankcase to the proper level Place pressure washer on a flat, level surface
	Choke in the wrong position	Adjust choke
	Spark plug wire loose	Attach wire to spark plug
Pressure washer gallops	Engine governor defective	Contact the help line
Unit does not reach high pressure	Water supply is restricted	Check hoses for leaks, blockage, kinks
	Garden hose is too small	Replace with 5/8 in. garden hose or larger
	Garden hose inlet filter is clogged	Remove garden hose, clean filter and rinse out
	Not enough inlet water	Turn garden hose water on full force
Spray pressure varies from high to low	Poor inlet water supply	Turn garden hose water on full force. Check hose for leaks, blockage, or kinks
	Garden hose inlet filter is clogged	Remove garden hose, clean filter and rinse out
	Spray nozzle is obstructed	Remove particles with small wire rod (see maintenance section in manual)
	Pump is sucking air	Check all hoses and fittings, make sure they are securely tightened down and fastened. Turn off engine and purge pump by squeezing trigger gun until a steady stream of water flows
Detergent wash is not functioning properly	Detergent is too thick	Dilute detergent
	Wand is on high pressure setting	Detergent only works on a low pressure setting
	Detergent hose is not connected to the pump housing	Check connection. See diagram on Page 10
	Spray nozzle is obstructed	Clean nozzle and remove debris
	Filter on detergent hose is clogged	Clean with warm water or replace
	Chemical Injector valve (inside pump) partially blocked or stuck	Quickly pull and release the gun trigger 4-5 time to clear the chemical injector valve
Garden hose connection leaks	Loose fittings	Tighten
	Missing/worn-out rubber washer	Replace rubber washer
Spray wand leaks	Spray wand not properly attached	Tighten all connections
Pressure Washer is difficult to start using Electric/Remote Start Pressure Washer will not start using Electric/Remote Start	Stuck EZ-Start Valve inside Pump	Pull the Gun Trigger while starting the Pressure Washer Contact Tech Support if the Pressure Washer continues to build pressure during starting.

## For further technical support:

### Technical Service

Mon – Fri 8:30 AM – 5:00 PM (PST/PDT)

Toll Free: 1-877-338-0999

tech@championpowerequipment.com

**WARRANTY****CHAMPION POWER EQUIPMENT  
1 YEAR LIMITED WARRANTY**

Effective September 1, 2006. Replaces all undated warranties and all warranties dated before September 1, 2006.

**Warranty Qualifications**

Champion Power Equipment (CPE) will register this warranty upon receipt of your Warranty Registration Card and a copy of your sales receipt from one of CPE's retail locations as proof of purchase.

Please submit your warranty registration and your proof of purchase within ten (10) days of the date of purchase.

**Repair/Replacement Warranty**

CPE warrants to the original purchaser that the mechanical and electrical components will be free of defects in material and workmanship for a period of one (1) year from the original date of purchase (90 days for commercial and industrial use). Transportation charges on product submitted for repair or replacement under this

warranty are the sole responsibility of the purchaser. This warranty only applies to the original purchaser and is not transferable.

**Do Not Return The Unit To The Place Of Purchase**

Contact CPE's Technical Service and CPE will troubleshoot any issue via phone or e-mail. If the problem is not corrected by this method, CPE will, at its option, authorize evaluation, repair or replacement of the defective part or component at a CPE Service Center. CPE will provide you with a case number for warranty service. Please keep it for future reference. Repairs or replacements without prior authorization, or at an unauthorized repair facility, will not be covered by this warranty.

**Warranty Exclusions**

This warranty does not cover the following repairs and equipment:

**Normal Wear**

Pressure washers need periodic parts and service to perform well. This warranty does not cover repair when normal use has exhausted the life of a part or the equipment as a whole.

**Installation, Use and Maintenance**

This warranty will not apply to parts and/or labor if this pressure washer is deemed to have been misused, neglected, involved in an accident, abused, loaded beyond the pressure washer's limits, modified, installed improperly or connected incorrectly to any water supply.

**Installation, Use and Maintenance Cont'd.**

Normal maintenance such as spark plugs, air filters, adjustments, fuel system cleaning and obstruction due to buildup is not covered by this warranty.

**Other Exclusions**

This warranty excludes:

- Cosmetic defects such as paint, decals, etc.
  - Wear items such as filter elements, o-rings, etc.
  - Accessory parts such as starting batteries, and storage covers.
  - Failures due to acts of God and other force majeure events beyond the manufacturer's control.
- Problems cause by parts that are not original Champion Power Equipment parts.

**Limits of Implied Warranty and Consequential Damage**

Champion Power Equipment disclaims any obligation to cover any loss of time, use of this product, freight, or any incidental or consequential claim by anyone from using this pressure washer. THIS WARRANTY IS IN LIEU OF ALL OTHER WARRANTIES, EXPRESS OR IMPLIED, INCLUDING WARRANTIES OF MERCHANTABILITY OR FITNESS FOR A PARTICULAR PURPOSE.

A unit provided as an exchange will be subject to the warranty of the original unit. The length of the warranty governing the exchanged unit will remain calculated by reference to the purchase date of the original unit.

This warranty gives you certain legal rights which may change from state to state. Your state may also have other rights you may be entitled to that are not listed within this warranty.

**Contact Information****Address**

Champion Power Equipment, Inc.  
Customer Service  
10006 Santa Fe Springs Rd.  
Santa Fe Springs, CA 90670  
[www.championpowerequipment.com](http://www.championpowerequipment.com)

**Customer Service**

Mon – Fri 8:30 AM – 5:00 PM (PST/PDT)  
Toll Free: 1-877-338-0999  
[info@championpowerequipment.com](mailto:info@championpowerequipment.com)  
Fax no.: 1-562-236-9429

**Technical Service**

Mon – Fri 8:30 AM – 5:00 PM (PST/PDT)  
Toll Free: 1-877-338-0999  
[tech@championpowerequipment.com](mailto:tech@championpowerequipment.com)  
24/7 Tech Support: 562-204-1188

**Champion Power Equipment, Inc (CPE),  
Emission Control System Warranty**

Your Champion Power Equipment (CPE) engine complies with Environment Canada (EC) emission regulations.

**YOUR WARRANTY RIGHTS AND OBLIGATIONS:**

CPE is pleased to explain the Emission Control Systems Warranty on your 2012 small off-road engine. New engines must be designed, built and equipped, at the time of sale, to meet EC regulations for small non-road engines. CPE must warrant the emission control system on your small off-road engine for the period of time listed below, provided there has been no abuse, neglect, unapproved modification, or improper maintenance of your small off-road engine.

Your emission control system may include parts such as the carburetor, fuel-injection system, the ignition system, catalytic converter and fuel lines. Also included may be hoses, belts, connectors and other emission related assemblies. Where a warrantable condition exists, CPE will repair your small off-road engine at no cost to you including diagnosis, parts and labor.

**MANUFACTURER'S EMISSION CONTROL SYSTEM WARRANTY COVERAGE:**

This emission control system is warranted for two years, subject to provisions set forth below. If, during the warranty period, emission related part on your engine is defective in materials or workmanship, the part will be repaired or replaced by CPE.

**OWNER WARRANTY RESPONSIBILITIES:**

As the small off-road engine owner, you are responsible for the performance of the required maintenance listed in your Owner's Manual. CPE recommends that you retain all your receipts covering maintenance on your small off-road engine, but CPE cannot deny warranty solely for the lack of receipts or for your failure to ensure the performance of all scheduled maintenance.

**As the small off-road engine owner, you should however be aware that CPE may deny you warranty coverage if your small, off-road engine or a part has failed due to abuse, neglect, improper maintenance or unapproved modifications.**

You are responsible for presenting your small off-road engine to an Authorized CPE service outlet, CPE dealer or CPE, Santa Fe Springs, CA., USA as soon as a problem exists. The warranty repairs should be completed in a reasonable amount of time, not to exceed 30 days.

If you have any questions regarding your warranty rights and responsibilities, you should contact:

Champion Power Equipment, Inc.  
Customer Service  
10006 Santa Fe Springs Road  
Santa Fe Springs, CA 90670  
USA  
Tel: 1-877-338-0999

The emission warranty is a defects warranty. Defects are judged on normal engine performance. The warranty is not related to an in-use emission test.

## **EMISSION CONTROL SYSTEM WARRANTY**

**The following are specific provisions relative to your Emission Control System Warranty Coverage.**

Emission Control System Warranty (ECS Warranty):

**1. APPLICABILITY:** The ECS Warranty Period shall begin on the date the new engine or equipment is delivered to its original, end-use purchaser, and shall continue for 24 consecutive months thereafter.

### **2. GENERAL EMISSIONS WARRANTY COVERAGE**

CPE warrants to the original, end-use purchaser of the new engine or equipment and to each subsequent purchaser that each of its small off-road engines is:

a. Designed, built and equipped so as to conform at the time of sale with applicable regulations under the Canadian Environmental Protection Act, 1999 (CEPA 1999).

b. Free from defects in materials and workmanship that cause the failure of a warranted part to be identical in all material respects to the part as described in the engine manufacturer's application for certification for a period of two years.

### **3. THE WARRANTY ON EMISSION-RELATED PARTS WILL BE INTERPRETED AS FOLLOWS:**

a. Any warranted part that is not scheduled for replacement as required maintenance in the Owners Manual shall be warranted for the ECS Warranty Period. If any such part fails during the ECS Warranty Period, it shall be repaired or replaced by CPE according to Subsection "d" below. Any such part repaired or replaced under the ECS Warranty shall be warranted for any remainder of the ECS Warranty Period.

b. Any warranted, emissions-related part which is scheduled only for regular inspection as specified in the Owners Manual shall be warranted for the ECS Warranty Period. A statement in such written instructions to the effect of "repair or replace as necessary", shall not reduce the ECS Warranty Period. Any such part repaired or replaced under the ECS Warranty shall be warranted for the remainder of the ECS Warranty Period.

c. Any warranted, emissions-related part which is scheduled for replacement as required maintenance in the Owner's Manual shall be warranted for the period of time prior to the first scheduled replacement point for that part. If the part fails prior to the first scheduled replacement, the part shall be repaired or replaced by CPE according to Subsection "d" below. Any such emissions-related part repaired or replaced under the ECS Warranty, shall be warranted for the remainder of the ECS Warranty Period prior to the first scheduled replacement point for such emissions-related part.

d. Repair or replacement of any warranted, emissions-related part under this ECS Warranty shall be performed at no charge to the owner at a CPE Authorized Service Outlet.

e. The owner shall not be charged for diagnostic labor which leads to the determination that a part covered by the ECS Warranty is in fact defective, provided that such diagnostic work is performed at a CPE Authorized Service Outlet.

f. CPE shall be liable for damages to other original engine components or approved modifications proximately caused by a failure under warranty of an emission-related part covered by the ECS Warranty.

g. Throughout the ECS Warranty Period, CPE shall maintain a supply of warranted emission-related parts sufficient to meet the expected demand for such emission-related parts.

h. Any CPE Authorized and approved emission-related replacement part may be used in the performance of any ECS Warranty maintenance or repair and will be provided without charge to the owner. Such use shall not reduce CPE's warranty obligation.

i. Unapproved add-on or modified parts may not be used to modify or repair a CPE engine. Such use voids this ECS Warranty and shall be sufficient grounds for disallowing an ECS Warranty claim. CPE shall not be liable hereunder for failures of any warranted parts of a CPE engine caused by the use of such an unapproved add-on or modified part.

**EMISSION-RELATED PARTS INCLUDE THE FOLLOWING: (using those portions of the list applicable to the engine)**

Systems covered by this warranty	Parts Description
Fuel Metering System	Fuel regulator, Carburetor and internal parts
Air Induction System	Air cleaner, Intake manifold
Ignition System	Spark plug and parts, Magneto ignition system
Exhaust System	Exhaust manifold, catalytic converter
Miscellaneous Parts	Tubing, Fittings, Seals, Gaskets, and Clamps associated with these listed systems.

**TO OBTAIN WARRANTY SERVICE:**

You must take your CPE engine or the product on which it is installed, along with your warranty registration card or other proof of original purchase date, at your expense, to any Champion Power Equipment dealer who is authorized by Champion Power Equipment, Inc. to sell and service that CPE product during his normal business hours. Claims for repair or adjustment found to be caused solely by defects in material or workmanship will not be denied because the engine was not properly maintained and used.

**If you have any questions regarding your warranty rights and responsibilities, or to obtain warranty service, please write or call Customer Service at Champion Power Equipment, Inc.**

**Champion Power Equipment, Inc.  
10006 Santa Fe Springs Road  
Santa Fe Springs, CA 90670  
USA  
1-877-338-0999  
Attn: Customer Service**