

CHAMPION

POWER EQUIPMENT™

76552

Rev 76552-20100601



10006 Santa Fe Springs Road
Santa Fe Springs, CA 90670 USA
Made in China

Owner's Manual and Operating Instructions

SAVE THESE INSTRUCTIONS

**Important Safety
Instructions are included in
this manual**



3000 PSI – 2.5 GPM

PRESSURE WASHER

Table of Contents

Introduction	1	Storage	14
Pressure Washer	1	Engine Storage	14
Accessories	1	Pressure Washer Storage	14
This Booklet	1	Winter Storage	14
Manual Conventions	2	Specifications	15
Safety Rules	3	Engine Specifications	15
Controls and Features	6	Pressure Washer Specifications	15
Pressure Washer	6	Fuel	15
Parts Included	7	Oil	15
Assembly	8	Spark Plugs	15
Remove the Pressure Washer from the		Valve Clearance	15
Shipping Carton	8	Pressure Washer Parts Diagram	16
Add Engine Oil	8	Pressure Washer Parts List	17
Add Fuel	8	Engine Parts Diagram	18
Install the Hoses	8	Engine Parts List	19
Attach the Pressure Gun	8	Troubleshooting	22
Connect to Garden Hose	8	Warranty	23
Operation	9	Warranty Qualifications	23
Pressure Washer Location	9	Repair/Replacement Warranty	23
Before Starting the Engine	9	Do not return the unit to the place of	
Starting the Engine	9	purchase	23
High Pressure Wash	9	Warranty Exclusions	23
Distance from Cleaning Surface	10	Normal Wear	23
Low Pressure Wash	10	Installation, Use and Maintenance	23
Detergent Use	10	Other Exclusions	23
System Flush	10	Limits of Implied Warranty and	
Depressurize System	10	Consequential Damage	23
Operating Tips	11	Contact Information	23
Stopping the Engine	11	Address	23
Maintenance	12	Customer Service	23
Engine Maintenance	12	Technical Service	23
Oil	12		
Spark Plugs	12		
Air Filter	12		
Cleaning	13		
Adjustments	13		
Maintenance Schedule	13		
Pressure Washer Maintenance	13		
Cleaning Spray Nozzle	13		

Introduction

Congratulations on your purchase of a Champion Power Equipment pressure washer. CPE designs and builds pressure washers to strict specifications. With proper use and maintenance, this pressure washer will bring years of satisfying service.

This Owner's Manual contains important safety instructions and information. **SAVE THESE INSTRUCTIONS FOR FUTURE REFERENCE.**

Pressure Washer

This unit is a gasoline engine driven pressure washer. It is designed for use in cleaning with or without detergent and is suitable for decks, patios, house siding, vehicles, lawn furniture, barbecue grills, gardening tools and more.

Record the model and serial numbers as well as date and place of purchase for future reference. Have this information available when ordering parts and when making technical or warranty inquiries.

Champion Power Equipment Support
1-877-338-0999
Model Number
76552
Serial Number
Date of Purchase
Purchase Location

Accessories

Champion Power Equipment manufactures and sells accessories designed to help you get the most from your purchase. To find out more about our accessories, please visit our web site at

www.championpowerequipment.com

This Booklet

Every effort has been made to ensure the accuracy and completeness of the information in this manual. We reserve the right to change, alter and/or improve the product and this document at any time without prior notice.

Manual Conventions

Manual Conventions

This manual uses the following symbols to help differentiate between different kinds of information. The safety symbol is used with a key word to alert you to potential hazards in operating and owning power equipment.

Follow all safety messages to avoid or reduce the risk of serious injury or death.

DANGER

DANGER indicates an imminently hazardous situation which, if not avoided, *will* result in death or serious injury.

WARNING

WARNING indicates a potentially hazardous situation which, if not avoided, *could* result in death or serious injury.

CAUTION

CAUTION indicates a potentially hazardous situation which, if not avoided, *may* result in minor or moderate injury.

CAUTION

CAUTION used without the safety alert symbol indicates a potentially hazardous situation which, if not avoided, *may* result in property damage.

NOTE

If you have questions regarding your pressure washer, we can help. Please call our help line at 1-877-338-0999.

Safety Rules

WARNING

Read this manual thoroughly before operating your pressure washer. Failure to follow instructions could result in serious injury or death.

WARNING

The engine exhaust from this product contains chemicals known to the state of California to cause cancer, birth defects, or other reproductive harm.

DANGER

Engine exhaust contains carbon monoxide, a colorless, odorless, poison gas. Breathing carbon monoxide will cause nausea, dizziness, fainting or death. If you start to feel dizzy or weak, get to fresh air immediately.

Operate pressure washer outdoors only in a well ventilated area
DO NOT operate the pressure washer inside any building, including garages, basements, crawlspaces and sheds, enclosure or compartment, including the generator compartment of a recreational vehicle.
DO NOT allow exhaust fumes to enter a confined area through windows, doors, vents or other openings.
DANGER CARBON MONOXIDE, using a pressure washer indoors **CAN KILL YOU IN MINUTES**.

DANGER

Rotating parts can entangle hands, feet, hair, clothing and/or accessories.

Traumatic amputation or severe laceration can result.

Keep hands and feet away from rotating parts. Tie up long hair and remove jewelry. Operate equipment with guards in place. DO NOT wear loose-fitting clothing, dangling drawstrings or items that could become caught.

WARNING

Sparks can result in fire or electrical shock.

When servicing the pressure washer: Disconnect the spark plug wire and place it where it cannot contact the plug. DO NOT check for spark with the plug removed. Use only approved spark plug testers.

WARNING

Running engines produce heat. Severe burns can occur on contact. Combustible material can catch fire on contact.

DO NOT touch hot surfaces. Avoid contact with hot exhaust gases. Allow equipment to cool before touching. Maintain at least three feet of clearance on all sides to ensure adequate cooling. Maintain at least five feet of clearance from combustible materials.

WARNING

Rapid retraction of the starter cord will pull hand and arm towards the engine faster than you can let go.

Unintentional startup can result in entanglement, traumatic amputation or laceration.

Broken bones, fractures, bruises or sprains could result.

When starting engine, pull the starter cord slowly until resistance is felt and then pull rapidly to avoid kickback.

Safety Rules

DANGER

Fuel and fuel vapors are highly flammable and extremely explosive.

Fire or explosion can cause severe burns or death.

Unintentional startup can result in entanglement, traumatic amputation or laceration.

When adding or removing fuel

Turn the engine off and let it cool for at least two minutes before removing the fuel cap. Loosen the cap slowly to relieve pressure in the tank. Only fill or drain fuel outdoors in a well-ventilated area.

DO NOT overfill the fuel tank.

Always keep fuel away from sparks, open flames, pilot lights, heat and other sources of ignition.

DO NOT light or smoke cigarettes.

When starting the pressure washer

DO NOT attempt to start a damaged pressure washer.

Make certain that the gas cap, air filter, spark plug, fuel lines and exhaust system are properly in place.

Allow spilled fuel to evaporate fully before attempting to start the engine.

Make certain that the pressure washer is resting firmly on level ground.

When operating the pressure washer:

DO NOT move or tip the pressure washer during operation.

DO NOT tip the pressure washer or allow fuel or oil to spill.

When transporting or servicing the pressure washer:

Make certain that the ignition switch is in the off position and the fuel tank is empty.

Disconnect the spark plug wire.

When storing the pressure washer:

Store away from sparks, open flames, pilot lights, heat and other sources of ignition.

CAUTION

Improper treatment or use of the pressure washer can damage it, shorten its life and void your warranty.

Use the pressure washer only for intended uses. Operate only on level surfaces.

DO NOT expose pressure washer to excessive moisture, dust, or dirt.

DO NOT allow any material to block the cooling slots.

DO NOT use the pressure washer if:

Equipment sparks, smokes or emits flames

Equipment vibrates excessively

DANGER

Keep clear of nozzle.

DO NOT point the pressure wand at a person, an animal or yourself.

Always wear safety glasses or goggles and protective equipment (hearing protection, gloves, rubber boots, protective clothing) when operating or performing maintenance.

- Never put hand or fingers over the spray tip while operating the unit.
- Never try to stop or deflect leaks with any body part.
- Always engage the trigger safety latch in the safe position when spraying is stopped even if only for a few moments.

WARNING

NEVER spray flammable liquids or use pressure washer in areas containing combustible dust, liquids, or vapors.

NEVER operate this machine in a closed building or in or near an explosive environment.

- DO NOT remove fuel tank cap or fill fuel tank while engine is hot or running (allow engine to cool two minutes before refueling). Always fill the tank slowly.
- Never disconnect the high pressure discharge hose from the machine while the system is pressurized.

CAUTION

NEVER run the unit dry.

Be sure the water supply is completely turned on before operating the unit.



WARNING

DO NOT let water in the pump freeze.

See Storage section in the manual for instructions regarding winter storage.

If water has frozen in the pressure washer, thaw the pressure washer in a warm room before starting.

DO NOT pour hot water on or into the pump; internal parts will be damaged and your warranty will be voided.

Controls and Features

Controls and Features

Read this owner's manual before operating your pressure washer. Familiarize yourself with the location and function of the controls and features. Save this manual for future reference.

Pressure Washer

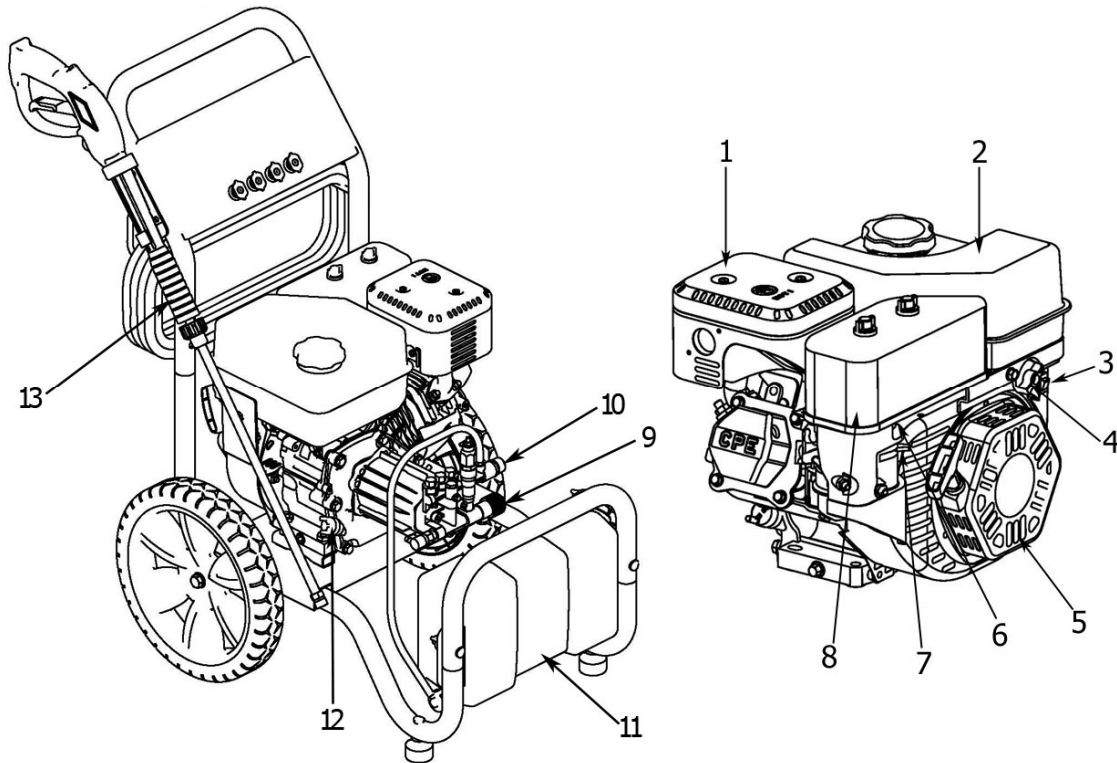

(1) Muffler

(2) Fuel Tank

(3) Engine Switch

(4) Fuel Valve Knob

(5) Recoil Starter – Used to start the engine

(6) Throttle – Controls the engine speed.

(7) Choke Lever – Used to start the engine.

(8) Air Cleaner – Protects the engine by filtering dust and debris from the intake air.

(9) Garden Hose Connection

(10) High Pressure Hose Connection

(11) Detergent Tank

(12) Oil Filler Cap – Check and fill engine oil level.

(13) Gun Assembly – Gun and High Pressure Lance for power washing.

Controls and Features

Parts Included

Your 76552 Gasoline Powered Pressure Washer ships with the following parts:

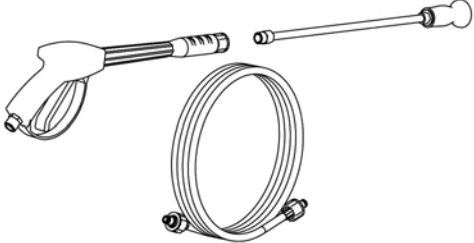

- Gun Assembly 1 piece
- Pressure Gun 1 piece
- Lance 1 piece
- Hose 1 piece



- Detergent Hose 1 piece

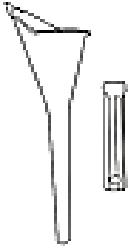

- Oil Funnel 1 piece
- Spark Plug Socket 1 piece

Assembly

Assembly

Your pressure washer requires some assembly. This unit ships from our factory without oil. It must be properly serviced with fuel and oil before operation.

If you have any questions regarding the assembly of your pressure washer, call our help line at 1-877-338-0999. Please have your serial number and model number available.

Remove the Pressure Washer from the Shipping Carton

1. Set the shipping carton on a solid, flat surface.
2. Remove everything from the carton except the pressure washer.
3. Carefully cut each corner of the box from top to bottom.

Add Engine Oil

CAUTION

DO NOT attempt to crank or start the engine before it has been properly filled with the recommended type and amount of oil. Damage to the pressure washer as a result of failure to follow these instructions will void your warranty.

1. Place the pressure washer on a flat, level surface.
2. Remove oil fill cap/dipstick to add oil.
3. Add 0.63 qt (0.6 L) of oil and replace oil fill cap/dipstick.
4. Check engine oil level daily and add as needed.

CAUTION

The engine is equipped with a low-oil-shutoff and will stop when the oil level in the crankcase falls below the threshold level.

NOTE

Check oil often during the break-in period. Refer to the Maintenance section for recommended service intervals.

Add Fuel

1. Use clean, fresh, regular unleaded fuel with a minimum octane rating of 85.
2. DO NOT mix oil with fuel.
3. Clean the area around the fuel cap.
4. Remove the fuel cap
5. Slowly add fuel to the tank. DO NOT overfill. Allow approximately ¼ inch of space for fuel expansion.
6. Screw on the fuel cap and wipe away any spilled fuel.

CAUTION

Use regular unleaded gasoline with a minimum octane rating of 85.

DO NOT mix oil and gasoline.
Fill tank to approximately ¼" below the top of the tank to allow for fuel expansion.
DO NOT fill fuel tank indoors.
DO NOT fill fuel tank when the engine is running or hot.
DO NOT overfill the fuel tank.
DO NOT light cigarettes or smoke when filling the fuel tank.

Install the Hoses

Attach the Pressure Gun

1. Attach the lance with nozzle to the gun.
2. Connect the high pressure hose to the outlet connection on the pump.
3. Connect the other end of the high pressure hose to the gun.

Connect to Garden Hose

Secure a garden hose (not included) to the inlet connection on the pump.

Operation

Pressure Washer Location

This pressure washer must have at least five feet of clearance from combustible material. Leave at least three feet of clearance on all sides of the pressure washer to allow for adequate cooling, maintenance and servicing.

Place the pressure washer in a well-ventilated area. DO NOT place the pressure washer near vents or intakes where exhaust fumes could be drawn into occupied or confined spaces. Carefully consider wind and air currents when positioning pressure washer.

Before Starting the Engine

1. Turn the water ON.
2. Pull the trigger on the pressure gun to purge all air from the pump and hose. This may take several minutes.
3. Do not start the engine until a steady stream of water is flowing from the nozzle.

Starting the Engine

1. Make certain the pressure washer is on a flat, level surface.
2. Rotate the fuel valve to the "ON" position (to the left). See image below



3. Move the choke lever (Item A) to the "Choke" position (to the left).

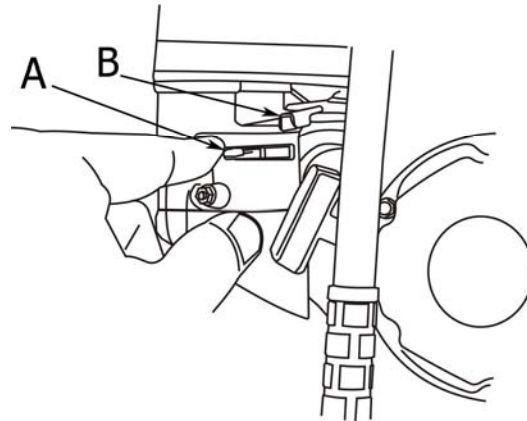

4. Pull the starter cord slowly until resistance is felt and then pull rapidly.
5. As engine warms up, move the choke lever to "Run" (to the right).
6. Move the throttle lever (Item B) to the "Fast" position.

NOTE

If the engine does not start after 2 pulls, relieve pump pressure by pulling the trigger on the pressure washer gun.

NOTE

If the engine starts but does not run make certain that the pressure washer is on a flat, level surface. The engine is equipped with a low oil sensor that will prevent the engine from running when the oil level falls below a critical threshold.

High Pressure Wash

CAUTION

Always engage the trigger safety latch when the unit is not in use.

The trigger safety latch prevents the gun from being triggered accidentally. Push the latch fully down to engage it.

Your unit is equipped with a quick connect nozzle port. Choose the appropriate nozzle tip for the job you are performing.

CAUTION

The narrow high impact spray can damage some surfaces.

Operation

A wide fan pattern distributes the impact of the water over a larger area resulting in excellent cleaning action with reduced risk of surface damage. Clean large surface areas quickly using a wide fan pattern.

Distance from Cleaning Surface

The distance between the spray nozzle and the cleaning surface is another factor that affects the impact force of the water. The impact force of the water increases as the nozzle is moved closer to the surface. You can vary the impact force by controlling

1. The nozzle's fan pattern,
2. The nozzle's angle to the cleaning surface,
3. The nozzle's distance from the cleaning surface.

Never use a narrow high impact stream on a surface that is susceptible to damage. Avoid spraying windows with a narrow high impact stream or turbo nozzle. Doing so may break the glass.

1. Before triggering the gun, select a nozzle with a wide fan pattern.
2. Place the nozzle approximately 4-5 feet away from the cleaning surface. Then hold the nozzle at a 45 degree angle to the cleaning surface. Trigger the gun.
3. Vary the fan pattern spray angle and the distance to the cleaning surface until optimum cleaning efficiency is achieved without damaging the surface.

Low Pressure Wash

Detergent Use

The use of detergents can dramatically reduce cleaning time and assist in the removal of difficult stains. Many detergents are customized for pressure washer use on specific cleaning tasks. Pressure washer detergents are as thick as water. Using thicker detergents – like dish soap – will clog the chemical injection system



NOTE

Use only detergents specially formulated for pressure washers.

You can effectively clean surfaces by combining the chemical action of detergents with high pressure rinses. On vertical surfaces, apply the detergent starting at the

bottom and work your way upward. This method prevents the detergent from sliding down and causing streaks. Begin high pressure rinsing at the bottom and work your way upward. On particularly tough stains, use a brush in combination with detergents and high pressure rinsing.

System Flush

After using detergents, flush the suction system by placing the detergent suction tube into a bucket of clean water.



WARNING

NEVER turn the water supply off before turning the engine/motor off.

Depressurize System

To depressurize, turn engine/motor off, turn water supply off and squeeze gun trigger 2-3 times.



WARNING

NEVER disconnect the high pressure discharge hose from the machine while the system is pressurized.

To reduce the risk of bodily injury or property damage, always follow this procedure whenever spraying is stopped, when work is completed, and before checking or repairing any part of the system.

1. Engage the trigger safety latch.
2. Turn the unit off.
3. Remove the ignition cable from the spark plug.
4. Shut off the water supply.
5. Disengage the trigger safety latch and trigger the gun to relieve pressure.
6. Re-engage the trigger safety latch.
7. Before overnight storage, long term storage, or transporting unit, disconnect the water supply and turn off the fuel supply valve.

Operating Tips

CAUTION

Never operate your pressure washer without water.

CAUTION

Never connect your pressure washer to a hot water supply.

Connecting your pressure washer to a hot water source will significantly reduce the life of the pump and will void your warranty.

CAUTION

Running the unit for more than one minute without spraying water causes heat to build up in the pump.

In the event that the pump gets too hot, a thermal relief valve will open to release the hot water.

Running the unit without spraying water can damage pump components and will void your warranty.

Stopping the Engine

1. Press the engine switch to the "Off" position.
2. Rotate the fuel valve to the "Off" position.
3. Depressurize system.
4. Turn off and unplug all hoses. Never start or stop the pressure washer unless the water supply is turned on.

Maintenance

Maintenance

The owner/operator is responsible for all periodic maintenance.

WARNING

Never operate a damaged or defective pressure washer.

WARNING

Improper maintenance will void your warranty.

NOTICE

Maintenance, replacement, or repair of emission control devices and systems may be performed by any non-road engine repair establishment or individual.

Complete all scheduled maintenance in a timely manner. Correct any issue before operating the pressure washer.

NOTE

For service or parts assistance, contact our help line at 1-877-338-0999.

Engine Maintenance

To prevent accidental starting, remove and ground spark plug wire before performing any service.

Oil

Change oil when the engine is warm. Refer to the oil specification to select the proper grade of oil for your operating environment.

1. Remove the oil drain plug with a 12 mm socket and extension.
2. Allow the oil to drain completely.
3. Replace the drain plug.
4. Remove oil fill cap/dipstick to add oil.

5. Add 0.63 qt (0.6 L) of oil and replace oil fill cap/dipstick.
6. Dispose of used oil at an approved waste management facility.

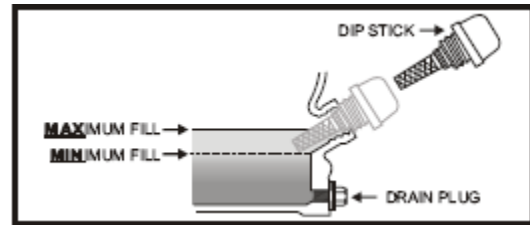

Spark Plugs

1. Remove the spark plug cable from the spark plug.
2. Use the spark plug tool that shipped with your pressure washer to remove the plug.
3. Inspect the electrode on the plug. It must be clean and not worn to produce the spark required for ignition.
4. Make certain the spark plug gap is 0.7 - 0.8mm (0.028 - 0.031 in.).
5. Refer to the spark plug recommendation chart when replacing the plug.
6. Carefully thread the plug into the engine.
7. Use the spark plug tool to firmly install the plug.
8. Attach the spark plug wire to the plug.

Air Filter

1. Unscrew wing nut to remove the air filter cover.
2. Remove the air filter.
3. Separate the foam element and the paper element.
4. Tap the paper filter element to remove dirt and debris. Use compressed air (25 PSI) to clear debris.
5. For the foam element: Wash in liquid detergent and water. Squeeze thoroughly dry in a clean cloth.
6. Saturate in clean engine oil.
7. Squeeze in a clean, absorbent cloth to remove all excess oil.
8. Reassemble the two elements and reattach.
9. Reattach the air filter cover and tighten wing nut.

Cleaning

CAUTION

DO NOT spray engine with water.

Water can contaminate the fuel system.

Use a damp cloth to clean exterior surfaces of the engine.

Use a soft bristle brush to remove dirt and oil.

Use an air compressor (25 PSI) to clear dirt and debris from the engine.

Adjustments

CPE recommends that you contact our service line at 1-877-338-0999 for all other service and/or adjustment needs.

Maintenance Schedule

Follow the service intervals indicated in the schedule below.

Service your pressure washer more frequently when operating in adverse conditions.

Contact our help line at 1-877-338-0999 to locate the nearest Champion Power Equipment certified service dealer for your maintenance needs.

Every 8 hours or daily
Check oil level
Clean around air intake and muffler
First 5 Hours
Change oil
Every 50 hours or every season
Clean air filter
Change oil if operating under heavy load or in hot environments
Every 100 hours or every season
Change oil
Clean/Adjust spark plug
Check/Adjust valve clearance *
Clean fuel tank and filter *
Every 3 years
Replace fuel line

* To be performed by knowledgeable, experienced owners or Champion Power Equipment certified service dealers

Pressure Washer Maintenance

Make certain that the pressure washer is kept clean and stored properly. Only operate the unit on a flat, level surface in a clean, dry operating environment. DO NOT expose the unit to extreme conditions, excessive dust, dirt, moisture or corrosive vapors.

CAUTION

DO NOT use a garden hose to clean the pressure washer.

Use a damp cloth to clean exterior surfaces of the pressure washer.

Use a soft bristle brush to remove dirt and oil.

Use an air compressor (25 PSI) to clear dirt and debris from the pressure washer.

Inspect all air vents and cooling slots to ensure that they are clean and unobstructed.

Cleaning Spray Nozzle

Detach the wand from the spray gun. Flush the wand with water and use a small wire rod (paper clip) to loosen up any particles.

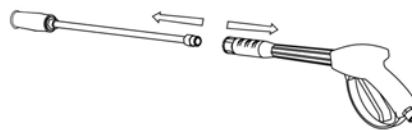

Storage

Storage

For long term storage, please follow these guidelines.

Engine Storage

1. Allow the engine to cool completely before storage.
2. Clean the engine according to the instructions in the Maintenance section.
3. Drain all fuel completely from the fuel line and carburetor to prevent gum from forming.
4. Add a fuel stabilizer into the fuel tank.
5. Change the oil.
6. Remove the spark plug and pour about $\frac{1}{2}$ ounce of oil into the cylinder. Crank the engine slowly to distribute the oil and lubricate the cylinder.
7. Reattach the spark plug.

Pressure Washer Storage

1. Allow the pressure washer to cool completely before storage.
2. Turn off the fuel supply at the fuel valve.
3. Clean the pressure washer according to the instructions in the Maintenance section.
4. Store the unit in a clean, dry area out of direct sunlight.

Winter Storage

Protect your pressure washer parts from freezing.

1. Apply all storage instructions from previous sections.
2. Make sure pressure washer hose is free of all water before storing for winter.
3. In order to prevent the pump from freezing you will need to insert RV antifreeze.
4. You will need approximately 6 ounces of RV Antifreeze, a funnel, and approximately 12" of garden hose or equivalent. See diagram below.

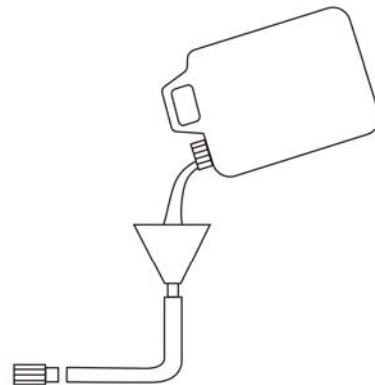

5. Pour the antifreeze into the funnel, then pull on the engine recoil starter to create suction in the pump housing. Pull the recoil several times until antifreeze comes out of the pump outlet.

Specifications

Engine Specifications

Engine 196 cc OHV CPE

Pressure Washer Specifications

Max Pressure	3000 PSI
Flow Capacity	2.5 GPM
Fuel Capacity	0.93 gallons (3.5 L)
Weight	72.6 lbs. (33 kg)
Height	34.2 inches (86.8 cm)
Width	20.1 inches (51.1 cm)
Length	29.8 inches (75.8 cm)

Fuel

Fuel capacity is 0.93 gallons (3.5 L). Use regular unleaded gasoline with a minimum octane rating of 85.

Oil

Oil capacity is 0.63 qt (0.6 L).

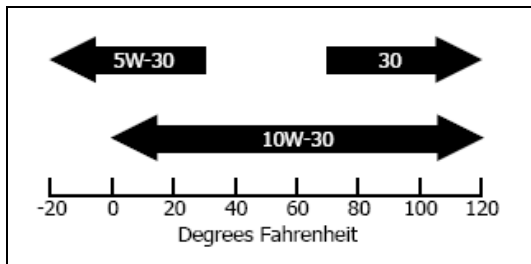

Spark Plugs

Your pressure washer comes equipped with a 3/4" (19 mm) long reach plug.

Intermittent use (less than 1 hour/month) or colder temperatures (below 60°F)
NGK BR6ES or equivalent

Moderate use (less than 3 hours/month) or seasonal temperatures (50-80°F)
NGK BR7ES or equivalent

Extreme use (continuous) or hot climates (80-100°F)
NGK BR8ES or equivalent

Make certain the spark plug gap is 0.7 - 0.8mm (0.028 - 0.031 in.).

Valve Clearance

Intake 0.13-0.17mm (0.005 – 0.007 in.)
Exhaust 0.18-0.22mm (0.007 – 0.009 in.)

Specifications

Pressure Washer Parts Diagram

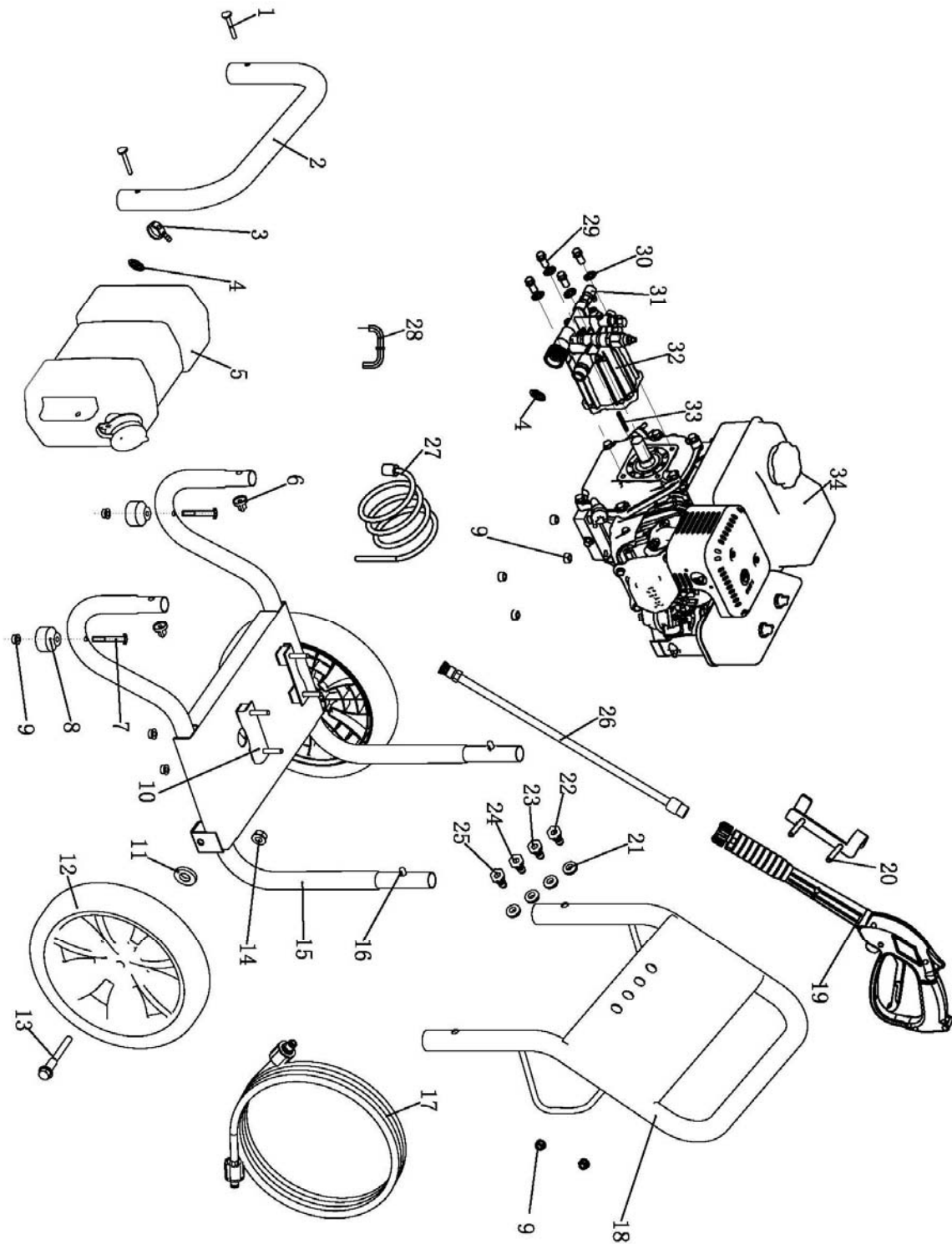

Pressure Washer Parts List

No	Part Number	Description	Qty
1	08.006045.10	Bolt M6×45	2
2	819.200701.03	Handle	1
3	819.250201.00	Tank Drain Fitting	1
4	ST29QXG-3300200	Inlet filter gasket	2
5	819.250200.00	Soap Tank	1
6	ST168F-1090100-C	Plastic Wing Nut	2
7	08.008052.10	Bolt M8×52	2
8	816.201400.00	Rubber Foot	2
9	GB6177 M8	Nut M8	12
10	ST29QXG-2100200	Engine Isolator	2
11	GB96 10	Washer 10	2
12	13.012000.01	12in Wheel	2
13	08.010082.10	Bolt M10×82	2
14	GB6182 M10	Nut M10	2
15	819.201100.00	Frame	1
16	ST29QXG-2100003	Spring Pin	2
17	819.250100.00	High Pressure Hose	1
18	819.200701.04	Handle	1
19	822.252100.00	Gun	1
20	819.200012.02	Gun Holder	1
21	ST22QXP-2100003	Nozzle Grommet	4
22	819.252300.04	Nozzle - 15 degree spray	1
23	819.252300.05	Nozzle - 25 degree spray	1
24	819.252300.06	Nozzle- 40 degree spray	1
25	819.252300.03	Nozzle - soap	1
26	819.252200.00	Wand	1
27	822.250100.00	Soap Hose, Accessory	1
28	819.250100.01	Soap Hose, Tank	1
29	ST29QXG-2000001	Bolt 5/16-24 D22	4
30	GB93 8	Lock Washer, φ8	4
31	ST30QXG-3300300	Thermal Relief Valve	1
32	819.251000.01	Pump	1
33	ST29QXG-2000006	Key SQ 3/16×1.57	1
34	ST168F-II-1000000-G6	Engine (Q), 196 cc	1

Engine Parts Diagram

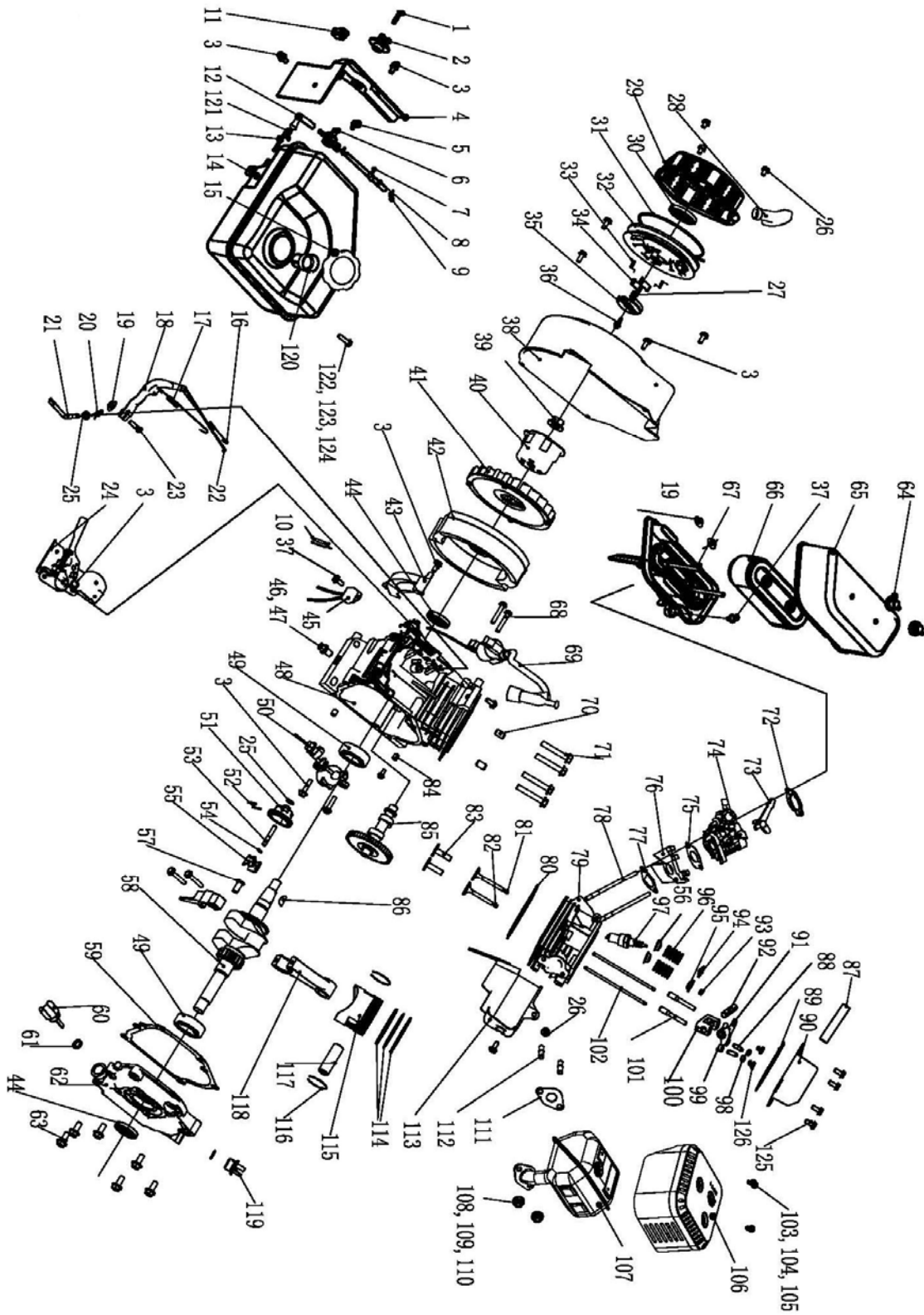

Engine Parts List

No.	Part Number	Description	Qty
1	GB818-88-B4-12	Bolt M4X12	1
2	ST168F-1070003-G	Fuel valve knob	1
3	GB16674-1-FB6-12	Flange bolt M6*12	11
4	ST168F-1070002-G	Fuel tank veil	1
5	GB5787--86-FB5-12	Flange bolt M5*12	1
6	ST168F-1070200-G	Fuel valve	1
7	ST168F-1070008-G	Tube clip φ9.5	1
8	ST168F-1070004-G	Tube 1	1
9	ST188FD--1070006A	Clipφ8	3
10	168.120700.00	Wire flame out	1
11	21.001000.00	Switch	1
12	ST168F-1070005-G	Tube 2	1
13	ST152FD-1070200	Fuel filter	1
14	168.071000.32	Fuel tank comp	1
15	ST160F--1070100H	Fuel tank cap comp	1
16	ST168F--1110005	Throttle return spring	1
17	ST168F--1110007	Governor spring	1
18	ST160F--1110003	Governor arm	1
19	GB6177--86-N6	Nut M6	3
20	ST160F--1110008	Lock pin	1
21	ST160F--1110001	Governor arm shaft	1
22	ST168F--1110006	Governor rod	1
23	ST160F--1110004	Governor arm bolt	1
24	ST168F--1111000	Control assembly	1
25	ST160F--1110108	Governor washer	2
26	GB5789--86-FB6-8	Flange bolt M6*8	5
27	ST188F-1060004	Ratchet guide spring	1
28	ST160F--1061200	Recoil starter knob	1
29	ST160F--1061100-Q	Recoil starter cover	1
30	ST160F--1061005	Recoil starter spring	1
31	ST160F--1061009	Recoil starter rope	1
32	ST160F--1061001-A	Recoil starter reel	1
33	ST188F-1060006	Ratchet spring	2
34	ST188F-1060005	Starter ratchet	2
35	ST188F-1060003	Ratchet guide	1
36	ST188F-1060002	Setting screw	1
37	GB5789--86-FB6-20	Flange bolt M6*20	4
38	ST168F--1080100-G	Fan cover comp	1
39	ST160F--1050010	Nut M14	1
40	ST160F--1060001	Start hub	1
41	ST168F--1080001	Cooling fan	1
42	ST168F--1120100	Fly wheel	1
43	ST168F--1080200	Side place	1
44	ST168F--1030100	Oil seal	2
45	ST160F-1126000	Diode comp	1
46	ST160F--1030003	Drain plug bolt	2
47	ST160F--1030004	Drain bolt washer	2
48	ST168F-2-1030012-G	Crankcase	1
49	GB/T-276-94	Radial ball bearing 6205	2
50	ST160F-1127000-A	Oil level switch assembly	1
51	ST160F--1110101	Governor weight holder	1

Specifications

No.	Part Number	Description	Qty
52	ST160F--1110102	Governor weight pin	2
53	ST160F--1110104	Governor shaft	1
54	ST160F--1110103	Governor holder clip	1
55	ST160F--1110107	Governor weight	2
56	ST168F-1040014	Valve Oil seal	2
57	ST160F--1110105-A	Governor cover	1
58	ST168F-2-1050001-Q	Crankshaft comp	1
59	ST168F--1030008-G	Case over packing	1
60	ST160F--1030001-B	Oil filler cap assembly	1
61	ST160F--1030002	Oil filler cap packing	2
62	ST168F-1030007-5/16-G	Crankcase cover	1
63	GB5789--86-FB8-32	Flange bolt 8*32	6
64	ST168F-1090100	Air cleaner cover nut	2
65	ST168F-1090001-G	Air cleaner cover	1
66	ST168F-1090200-C	Air cleaner element	1
67	ST168F-1090500-G	Air cleaner elbow comp	1
68	GB5789--86-FB6-25	Flange bolt 6*25	2
69	ST160F-1123000-G	Ignition	1
70	152FMD--1001007	Dowel pin 10*16	2
71	GB5789--86-FB8-55	Flange bolt 8*55	4
72	ST160F--1130004	Carburetor washer	1
73	ST160F--1130100	Choke level comp	1
74	ST168F-2-1130000-G	Carburetor assembly	1
75	ST160F--1130003-CPE	Carburetor packing	1
76	ST168F--1130001	Carburetor insulator	1
77	ST168F--1130002-CPE	Insulator packing	1
78	ST160F--1010001	Stud bolt 6*110	2
79	ST168F-2-1010100-G	Cylinder head comp	1
80	ST168F-2-1030009-G	Cylinder head gasket	1
81	ST168F--1040002	Intake valve	1
82	ST168F--1040006	Exhaust valve	1
83	ST168F-2-1040013	Valve lifter	2
84	ST168F-1030015-G	Dowel pin 9*14	2
85	ST168F-2-1041000	Camshaft assembly	1
86	4X7.5X19-GB1099-79	Key	1
87	ST160F--1020001	Breather tube	1
88	ST168F--1040024	Rectify bolt	2
89	ST160F--1020002-A	Head over packing	1
90	ST168F--1020100-C	Head over comp	1
91	ST168F--1040022	Entrance rocker	1
92	ST168F--1040021	Rocker axes	1
93	ST160F--1040008	Valve rotator	1
94	ST160F--1040001	Intake valve spring retainer	1
95	ST160F--1040007	Exhaust valve spring retainer	1
96	ST160F--1040003	Valve spring	2
97	ST160F--1124000	Spark plug	1
98	ST168F--1040025	Locknut	2
99	ST168F--1040023	Exhaust rocker	1
100	ST168F--1040026	Valve rocker arm	1
101	ST168F--1040027	Pivot bolt	2
102	ST168F--1040005	Push rod	2
103	GB16674.1-FB5-8	Flange bolt M5*8	4
104	GB848-85-W5	Washer φ5	4
105	GB859-87-SW5	Spring washer φ5	4

Specifications

No.	Part Number	Description	Qty
106	ST160F--1101100-G	Muffler protector	1
107	ST160F--1101200-G	Muffler comp	1
108	GB6170--86-N8	Nut M8	2
109	GB848-85-W8	washer $\phi 8$	2
110	GB859-87-SW8	Spring washer $\phi 8$	2
111	ST168F-1100200-G	Muffler packing	1
112	ST160F-1010002	Stud bolt	2
113	ST168F--1080002-G	Shroud comp	1
114	ST168F-1050007	First ring set	1
	ST168F-1050006	Second ring set	1
	ST168F-1050200	Oil ring comp	1
115	ST168F-II-1050005	Piston	1
116	ST168F--1050004	Piston pin clip	2
117	ST168F--1050003	Piston pin	1
118	ST168F--1050100	Connecting rod comp	1
119	ST160F--1030005-B	Oil filler cap	1
120	ST160F-1070006	Fuel filter	1
121	ST1P68F-1070006-F	Clip	1
122	GB848-85-W6	Washer $\phi 6$	6
123	GB859-87-SW6	Spring washer $\phi 6$	4
124	GB5789--86-FB6-35	Flange bolt M6*35	1
125	GB5789--86-FB6-15	Flange bolt M6*15	4
126	GB6187-86-N6	Lock nutM6	2

Troubleshooting

Troubleshooting

Problem	Cause	Solution
Pressure washer will not start	No fuel	Add fuel
	Faulty spark plug	Replace spark plug
Pressure washer will not start; Pressure washer starts but runs roughly	Low oil level	Fill crankcase to the proper level Place pressure washer on a flat, level surface
	Choke in the wrong position.	Adjust choke.
	Spark plug wire loose	Attach wire to spark plug
Pressure washer shuts down during operation	Out of fuel	Fill fuel tank
	Pressure washer not level	Place pressure washer on a flat, level surface
	Low oil level	Fill crankcase to the proper level. Place pressure washer on a flat, level surface
Pressure washer gallops	Engine governor defective	Contact the help line
Unit does not reach high pressure	Water supply is restricted	Check hoses for leaks, blockage, kinks
	Garden hose is too small	Replace with 5/8 in. garden hose or larger
	Garden hose inlet filter is clogged	Remove garden hose, clean filter and rinse out
	Not enough inlet water	Turn garden hose water on full force
Spray pressure varies from high to low	Poor inlet water supply	Turn garden hose water on full force. Check hose for leaks, blockage, or kinks
	Garden hose inlet filter is clogged	Remove garden hose, clean filter and rinse out
	Spray nozzle is obstructed	Remove particles with small wire rod (see maintenance section in manual)
	Pump is sucking air	Check all hoses and fittings, make sure they are securely tightened down and fastened. Turn off engine and purge pump by squeezing trigger gun until a steady stream of water flows
Detergent wash is not functioning properly	Detergent is too thick	Dilute detergent
	Wand is on high pressure setting	Detergent only works on a low pressure setting
	Detergent hose is not connected to the pump housing	Check connection. See diagram on Page 9
	Spray nozzle is obstructed	Clean nozzle and remove debris
	Filter on detergent hose is clogged	Clean with warm water or replace
Garden hose connection leaks	Loose fittings	Tighten
	Missing/worn-out rubber washer	Replace rubber washer
Spray wand leaks	Spray wand not properly attached	Tighten all connections

Warranty

CHAMPION POWER EQUIPMENT 1 YEAR LIMITED WARRANTY

Effective September 1, 2006. Replaces all undated warranties and all warranties dated before September 1, 2006.

Warranty Qualifications

Champion Power Equipment (CPE) will register this warranty upon receipt of your Warranty Registration Card and a copy of your sales receipt from one of CPE's retail locations as proof of purchase.

Please submit your warranty registration and your proof of purchase within ten (10) days of the date of purchase.

Repair/Replacement Warranty

CPE warrants to the original purchaser that the mechanical and electrical components will be free of defects in material and workmanship for a period of one (1) year from the original date of purchase (90 days for commercial & industrial use). Transportation charges on product submitted for repair or replacement under this warranty are the sole responsibility of the purchaser. This warranty only applies to the original purchaser and is not transferable.

Do not return the unit to the place of purchase

Contact CPE's Technical Service and CPE will troubleshoot any issue via phone or e-mail. If the problem is not corrected by this method, CPE will, at its option, authorize evaluation, repair or replacement of the defective part or component at a CPE Service Center. CPE will provide you with a case number for warranty service. Please keep it for future reference. Repairs or replacements without prior authorization, or at an unauthorized repair facility, will not be covered by this warranty.

Warranty Exclusions

This warranty does not cover the following repairs and equipment:

Normal Wear

Pressure washers need periodic parts and service to perform well. This warranty does not cover repair when normal use has exhausted the life of a part or the equipment as a whole.

Installation, Use and Maintenance

This warranty will not apply to parts and/or labor if this pressure washer is deemed to have been misused, neglected, involved in an accident, abused, loaded beyond the pressure washer's limits, modified, installed improperly or connected incorrectly to any water supply. Normal maintenance such as spark plugs, air filters, adjustments, fuel system cleaning and obstruction due to buildup is not covered by this warranty.

Other Exclusions

This warranty excludes:

Cosmetic defects such as paint, decals, etc.
Wear items such as filter elements, o-rings, etc.
Accessory parts such as starting batteries, and storage covers.

Failures due to acts of God and other force majeure events beyond the manufacturer's control.

Problems caused by parts that are not original Champion Power Equipment parts.

Limits of Implied Warranty and Consequential Damage

Champion Power Equipment disclaims any obligation to cover any loss of time, use of this product, freight, or any incidental or consequential claim by anyone from using this pressure washer. THIS WARRANTY IS IN LIEU OF ALL OTHER WARRANTIES, EXPRESS OR IMPLIED, INCLUDING WARRANTIES OF MERCHANTABILITY OR FITNESS FOR A PARTICULAR PURPOSE

A unit provided as an exchange will be subject to the warranty of the original unit. The length of the warranty governing the exchanged unit will remain calculated by reference to the purchase date of the original unit.

This warranty gives you certain legal rights which may change from state to state. Your state may also have other rights you may be entitled to that are not listed within this warranty.

Contact Information

Address

Champion Power Equipment, Inc.
Customer Service
10006 Santa Fe Springs Rd.
Santa Fe Springs, CA 90670

Customer Service

Mon – Fri 8:30 AM – 5:00 PM (PST/PDT)
Toll Free: 1-877-338-0999
Fax no.: 1-562-236-9429

Technical Service

Mon – Fri 8:30 AM – 5:00 PM (PST/PDT)
Toll Free: 1-877-338-0999
tech@championpowerequipment.com

**Champion Power Equipment, Inc (CPE),
Emission Control System Warranty**

Your Champion Power Equipment (CPE) engine complies with Environment Canada (EC) emission regulations.

YOUR WARRANTY RIGHTS AND OBLIGATIONS:

CPE is pleased to explain the Emission Control Systems Warranty on your 2012 small off-road engine. New engines must be designed, built and equipped, at the time of sale, to meet EC regulations for small non-road engines. CPE must warrant the emission control system on your small off-road engine for the period of time listed below, provided there has been no abuse, neglect, unapproved modification, or improper maintenance of your small off-road engine.

Your emission control system may include parts such as the carburetor, fuel-injection system, the ignition system, catalytic converter and fuel lines. Also included may be hoses, belts, connectors and other emission related assemblies. Where a warrantable condition exists, CPE will repair your small off-road engine at no cost to you including diagnosis, parts and labor.

MANUFACTURER'S EMISSION CONTROL SYSTEM WARRANTY COVERAGE:

This emission control system is warranted for two years, subject to provisions set forth below. If, during the warranty period, emission related part on your engine is defective in materials or workmanship, the part will be repaired or replaced by CPE.

OWNER WARRANTY RESPONSIBILITIES:

As the small off-road engine owner, you are responsible for the performance of the required maintenance listed in your Owner's Manual. CPE recommends that you retain all your receipts covering maintenance on your small off-road engine, but CPE cannot deny warranty solely for the lack of receipts or for your failure to ensure the performance of all scheduled maintenance.

As the small off-road engine owner, you should however be aware that CPE may deny you warranty coverage if your small, off-road engine or a part has failed due to abuse, neglect, improper maintenance or unapproved modifications.

You are responsible for presenting your small off-road engine to an Authorized CPE service outlet, CPE dealer or CPE, Santa Fe Springs, CA., USA as soon as a problem exists. The warranty repairs should be completed in a reasonable amount of time, not to exceed 30 days.

If you have any questions regarding your warranty rights and responsibilities, you should contact:

Champion Power Equipment, Inc.
Customer Service
10006 Santa Fe Springs Road
Santa Fe Springs, CA 90670
USA
Tel: 1-877-338-0999

The emission warranty is a defects warranty. Defects are judged on normal engine performance. The warranty is not related to an in-use emission test.

EMISSION CONTROL SYSTEM WARRANTY

The following are specific provisions relative to your Emission Control System Warranty Coverage.

Emission Control System Warranty (ECS Warranty):

1. APPLICABILITY: The ECS Warranty Period shall begin on the date the new engine or equipment is delivered to its original, end-use purchaser, and shall continue for 24 consecutive months thereafter.

2. GENERAL EMISSIONS WARRANTY COVERAGE

CPE warrants to the original, end-use purchaser of the new engine or equipment and to each subsequent purchaser that each of its small off-road engines is:

a. Designed, built and equipped so as to conform at the time of sale with applicable regulations under the Canadian Environmental Protection Act, 1999 (CEPA 1999).

b. Free from defects in materials and workmanship that cause the failure of a warranted part to be identical in all material respects to the part as described in the engine manufacturer's application for certification for a period of two years.

3. THE WARRANTY ON EMISSION-RELATED PARTS WILL BE INTERPRETED AS FOLLOWS:

a. Any warranted part that is not scheduled for replacement as required maintenance in the Owners Manual shall be warranted for the ECS Warranty Period. If any such part fails during the ECS Warranty Period, it shall be repaired or replaced by CPE according to Subsection "d" below. Any such part repaired or replaced under the ECS Warranty shall be warranted for any remainder of the ECS Warranty Period.

b. Any warranted, emissions-related part which is scheduled only for regular inspection as specified in the Owners Manual shall be warranted for the ECS Warranty Period. A statement in such written instructions to the effect of "repair or replace as necessary", shall not reduce the ECS Warranty Period. Any such part repaired or replaced under the ECS Warranty shall be warranted for the remainder of the ECS Warranty Period.

c. Any warranted, emissions-related part which is scheduled for replacement as required maintenance in the Owner's Manual shall be warranted for the period of time prior to the first scheduled replacement point for that part. If the part fails prior to the first scheduled replacement, the part shall be repaired or replaced by CPE according to Subsection "d" below. Any such emissions-related part repaired or replaced under the ECS Warranty, shall be warranted for the remainder of the ECS Warranty Period prior to the first scheduled replacement point for such emissions-related part.

d. Repair or replacement of any warranted, emissions-related part under this ECS Warranty shall be performed at no charge to the owner at a CPE Authorized Service Outlet.

e. The owner shall not be charged for diagnostic labor which leads to the determination that a part covered by the ECS Warranty is in fact defective, provided that such diagnostic work is performed at a CPE Authorized Service Outlet.

f. CPE shall be liable for damages to other original engine components or approved modifications proximately caused by a failure under warranty of an emission-related part covered by the ECS Warranty.

g. Throughout the ECS Warranty Period, CPE shall maintain a supply of warranted emission-related parts sufficient to meet the expected demand for such emission-related parts.

h. Any CPE Authorized and approved emission-related replacement part may be used in the performance of any ECS Warranty maintenance or repair and will be provided without charge to the owner. Such use shall not reduce CPE's warranty obligation.

i. Unapproved add-on or modified parts may not be used to modify or repair a CPE engine. Such use voids this ECS Warranty and shall be sufficient grounds for disallowing an ECS Warranty claim. CPE shall not be liable hereunder for failures of any warranted parts of a CPE engine caused by the use of such an unapproved add-on or modified part.

EMISSION-RELATED PARTS INCLUDE THE FOLLOWING: (using those portions of the list applicable to the engine)

Systems covered by this warranty	Parts Description
Fuel Metering System	Fuel regulator, Carburetor and internal parts
Air Induction System	Air cleaner, Intake manifold
Ignition System	Spark plug and parts, Magneto ignition system
Exhaust System	Exhaust manifold, catalytic converter
Miscellaneous Parts	Tubing, Fittings, Seals, Gaskets, and Clamps associated with these listed systems.

TO OBTAIN WARRANTY SERVICE:

You must take your CPE engine or the product on which it is installed, along with your warranty registration card or other proof of original purchase date, at your expense, to any Champion Power Equipment dealer who is authorized by Champion Power Equipment, Inc. to sell and service that CPE product during his normal business hours. Claims for repair or adjustment found to be caused solely by defects in material or workmanship will not be denied because the engine was not properly maintained and used.

If you have any questions regarding your warranty rights and responsibilities, or to obtain warranty service, please write or call Customer Service at Champion Power Equipment, Inc.

**Champion Power Equipment, Inc.
10006 Santa Fe Springs Road
Santa Fe Springs, CA 90670
USA
1-877-338-0999
Attn: Customer Service**