

CHAMPION

GLOBAL POWER EQUIPMENT™

OWNER'S MANUAL & OPERATING INSTRUCTIONS



6000 Starting Watts / 5000 Running Watts
Electric Start

PORTABLE GENERATOR



MODEL NUMBER

71330

SAVE THESE INSTRUCTIONS
Important Safety Instructions
are included in this manual.

MADE IN CHINA
REV 71330-20130330

10006 Santa Fe Springs Road
Santa Fe Springs CA 90670
USA / 1-877-338-0999
www.championpowerequipment.com

AN IMPORTANT MESSAGE ABOUT TEMPERATURE:

Your Champion Power Equipment product is designed and rated for continuous operation at ambient temperatures up to 40°C (104°F). When your product is needed your product may be operated at temperatures ranging from -15°C (5°F) to 50°C (122°F) for short periods. If the product is exposed to temperatures outside this range during storage, it should be brought back within this range before operation. In any event, the product must always be operated outdoors, in a well-ventilated area and away from doors, windows and other vents.

Have questions or need assistance?

Do not return this product to the store!

WE ARE HERE TO HELP!

Visit our website:

www.championpowerequipment.com

for more info:

- Product Info & Updates
- Tech Bulletins
- Frequently Asked Questions
- Product Registration

– or –

Call our Customer Care Team Toll-Free at:

1-877-338-0999

WARNING:

The Engine Exhaust from this product contains chemicals known to the State of California to cause cancer, birth defects or other reproductive harm.

*We are always working to improve our products. Therefore, the enclosed product may differ slightly from the image on the cover.

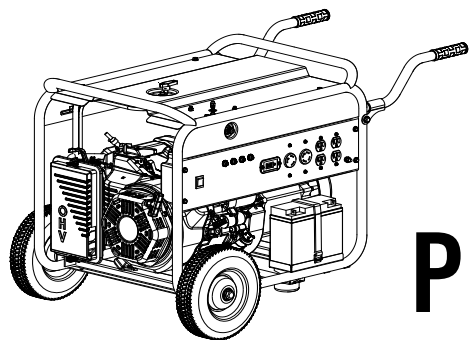

6000 Starting Watts / 5000 Running Watts
Electric Start

PORTABLE GENERATOR

TABLE OF CONTENTS

Introduction	1	Storage	16
Introduction	1	Generator Storage	16
Portable Power Generator	1	Battery	16
Accessories	1	Charge the Battery	16
This Booklet	1	Disconnect the Battery	16
Manual Conventions	2	Specifications	17
Safety Rules	3	Engine Specifications	17
Controls and Features	5	Generator Specifications	17
Generator	5	Fuel	17
Power Panel	6	Oil	17
Parts Included	7	Spark Plugs	17
Wheel Kit	7	Maintenance Valve Clearance	17
Other	7	An Important Message About Temperature	17
Assembly	8	Wiring Diagram	18
Remove the Generator from the Shipping Carton	8	Parts Diagram	19
Install the Wheel Kit	8	Parts List	20
Install the Support Leg	8	Engine Parts Diagram	21
Install the Handles	8	Engine Parts List	22
Connect the Battery	8	Troubleshooting	23
Add Engine Oil	9	Warranty	24
Connecting Liquid Petroleum Gas (LPG)		Warranty Qualifications	24
Cylinder	10	Repair/Replacement Warranty	24
Grounding	10	Do Not Return The Unit To	
Operation	11	The Place Of Purchase	24
Generator Location	11	Warranty Exclusions	24
Grounding	11	Normal Wear	24
Surge Protection	11	Installation, Use and Maintenance	24
Starting the Engine	11	Other Exclusions	24
Connecting Electrical Loads	12	Limits of Implied Warranty	
Stopping the Engine	13	and Consequential Damage	24
Operation at High Altitude	13	Contact Information	24
Do Not Overload Generator	13	Address	24
Capacity	13	Customer Service	24
Power Management	13	Technical Service	24
Maintenance and Storage	14		
Engine Maintenance	14		
Oil	14		
Spark Plugs	14		
Air Filter	14		
Spark Arrester	15		
Cleaning	15		
Adjustments	15		
Maintenance Schedule	15		
Generator Maintenance	15		

INTRODUCTION

Introduction

Congratulations on your purchase of a Champion Power Equipment generator. CPE designs and builds generators to strict specifications. With proper use and maintenance, this generator will bring years of satisfying service.

Portable Power Generator

This unit is a liquid petroleum gas (LPG) engine driven, alternating current (AC) generator. It is designed to supply electrical power for lighting, appliances, tools and similar equipment.

Accessories

Champion Power Equipment manufactures and sells accessories designed to help you get the most from your purchase. To find out more about our covers, power cables, please visit our web site at:

→ www.championpowerequipment.com

This Booklet

Every effort has been made to ensure the accuracy and completeness of the information in this manual. We reserve the right to change, alter and/or improve the product and this document at any time without prior notice.

Record the model and serial numbers as well as date and place of purchase for future reference. Have this information available when ordering parts and when making technical or warranty inquiries.

Champion Power Equipment Support
1-877-338-0999
Model Number
71330
Serial Number
Date of Purchase
Purchase Location
For Oil Type see 'Add Engine Oil' section. For Fuel Type see 'Fuel' section.

This manual uses the following symbols to help differentiate between different kinds of information. The safety symbol is used with a key word to alert you to potential hazards in operating and owning power equipment.

Follow all safety messages to avoid or reduce the risk of serious injury or death.

 **DANGER**

DANGER indicates an imminently hazardous situation which, if not avoided, **will** result in death or serious injury.

 **WARNING**

WARNING indicates a potentially hazardous situation which, if not avoided, **could** result in death or serious injury.

 **CAUTION**

CAUTION indicates a potentially hazardous situation which, if not avoided, **may** result in minor or moderate injury.

CAUTION

CAUTION used without the safety alert symbol indicates a potentially hazardous situation which, if not avoided, **may** result in property damage.

 **NOTE**

If you have questions regarding your generator, we can help. Please call our help line at **1-877-338-0999**.

SAFETY RULES

WARNING

Read this manual thoroughly before operating your generator. Failure to follow instructions could result in serious injury or death.

WARNING

The engine exhaust from this product contains chemicals known to the state of California to cause cancer, birth defects, or other reproductive harm.

DANGER

Generator exhaust contains carbon monoxide, a colorless, odorless, poison gas. Breathing carbon monoxide will cause nausea, dizziness, fainting or death. If you start to feel dizzy or weak, get to fresh air immediately.

Operate generator outdoors only in a well ventilated area.

DO NOT operate the generator inside any building, including garages, basements, crawlspaces and sheds, enclosure or compartment, including the generator compartment of a recreational vehicle. DO NOT allow exhaust fumes to enter a confined area through windows, doors, vents or other openings.

DANGER CARBON MONOXIDE: using a generator indoors **CAN KILL YOU IN MINUTES.**

DANGER

Rotating parts can entangle hands, feet, hair, clothing and/or accessories.
Traumatic amputation or severe laceration can result.

Keep hands and feet away from rotating parts.
Tie up long hair and remove jewelry.
Operate equipment with guards in place.
DO NOT wear loose-fitting clothing, dangling drawstrings or items that could become caught.

DANGER

Generator produces powerful voltage.

DO NOT touch bare wires or receptacles.
DO NOT use electrical cords that are worn, damaged or frayed.
DO NOT operate generator in wet weather.
DO NOT allow children or unqualified persons to operate or service the generator
Use a ground fault circuit interrupter (GFCI) in damp areas and areas containing conductive material such as metal decking.
Use approved transfer equipment to isolate generator from your electric utility and Notify your utility company before connecting your generator to your power system.

WARNING

Sparks can result in fire or electrical shock.

When servicing the generator:

Disconnect the spark plug wire and place it where it cannot contact the plug.
DO NOT check for spark with the plug removed.
Use only approved spark plug testers.

WARNING

Running engines produce heat. Severe burns can occur on contact.
Combustible material can catch fire on contact.

DO NOT touch hot surfaces.
Avoid contact with hot exhaust gases.
Allow equipment to cool before touching.
Maintain at least three feet of clearance on all sides to ensure adequate cooling.
Maintain at least five feet of clearance from combustible materials.

WARNING

Medical and Life Support Uses.

In case of emergency, call 911 immediately.
NEVER use this product to power life support devices or life support appliances.
NEVER use this product to power medical devices or medical appliances.
Inform your electricity provider immediately if you or anyone in your household depends on electrical equipment to live.
Inform your electrical provider immediately if a loss of power would cause you or anyone in your household to experience a medical emergency.

⚠ DANGER**LIQUID PETROLEUM GAS (LPG) IS HIGHLY FLAMMABLE AND EXPLOSIVE.**

Fire or explosion can cause severe burns or death. Unintentional startup can result in entanglement, traumatic amputation or laceration.

Liquefied Petroleum Gas (LPG):

- LPG IS HIGHLY FLAMMABLE AND EXPLOSIVE.
- Flammable gas under pressure can cause a fire or explosion if ignited.
- LPG is heavier than air and can settle in low places while dissipating.
- LPG has a distinctive odor added to help detect potential leaks quickly.
- In any petroleum gas fire, flames should not be extinguished unless by doing so the fuel supply valve can be turned OFF. This is because if a fire is extinguished and a supply of fuel is not turned OFF, then an explosion hazard could be created.
- When exchanging LPG cylinders, be sure the cylinder valve is of the same type.
- Always keep the LPG cylinder in an upright position.

When starting the generator:

DO NOT attempt to start a damaged generator. Make certain that the gas supply, air filter, spark plug, fuel lines and exhaust system are properly in place. Make certain that the generator is resting firmly on level ground.

When operating the generator:

DO NOT move or tip the generator during operation. DO NOT tip the generator or allow oil to spill.

When transporting or servicing the generator:

Make certain that the fuel shutoff valve is in the off position and the LPG cylinder is not attached. Disconnect the spark plug wire.

When storing the generator:

Store away from sparks, open flames, pilot lights, heat and other sources of ignition.

⚠ WARNING

Rapid retraction of the starter cord will pull hand and arm towards the engine faster than you can let go. Unintentional startup can result in entanglement, traumatic amputation or laceration. Broken bones, fractures, bruises or sprains could result.

When starting engine, pull the starter cord slowly until resistance is felt and then pull rapidly to avoid kickback. DO NOT start or stop the engine with electrical devices plugged in.

⚠ CAUTION

Exceeding the generator's running capacity can damage the generator and/or electrical devices connected to it.

DO NOT overload the generator. Start the generator and allow the engine to stabilize before connecting electrical loads. Connect electrical equipment in the off position, and then turn them on for operation. Turn electrical equipment off and disconnect before stopping the generator. DO NOT tamper with the governed speed. DO NOT modify the generator in any way.

⚠ CAUTION

Improper treatment or use of the generator can damage it, shorten its life and void your warranty.

Use the generator only for intended uses. Operate only on level surfaces. DO NOT expose generator to excessive moisture, dust, or dirt. DO NOT allow any material to block the cooling slots. If connected devices overheat, turn them off and disconnect them from the generator. DO NOT use the generator if:

- Electrical output is lost
- Equipment sparks, smokes or emits flames
- Equipment vibrates excessively

⚠ WARNING

Operation of this equipment may create sparks that can start fires around dry vegetation.

A spark arrestor may be required. The operator should contact local fire agencies for laws or regulations relating to fire prevention requirements.

CONTROLS AND FEATURES

Read this owner's manual before operating your generator. Familiarize yourself with the location and function of the controls and features. Save this manual for future reference.

Generator

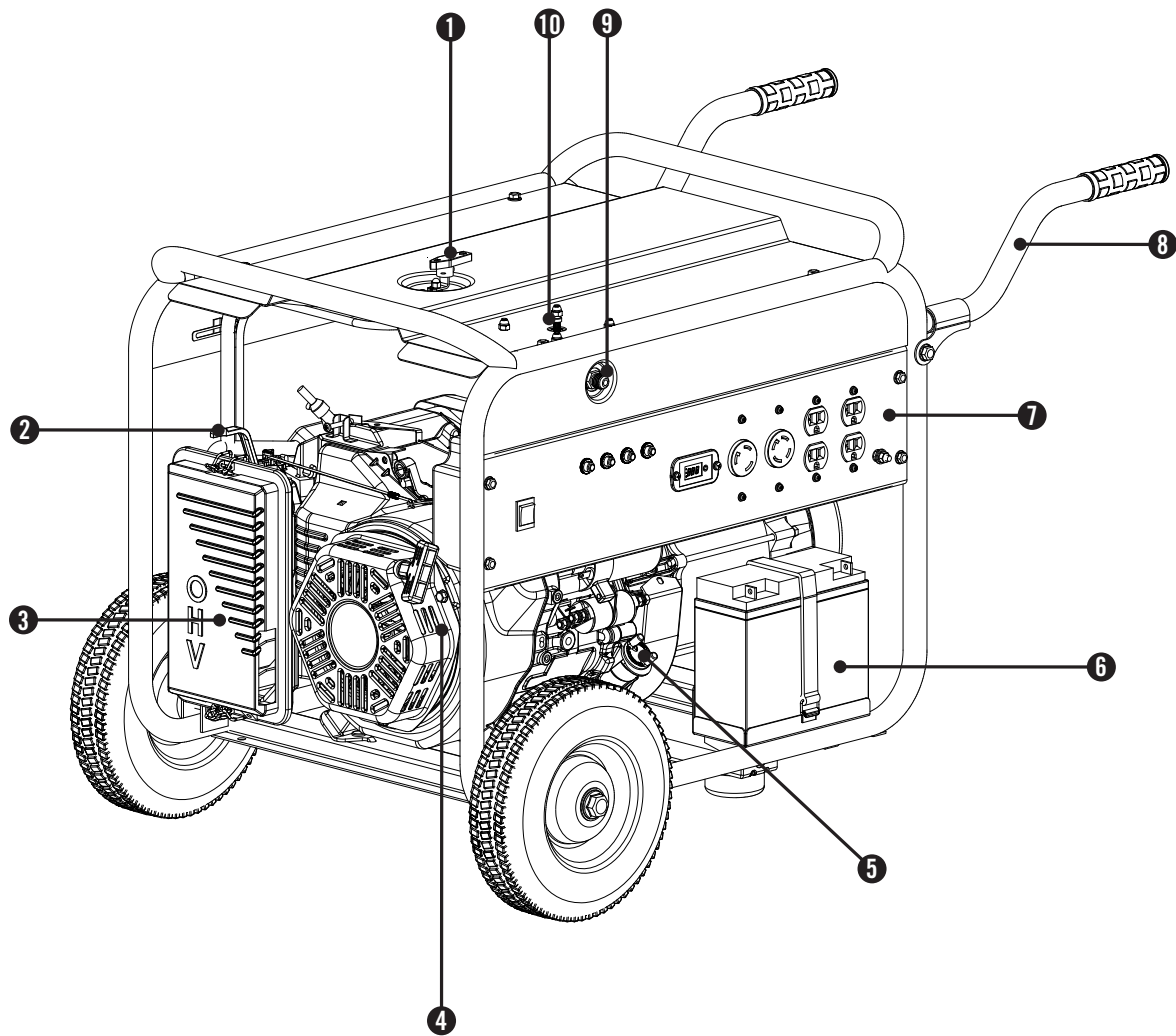

- | | |
|---|---|
| (1) Fuel Valve – Used to turn fuel supply on and off to engine. | (6) Battery – Used to start the engine. Provides 12V DC to the electric starter and receiver control module. |
| (2) Choke – Used to start the engine. | (7) Power Panel – See “Power Panel” section. |
| (3) Air Filter – Protects the engine by filtering dust and debris from the intake air. | (8) Handle |
| (4) Recoil Starter – Used to manually start the engine. | (9) LPG Hose Connector |
| (5) Oil Filler Cap – Check and fill engine oil level. | (10) Primer Button |

Power Panel

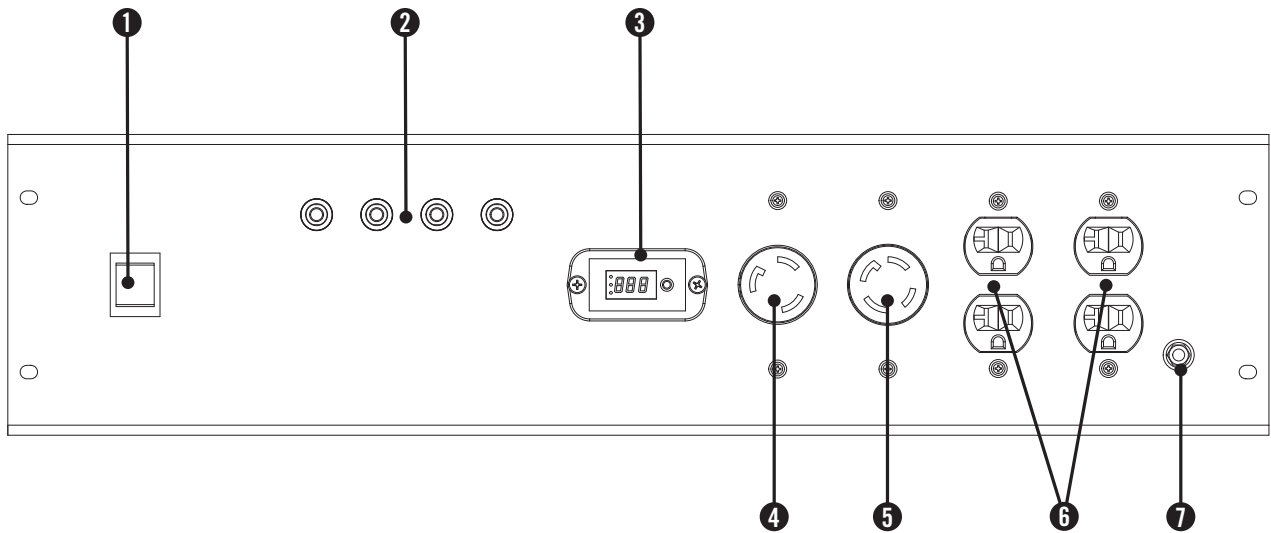

- (1) **Ignition Switch** – Used to start or stop the generator.
- (2) **Circuit Breakers** – Protects the generator against electrical overloads. Push to reset breaker.
- (3) **Intelligauge™** – Three mode digital meter for displaying running hours, voltage and hertz.
- (4) **120 Volt AC, 30 Amp Twist-Lock Receptacle (NEMA L5-30R)** – May be used to supply electrical power for the operation of 120 Volt AC, 30 Amp, single phase 60 Hz electrical loads.
- (5) **120/240 Volt AC, 30 Amp Twist-Lock Receptacle (NEMA L14-30R)** – May be used to supply electrical power for the operation of 120 and/or 240 Volt AC, 30 Amp, single phase 60 Hz electrical loads.
- (6) **120 Volt AC, 20 Amp Duplex (2)** (NEMA 5-20R) – May be used to supply electrical power for the operation of 120 Volt AC, 20 Amp, single phase 60 Hz electrical loads.
- (7) **Ground Terminal** – Consult an electrician for local grounding regulations.

CONTROLS AND FEATURES

Parts Included

Your 71330 LPG Powered Generator ships with the following parts:

Wheel Kit

– 10 in. Wheel	2
– Flange Bolt (M10x115 for Wheel)	2
– Bushing	2
– Flat Washer 10	2
– Nut (M10)	2
– Support Leg w/Vibration Mounts	1
– Flange Bolt (M8x16 for Support Leg)	2
– Nut (M8 for Support Leg)	2
– Handle	2
– Flange Bolt (M8x45 for Handle)	2
– Nylon Washers (for Handle)	4
– Nut (M8 for Handle)	2

Other

– 5 ft. LPG Hose	1
– Oil	1.16 qt. (1.1 L)
– Oil Funnel	1
– Spark Plug Socket	1
– Cap Screw (M5x10 for Battery Terminals)	2
– Nut (M5)	2

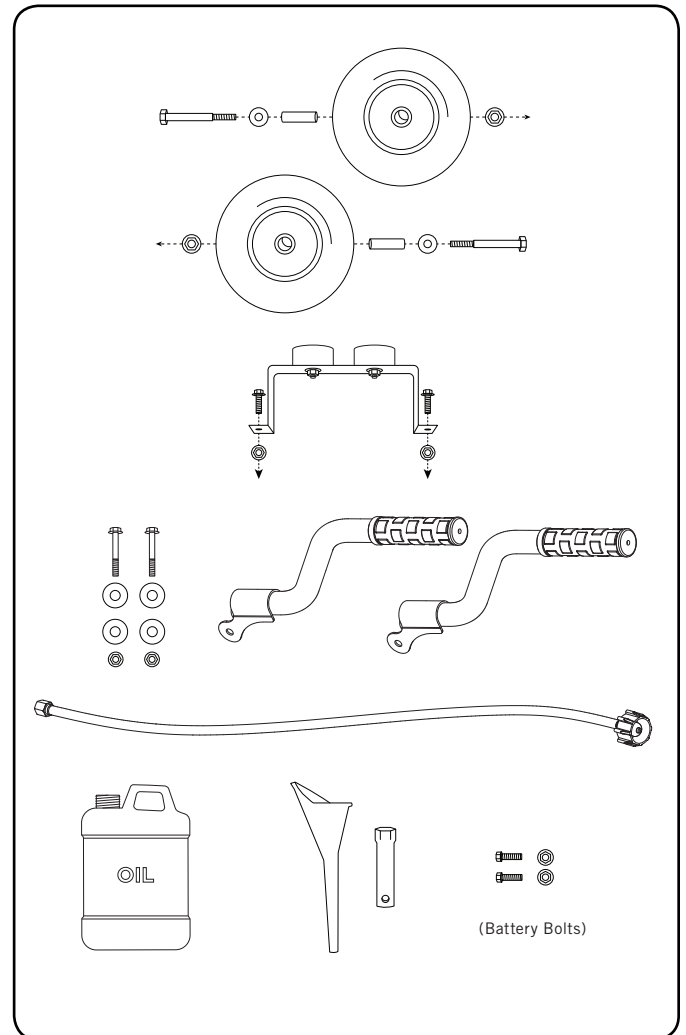

Your generator requires some assembly. This unit ships from our factory without oil. It must be properly serviced with fuel and oil before operation.

If you have any questions regarding the assembly of your generator, call our help line at 1-877-338-0999. Please have your serial number and model number available.

Remove the Generator from the Shipping Carton

1. Set the shipping carton on a solid, flat surface.
2. Remove everything from the carton except the generator.
3. Carefully cut each corner of the box from top to bottom. Fold each side flat on the ground to provide a surface area to install the wheel kit and support leg.

Install the Wheel Kit

! CAUTION

The wheel kit is not intended for over-the-road use.

You will need the following tools to install the wheels:

- 17 mm wrench OR adjustable wrench (not included)
- Socket wrench with a 16 mm socket (not included)
- Pliers (not included)

1. Before connecting fuel and adding oil, tip the generator on it's side.
2. Slide the M10x115 wheel bolt through the washer, sleeve and wheel.
3. Slide the bolt through the mount point on the frame.
4. Fasten securely with the M10 nut.
5. Repeat steps 2-4 to attach the second wheel.

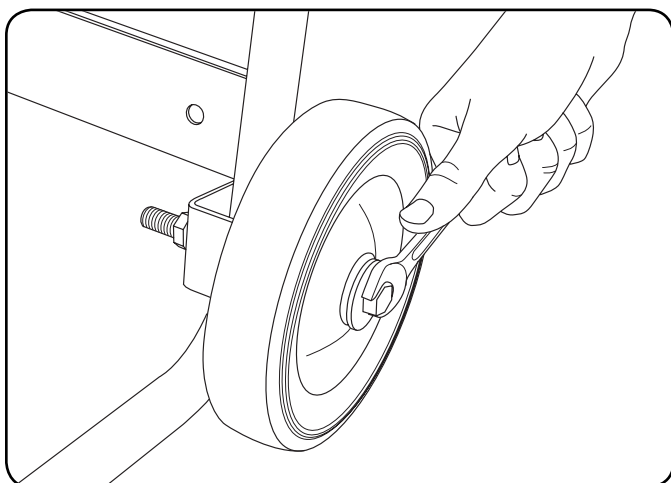

Install the Support Leg

1. Attach the support leg to the generator frame with cap screws (M8x16) and nuts (M8).
2. Tip the generator slowly so that it rests on the wheels and support leg.

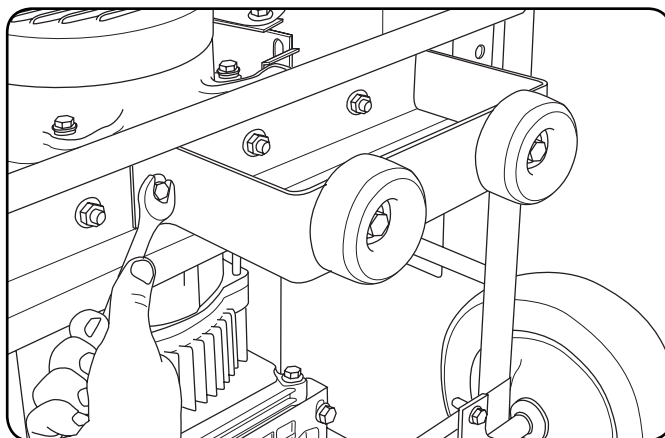

Install the Handles

1. Line up the holes on the handle with the holes on the frame.
2. Thread nylon washer through M8x45 flange bolt.
3. Insert bolt through handle and frame.
4. Thread nylon washer onto bolt after it is through the handle and frame.
5. Secure with M8 nut. Tighten. DO NOT over tighten.
6. Repeat steps 1-5 for second handle.

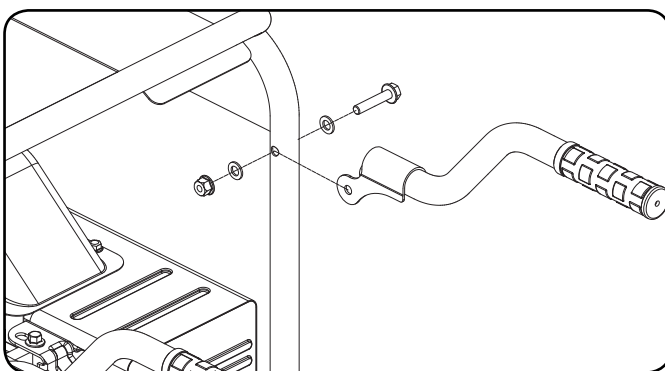

Connect the Battery

1. Remove the protective cover from the red (+) lead on the battery.
2. Attach the red (+) lead to the red (+) terminal on the battery with the cap screw (M5x10) and secure with the lock washer (M5).
3. Repeat steps 1-2 for the black (-) battery lead.

ASSEMBLY

Add Engine Oil

! CAUTION

DO NOT attempt to crank or start the engine before it has been properly filled with the recommended type and amount of oil. Damage to the generator as a result of failure to follow these instructions will void your warranty.

NOTE

The recommended oil type is 10W-30 automotive oil.

1. Place the generator on a flat, level surface.

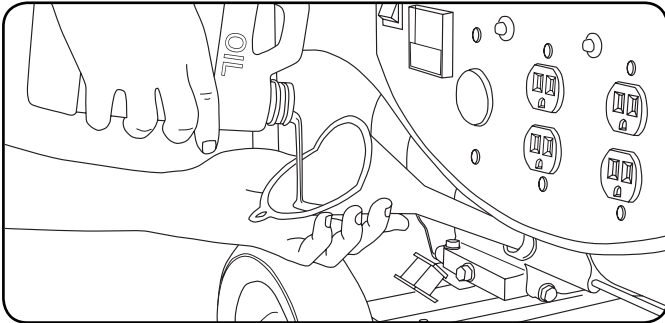

2. Remove oil fill cap/dipstick to add oil.
3. Add up to 1.16 qt. (1.1 L) of oil and replace oil fill cap/dipstick. DO NOT OVERFILL.

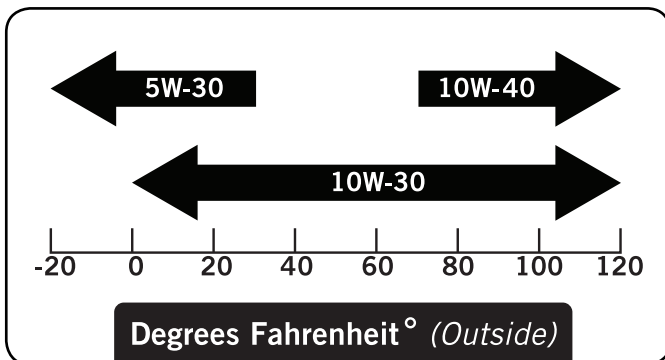

4. Check engine oil level daily and add as needed.

Add Engine Oil Cont'd.

CAUTION

The engine is equipped with a low oil shut-off and will stop when the oil level in the crankcase falls below the threshold level.

NOTE

Check oil often during the break-in period. Refer to the Maintenance section for recommended service intervals.

NOTE

The generator rotor has a sealed, pre-lubricated ball bearing that requires no additional lubrication for the life of the bearing.

Connecting Liquid Petroleum Gas (LPG) Cylinder

1. Make sure the fuel valve on the generator is in the off position.
2. Attach the LPG hose (included) to the LPG hose connector on the side of the generator and tighten with a 19 mm or adjustable wrench. (A)
Important: DO NOT use tape or any other type of sealant to seal LPG hose connection.
3. Remove the safety plug or cap from the cylinder valve.
4. Attach the other end of the hose to the LPG connector on the cylinder and hand tighten.

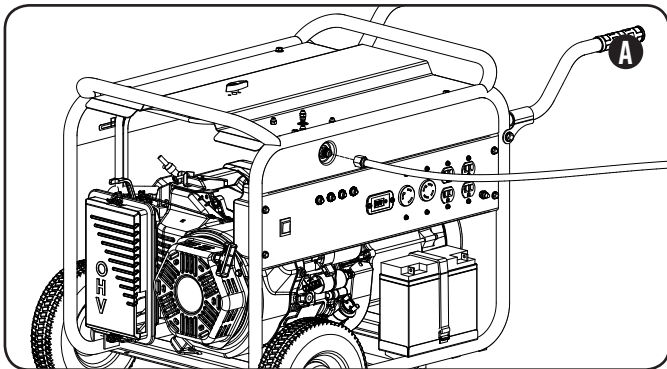

NOTE

- Use only standard 20 or 30 pound capacity LP tanks with Type 1, right hand Acme threads.
- Verify the requalification date on the tank has not expired.
- All new cylinders must be purged of air and moisture prior to filling. Used cylinders that have not been plugged or kept closed must also be purged.
- The purging process should be done by a LPG supplier. (Cylinders from an exchange supplier should have been purged and filled properly already).
- Always position the cylinder so the connection between the valve and the gas inlet won't cause sharp bends or kinks in the hose.

CAUTION

Do not allow children to tamper or play with the cylinder or hose connections.

Connecting LPG Cylinder Cont'd.

! CAUTION

Use approved LPG cylinders equipped with an OPD (overfilling prevention device) valve. Always keep the cylinder in a vertical position with the valve on top and installed at ground level on a flat surface. Cylinders must not be installed near any heat source and should not be exposed to sun, rain, and dust. When transporting and storing, turn off the cylinder valve and fuel valve, and disconnect the cylinder. Plug the outlet, usually by a plastic protective cap, if one is available. Keep cylinders away from heat and ventilated when in a vehicle.

! WARNING

If there is a strong smell of gas: Close off the gas supply at the cylinder. Use soapy water, which will produce a large bubble at the point of any leak, to check the hose, and connections on the cylinder valve and the generator. Do not smoke or light a cigarette, or check for leaks using a match, open flame source or lighter. Contact a qualified technician to inspect and repair the LPG system if a leak is found, before using the generator.

Grounding

Your generator must be properly connected to an appropriate ground to help prevent electric shock.

! WARNING

Failure to properly ground the generator can result in electric shock.

A ground terminal connected to the frame of the generator has been provided on the power panel. For remote grounding, connect a length of heavy gauge (12 AWG minimum) copper wire between the generator ground terminal and a copper rod driven into the ground. We strongly recommend that you consult with a qualified electrician to ensure compliance with local electrical codes.

OPERATION

Generator Location

NEVER operate the generator inside any building, including garages, basements, crawlspaces and sheds, enclosure or compartment, including the generator compartment of a recreational vehicle. Please consult your local authority. In some areas, generators must be registered with the local utility. Generators used at construction sites may be subject to additional rules and regulations. Generators should be on a flat, level surface at all times. (Even while not in operation) Generators must have at least five feet of clearance from all combustible material. In addition to clearance from all combustible material, generators must also have at least three feet of clearance on all sides to allow for adequate cooling, maintenance and servicing. Generators should never be started or operated in the back of a SUV, camper, trailer, in the bed of a truck (regular, flat or otherwise), under staircases/stairwells, next to walls or buildings, or in any other location that will not allow for adequate cooling of the generator and/or the muffler. DO NOT contain generators during operation. Allow generators to properly cool before transport or storage. Place the generator in a well-ventilated area. DO NOT place the generator near vents or intakes where exhaust fumes could be drawn into occupied or confined spaces. Carefully consider wind and air currents when positioning generator.

Failure to follow proper safety precautions may void manufacturer's warranty.

WARNING

Do not operate or store the generator in rain, snow, or wet weather.

Using a generator or electrical appliance in wet conditions, such as rain or snow, or near a pool or sprinkler system, or when your hands are wet, could result in electrocution.

WARNING

During operation the muffler and exhaust fumes produced will become hot. If adequate cooling and breathing space are not supplied, or if the generator is blocked or contained, temperatures can become extremely heated and may lead to fire.

Grounding

The generator system ground connects the frame to the ground terminals on the power panel.

- The generator (stator winding) is isolated from the frame and from the AC receptacle ground pin.
- Electrical devices that require a grounded receptacle pin connection will not function if the receptacle ground pin is not functional.

Surge Protection

CAUTION

Voltage fluctuation may impair the proper functioning of sensitive electronic equipment.

Electronic devices, including computers and many programmable appliances use components that are designed to operate within a narrow voltage range and may be affected by momentary voltage fluctuations. While there is no way to prevent voltage fluctuations, you can take steps to protect sensitive electronic equipment.

1. *Install UL1449, CSA-listed, plug-in surge suppressors on the outlets feeding your sensitive equipment.* Surge suppressors come in single- or multi-outlet styles. They're designed to protect against virtually all short-duration voltage fluctuations.

Starting the Engine

1. Make certain the generator is on a flat, level surface.
2. Disconnect all electrical loads from the generator. Never start or stop the generator with electrical devices plugged in or turned on.
3. Make certain the LPG cylinder is in the upright position and on a flat, level surface.
4. Open the valve on the fuel source.
5. Open the FUEL VALVE on the generator.
6. Press and hold the PRIMER BUTTON for 1-2 seconds.
7. Move the CHOKE LEVER to CHOKE. *Only required if temp. below 40°F (4°C).
8. Flip the ignition switch to the "ON" position.
9. ELECTRIC START: Press and hold the ignition switch to the "START" position. Release as the engine begins to roll over. If the engine fails to start within five seconds, release the switch and wait at least ten seconds before attempting to start the engine again.

Starting the Engine Cont'd.

10. RECOIL START: Slowly pull the RECOIL HANDLE 2 times, then pull quickly to START the engine.
11. As engine starts, move CHOKE LEVER to RUN. *Only required if temp. below 40°F (4°C).
12. If the engine fails to start the first time, repeat steps 6-11.

NOTE

If the engine starts but does not run make certain that the generator is on a flat, level surface. The engine is equipped with a low oil sensor that will prevent the engine from running when the oil level falls below a critical threshold.

NOTE

If the temperature is below 40°F (4°C) the choke may be used during the engine warm-up cycle. The CHOKE LEVER should always set to RUN when generator has reached operating temperature and is running smoothly.

NOTE

Keep choke lever in “Choke” position for only 2 pulls of the recoil starter. After 2 pulls, move choke lever to the “Run” position for up to the next 3 pulls of the recoil starter. Too much choke leads to an over-rich condition due to the lack of incoming air. This will cause the engine not to start.

NOTE

The supplied 12V 15AH battery does re-charge while the engine is running, but it is also recommended that the battery be fully charged at least once per month.

Connecting Electrical Loads

1. Let the engine stabilize and warm up for a few minutes after starting
2. Plug in and turn on the desired 120/240 Volt AC single phase, 60 Hz electrical loads.
 - DO NOT connect 3-phase loads to the generator.
 - DO NOT connect 50 Hz loads to the generator.
 - DO NOT overload the generator.

NOTE

Connecting a generator to your electric utility company's power lines or to another power source may be against the law. In addition this action, if done incorrectly, could damage your generator and appliances and could cause serious injury or even death to you or a utility worker who may be working on nearby power lines. If you plan to run a portable electric generator during an outage, please notify your electric utility company immediately and remember to plug your appliances directly into the generator. Do not plug the generator into any electric outlet in your home. Doing so could create a connection to the utility company power lines. You are responsible for ensuring that your generator's electricity does not feed back into the electric utility power lines.

If the generator will be connected to a building electrical system, consult your local utility company or a qualified electrician. Connections must isolate generator power from utility power and must comply with all applicable laws and codes.

OPERATION

Stopping the Engine

1. Turn off and unplug all electrical loads. Never start or stop the generator with electrical devices plugged in or turned on.
2. Let the generator run at no-load for several minutes to stabilize internal temperatures of the engine and generator.
3. Close the OPD valve on the LPG cylinder.
4. Let the engine run until fuel starvation has stopped the engine. This usually takes a few seconds.
5. Turn the Fuel Valve on the generator to the "OFF" position.

Important: Always ensure that the Fuel Valve and the cylinder OPD valve are in the "OFF" position when the engine is not in use.

NOTE

If the engine will not be used for a period of two (2) weeks or longer, please see the Storage section for proper engine and fuel storage.

Operation at High Altitude

The density of air at high altitude is lower than at sea level. Engine power is reduced as the air mass and air-fuel ratio decrease. Engine power and output will be reduced approximately 3½% for every 1000 feet of elevation above sea level. This is a natural trend and cannot be changed by adjusting the engine.

Do Not Overload Generator

Capacity

Follow these simple steps to calculate the running and starting watts necessary for your purposes.

1. Select the electrical devices you plan on running at the same time.
2. Total the running watts of these items. This is the amount of power you need to keep your items running.
3. Identify the highest starting wattage of all devices identified in step 1. Add this number to the number calculated in step 2. Surge wattage is the extra burst of power needed to start some electric driven equipment. Following the steps listed under "Power Management" will guarantee that only one device will be starting at a time.

Power Management

Use the following formula to convert voltage and amperage to watts:

$$\text{Volts} \times \text{Amps} = \text{Watts}$$

To prolong the life of your generator and attached devices, follow these steps to add electrical load:

1. Start the generator with no electrical load attached
2. Allow the engine to run for several minutes to stabilize.
3. Plug in and turn on the first item. It is best to attach the item with the largest load first.
4. Allow the engine to stabilize.
5. Plug in and turn on the next item.
6. Allow the engine to stabilize.
7. Repeat steps 5-6 for each additional item.

NOTE

Never exceed the specified capacity when adding loads to the generator.

The owner/operator is responsible for all periodic maintenance.

WARNING

Never operate a damaged or defective generator.

WARNING

Tampering with the factory set governor will void your warranty.

WARNING

Improper maintenance will void your warranty.

NOTE

Maintenance, replacement, or repair of emission control devices and systems may be performed by any non-road engine repair establishment or individual.

Complete all scheduled maintenance in a timely manner. Correct any issue before operating the generator.

NOTE

For service or parts assistance, contact our help line at **1-877-338-0999**

Engine Maintenance

To prevent accidental starting, remove and ground spark plug wire before performing any service.

Oil

Change oil when the engine is warm. Refer to the oil specification to select the proper grade of oil for your operating environment.

1. Remove the oil drain plug with a 15 mm socket and extension.
2. Allow the oil to drain completely.
3. Replace the drain plug.
4. Remove oil fill cap/dipstick to add oil.
5. Add 1.16 qt (1.1 L) of oil and replace oil fill cap/dipstick. **DO NOT OVERFILL.**
6. Dispose of used oil at an approved waste management facility.

Oil Cont'd.

NOTE

Once oil has been added, a visual check should show oil about 1-2 threads from running out of the fill hole. If using the dipstick to check oil level, **DO NOT** screw in the dipstick while checking.

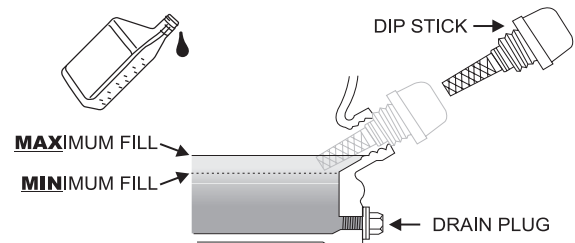

Spark Plugs

1. Remove the spark plug cable from the spark plug.
2. Use the spark plug tool that shipped with your generator to remove the plug.
3. Inspect the electrode on the plug. It must be clean and not worn to produce the spark required for ignition.
4. Make certain the spark plug gap is 0.7 - 0.8 mm or (0.028 - 0.031 in.).

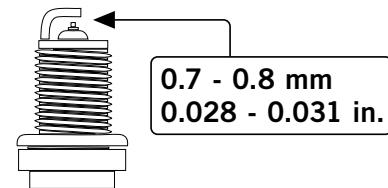

5. Refer to the spark plug recommendation chart when replacing the plug.
6. Carefully thread the plug into the engine.
7. Use the spark plug tool to firmly install the plug.
8. Attach the spark plug wire to the plug.

Air Filter

1. Remove the snap-on cover holding the air filter to the assembly.
2. Remove the foam element.
3. Wash in liquid detergent and water. Squeeze thoroughly dry in a clean cloth.
4. Saturate in clean engine oil.
5. Squeeze in a clean, absorbent cloth to remove all excess oil.
6. Place the filter in the assembly.
7. Reattach the air filter cover and snap in place.

MAINTENANCE AND STORAGE

Spark Arrester

1. Allow the engine to cool completely before servicing the spark arrester.
2. Remove the three screws holding the cover plate which retains the end of the spark arrester to the muffler.
3. Remove the spark arrester screen.
4. Carefully remove the carbon deposits from the spark arrester screen with a wire brush.
5. Replace the spark arrester if it is damaged.
6. Position the spark arrester in the muffler and attach with the three screws.

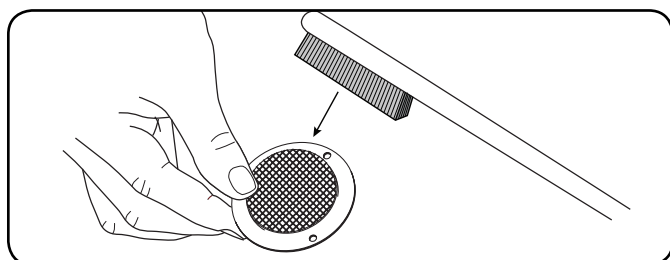

! CAUTION

Failure to clean the spark arrester will result in degraded engine performance.

NOTE

Federal and local laws and administrative requirements indicate when and where spark arresters are required. When ordered, spark arresters are required for operation of this generator in National Forest lands. In California, this generator must not be used on any forest-covered land, brush-covered land, or grass-covered land unless the engine is equipped with a spark arrester.

Cleaning

! CAUTION

DO NOT spray engine with water.

Water can contaminate the fuel system.

Use a damp cloth to clean exterior surfaces of the engine. Use a soft bristle brush to remove dirt and oil. Use an air compressor (25 PSI) to clear dirt and debris from the engine.

Adjustments

The air-fuel mixture is not adjustable. Tampering with the governor can damage your generator and your electrical devices and will void your warranty. CPE recommends that you contact our service line at **1-877-338-0999** for all other service and/or adjustment needs.

Maintenance Schedule

Follow the service intervals indicated in the following maintenance schedule.

Service your generator more frequently when operating in adverse conditions.

Contact our helpline at **1-877-338-0999** to locate the nearest Champion Power Equipment certified service dealer for your generator or engine maintenance needs.

Every 8 hours or daily	
	Check oil level
	Clean around air intake and muffler
	Check hoses for leaks
First 5 Hours	
	Change oil
Every 50 hours or every season	
	Clean air filter
	Change oil if operating under heavy load or in hot environments
Every 100 hours or every season	
	Change oil
	Clean/Adjust spark plug
	Check/Adjust valve clearance*
	Clean spark arrester

*To be performed by knowledgeable, experienced owners or Champion Power Equipment certified dealers.

Generator Maintenance

Make certain that the generator is kept clean and stored properly. Only operate the unit on a flat, level surface in a clean, dry operating environment. DO NOT expose the unit to extreme conditions, excessive dust, dirt, moisture or corrosive vapors.

! CAUTION

DO NOT use a garden hose to clean the generator.

Water can enter the generator through the cooling slots and damage the generator windings.

Use a damp cloth to clean exterior surfaces of the generator. Use a soft bristle brush to remove dirt and oil. Use an air compressor (25 PSI) to clear dirt and debris from the generator. Inspect all air vents and cooling slots to ensure that they are clean and unobstructed.

Storage

Generator Storage

1. Be sure all appliances are disconnected from the generator.
2. Start up and run the generator for a short time.
3. Turn the OPD valve on the cylinder to the "Closed" position.
4. Let the generator run until fuel starvation has stopped the engine. This usually takes a few seconds.
5. Turn the fuel valve on the generator to the "Off" position.
6. The generator needs to cool completely before cleaning and storage.
7. Disconnect the fuel hose from the LPG cylinder.
8. Clean the generator according to the maintenance section.
9. Change the oil.
10. Remove the spark plug and pour about 1/2 ounce of oil into the cylinder. Crank the engine slowly to distribute the oil and lubricate the cylinder.
11. Reattach the spark plug.
12. Store the unit in a clean, dry place out of direct sunlight.

DANGER

Generator exhaust contains odorless and colorless carbon monoxide gas.

To avoid accidental or unintended ignition of your generator during periods of storage, the following precautions should be followed:

- When **storing the generator for short or extended periods of time** make sure that the LPG cylinder is disconnected from the generator and the Fuel Valve is set in the **OFF** position.

WARNING

After a period (short or extended) of non-use we recommend that you perform the following maintenance procedures for utmost user safety:

- Check all hoses and fuel lines before each use for any holes, cracking, abrasions, nicks, cuts, or any other form of damage. If any hose or fuel line is found to be damaged in any way, **DO NOT** use the unit until the damaged part has been properly replaced.
- **DO NOT** try and repair any worn or damaged hose or fuel line, replace it with a new part **ONLY**.
- Always check for gas leaks every time a hose or fuel line is replaced, or disconnected and reconnected to any fuel fitting. This will ensure that fuel is properly flowing to the unit and eliminate possible hazards.

Generator Storage Cont'd.

NOTE

- Store LPG tank disconnected from fuel hose and generator.
- Store LPG tank with the OPD valve in the "Closed" position.
- Do not store LPG tank in or around extreme heat. LPG gas is extremely flammable.
- Do not store LPG tank in or around extreme cold. LPG gas will freeze.

WARNING

Contact with LPG from either the cylinder, excess from the hose, or from any leaks may cause freeze burns on skin. Do not touch or spill LPG on bare skin.

Battery

This product is equipped with an automatic battery charging circuit. The battery will receive charging voltage when the engine is running. The battery will maintain a proper charge if the unit is used on a regular basis (about once every two weeks). If it is used less frequently, the battery should be connected to a trickle charger or battery maintainer to keep the battery properly charged. If the battery is not able to start the engine, it can be started by manually pulling the engine recoil cord. If the battery voltage is extremely low, the charging circuit may not be able to re-charge the battery. In this case, the battery must be connected to a standard automotive style battery charger for re-charging before it can be used.

Charge the Battery

For pressure washers equipped with batteries for electric starting, proper battery maintenance and storage should be followed. An automatic battery charger with automatic trickle charging capability should be used to charge the battery. Maximum charging rate should not exceed 1.5 amps. Follow the instructions included with the battery charger. The battery should be fully charged at least once per month.

NOTE

A Float Charger will maintain the battery condition over long storage periods.

Disconnect the Battery

1. Remove the protective cover from the black/negative battery lead.
2. Disconnect the black/negative lead from the black/negative terminal on the battery and store the cap screw (M5x10) and lock washer (M5).
3. Repeat steps 1-2 for the red/positive battery lead.
4. Store the battery in a cool, dry place.

SPECIFICATIONS

Engine Specifications

- Model YF188FD-LPG-110
- Displacement 389cc
- Type 4-Stroke OHV
- Start Type Electric Start

Generator Specifications

- Model 71330
- Running Wattage 5000 Watts
- Starting Wattage 6000 Watts
- AC Load 120/240 V
- Phase Single
- Frequency 60 Hz
- Gross Weight 205 lbs (93 kg)
- Net Weight 193.6 lbs (87.8 kg)
- Height 25.5 inches (64.8 cm)
- Width 26.9 inches (68.3 cm)
- Length 32.7 inches (83 cm)

Fuel

Use only an approved LPG cylinder equipped with an OPD valve.

Oil

Use 10W-30 automotive oil.

Oil capacity is up to 1.16 qt. (1.1 L).

DO NOT OVERFILL.

Please reference the following chart for recommended oil types for use in the generator.

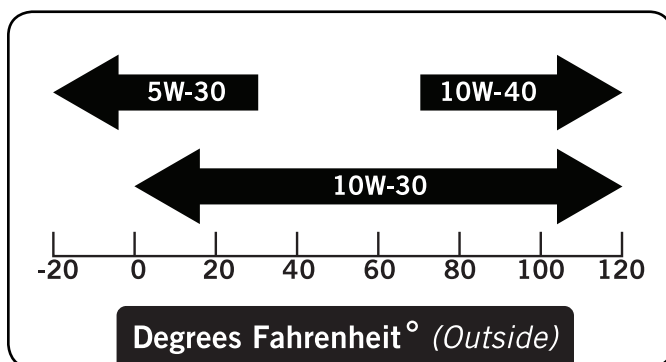

Spark Plugs

OEM spark plug: NHSP F7RTC

Replacement spark plug: NGK BPR7ES or equivalent
Make certain the spark plug gap is 0.7 - 0.8 mm or (0.028 - 0.031 in.).

Maintenance Valve Clearance

- Intake: 0.13 – 0.17 mm (0.005 – 0.007 in.)
 - Exhaust: 0.18 – 0.22 mm (0.007 – 0.009 in.)
- Note: Tech bulletin regarding the valve adjustment procedure is on www.championpowerequipment.com.

An Important Message About Temperature

Your Champion Power Equipment product is designed and rated for continuous operation at ambient temperatures up to 40°C (104°F). When your product is needed your product may be operated at temperatures ranging from -15°C (5°F) to 50°C (122°F) for short periods. If the product is exposed to temperatures outside this range during storage, it should be brought back within this range before operation. In any event, the product must always be operated outdoors, in a well-ventilated area and away from doors, windows and other vents.

Wiring Diagram

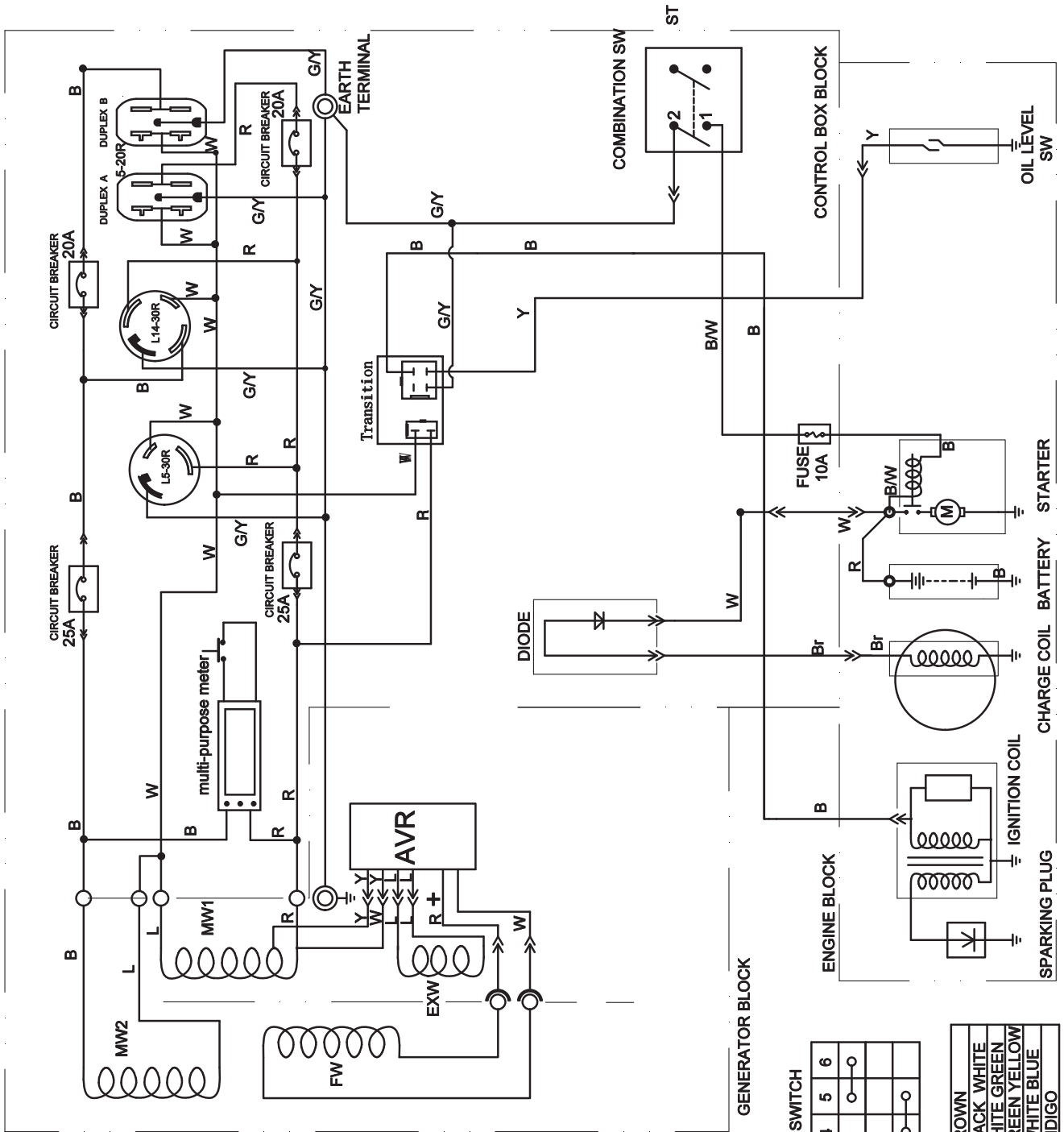

COMBINATION SWITCH

1	2	3	4	5	6
OFF		○	○	○	○
ON					
ST	○	○		○	○

B	BLACK	Br	BROWN
Y	YELLOW	B/W	BLACK WHITE
L	BLUE	W/G	WHITE GREEN
G	GREEN	G/Y	GREEN YELLOW
R	RED	W/L	WHITE BLUE
W	WHITE	In	INDIGO

SPECIFICATIONS

Parts Diagram

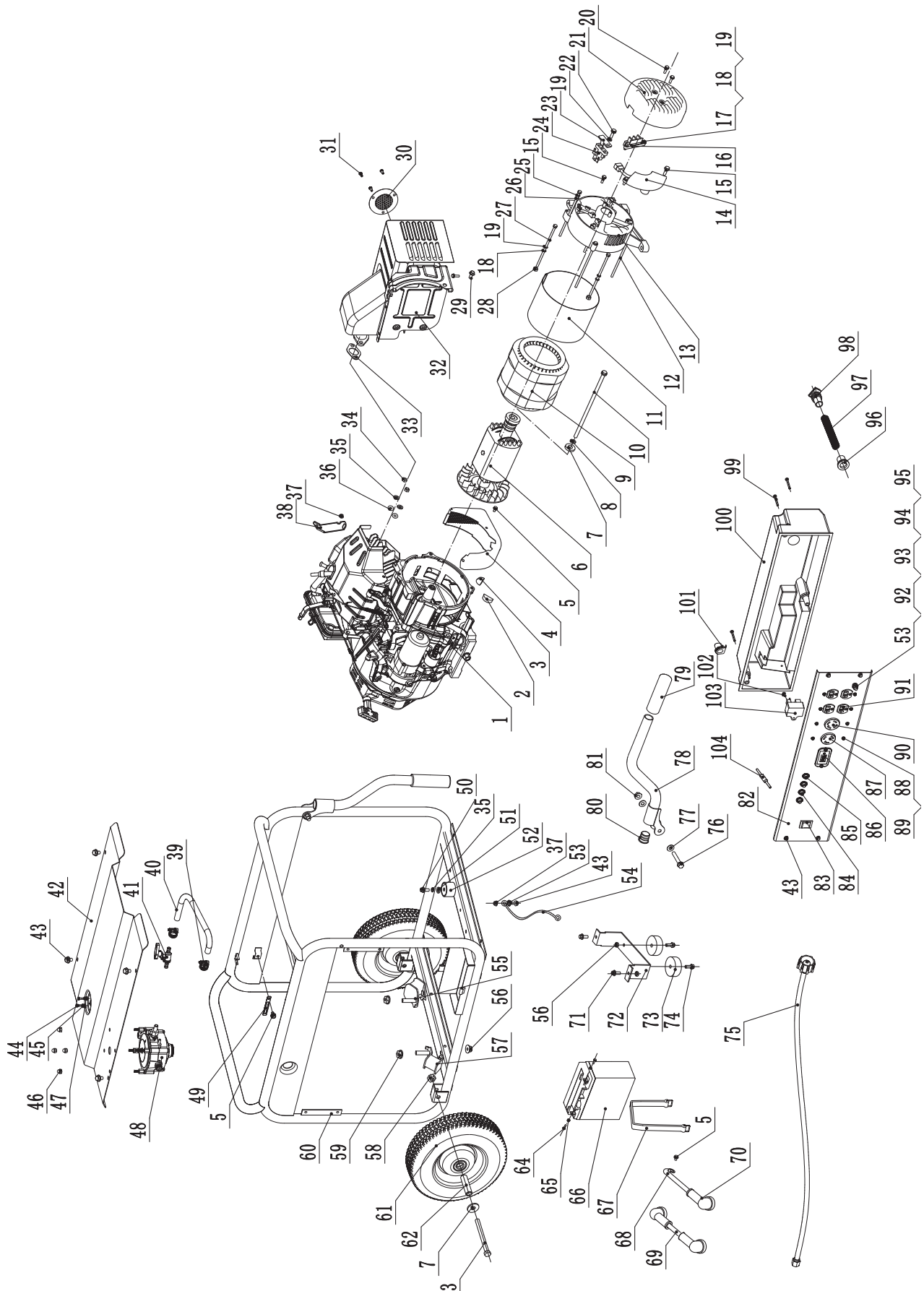

#	Part Number	Description	Qty
1	46.690	Engine	1
2	152.190005.01	Rubber,Fore-Cover	1
3	152.190005.00	Rubber,Fore-Cover	1
4	152.192300.00	Air Guide	1
5	1.5789.0608	Flange Bolt M6x8	5
6	152.191100.02	Rotor Assembly	1
7	1.96.10	Washer Ø10	3
8	1.7244.10	Spring Washer Ø10	1
9	152.191200.23	Stator Assembly	1
10	2.08.034	Flange Bolt M10x265	1
11	152.191002.00	Stator Cover	1
12	2.08.032	Flange Bolt M6x179	4
13	152.190002.00	End Housing	1
14	152.190200.04	AVR	1
15	1.16674.0516	Flange Bolt M5x16	3
16	122.190400.00	Terminal Block	1
17	1.5783.0516	Bolt M5x16	2
18	1.97.1.05	Washer Ø5	4
19	1.93.05	Spring Washer Ø5	5
20	1.16674.0512.2	Flange Bolt M5x12	2
21	152.190003.00.76	Generator End Cover	1
22	1.5783.0520	Bolt M5x20	1
23	122.190004.01	Pinch	1
24	152.190300.00	Carbon Bursh Assembly	1
25	1.93.06	Spring Washer Ø6	4
26	1.97.1.06	Washer Ø6	4
27	2.08.035	Flange Bolt M5x214	2
28	1.6175.05	Nut M5	2
29	1.16674.0820	Flange Bolt M8x20	2
30	46.101300.00	Spark Arrester Assembly	1
31	1.9074.4.0510	Combination Screw M5x10	3
32	46.101000.00.2	Muffler Assembly	1
33	46.100001.07	Muffler Gasket	1
34	1.6175.08	Nut M8	2
35	1.93.08	Spring Washer Ø8	4
36	1.848.08	Washer Ø8	2
37	1.6177.1.06	Nut M6	2
38	45.090006.20	Holder,Air Cleaner	1
39	2.06.023	Clip	2
40	26.130021.03	Tracheal (250mm)	1
41	122.074000.01	Cut-off Valve	1
42	152.070200.06.76	Plate	1
43	1.5789.0612	Flange Bolt M6x12	9
44	1.823.0408	Screw M4x8	2
45	1.93.04	Spring Washer Ø4	2
46	1.923.06	Nut M6	4
47	1.97.1.04	Washer Ø4	2
48	46.136000.03	Pressure Reducing Valve Assembly	1
49	2.05.050	Clamp,Wire	1
50	1.5789.0835	Flange Bolt M8x35	2
51	2.03.040	Big Washer Ø8	2
52	152.201200.00	Straight Bottom Rubber	2

#	Part Number	Description	Qty
53	1.862.06	Lock Washer Ø6	2
54	5.1900.026	Grounding Line	1
55	152.201200.04	Motor Mount	1
56	1.6177.1.08	Nut M8	8
57	152.201200.03	Motor Mount I	1
58	1.6182.10	Nut M10	2
59	1.6177.1.10	Nut M10	2
60	6.5.220.402.2	Frame	1
61	152.201701.04.76	10in Wheel	2
62	253.200016.00	Bush Ø10.5x69.5	2
63	1.5782.10115	Bolt M10x115	2
64	1.9074.3.0510	Combination Screw M5x10	2
65	1.6177.1.05	Nut M5	2
66	9.1000.150	Battery 12V15AH	1
67	152.200904.00	Pinch,Rubber	1
68	5.1900.014	Black Wire,Battery	1
69	5.1900.021	Red Wire,Battery	1
70	152.200013.01	Jacket	3
71	1.5789.0816	Flange Bolt M8x16	2
72	152.200002.01.2	Support Leg	1
73	152.201400.00	Vibration Mount	2
74	1.5789.0825	Flange Bolt M8x25	2
75	26.130021.04	Tracheal	1
76	1.5789.0845	Flange Bolt M8x45	2
77	2.03.011	Nylon Washers	4
78	122.200701.04.2	Handle	2
79	152.200702.00	Cover,Handle	2
80	152.201001.01	Choke Plug	2
81	1.6187.1.08	Nut M8	2
82	152.02.77.2	Control Panel	1
83	5.1000.005.3	Switch	1
84	5.1210.925	Ac.25A Breaker	2
85	5.1210.920	Ac.20A Breaker	2
86	5.1430.002	Intelligauge	1
87	5.1120.008	Receptacle L5-30R	1
88	1.9074.4.0414.1	Combination Screw M4x14	8
89	1.6177.1.04.1	Nut M4	8
90	5.1120.009	Receptacle L14-30R	1
91	5.1120.010	Receptacle 5-20R Duplex	2
92	1.93.06.3	Spring Washer Ø8	2
93	1.97.1.06.3	Washer Ø8	2
94	1.5783.0622.3	Bolt M6x22	1
95	1.6175.06.3	Nut M6	2
96	122.210003.01	Plug	1
97	5.1330.118	Sheath,Wire	1
98	152.210003.02	Plug	1
99	1.9074.1.0538.2	Combination Screw M5x38	3
100	152.210002.08	Control Box	1
101	152.210003.04	Plug	1
102	1.823.0514	Screw M5x14	1
103	5.1810.001	Over Voltage Protector	1
104	5.1800.002	Rectifier	1

SPECIFICATIONS

Engine Parts Diagram

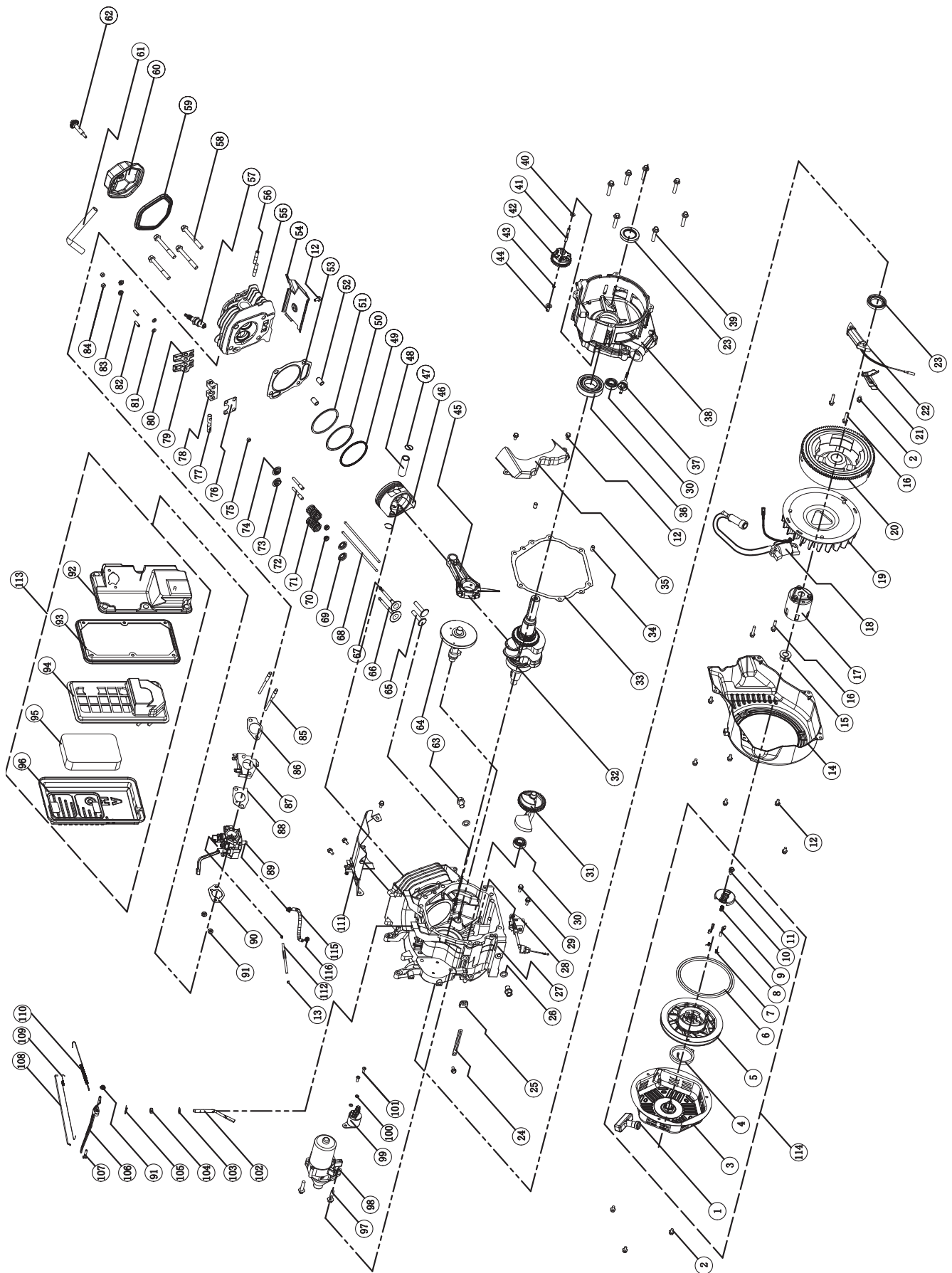

#	Part Number	Description	Qty
1	21.061300.00	Recoil Handle	1
2	1.5789.0608	Flange bolt M6x8	4
3	46.061100.00.2	Recoil Starter Cover	1
4	45.060005.00	Recoil Starter Spring	1
5	45.061102.00	Recoil Starter Reel	1
6	2.10.003	Rope (ø5x1550)	1
7	45.060003.00	Spring,Ratchet	2
8	45.060002.00	Starter Ratchet (Iron)	2
9	45.060009.00	Spring,Ratchet Guide	1
10	45.060007.00	Ratchet Guide	1
11	45.060008.00	Screw, Ratchet Guide	1
12	1.5789.0612	Flange bolt M6x12	12
13	2.06.006	Clip(ø7xø1)	2
14	46.080100.01.76	Fan Cover	1
15	2.02.007	Nut (M16x1.5)	1
16	1.5789.0629	Flange bolt 6x29	4
17	45.060001.00	Pulley, Starter	1
18	46.123000.03	Ignition Coil	1
19	45.080001.00	Cooling Fan	1
20	46.120100.02	Flywheel (Electric Start EPA)	1
21	45.030006.00	Plate, Coil	1
22	45.121000.00	Coil, Charging	1
23	2.11.007	Oil Seal (ø35xø52x8)	2
24	2.05.050	Wire clip	1
25	45.030032.00	Sheath, Wire	1
26	2.03.023	Washer (ø12.5xø20x2)	2
27	46.030100.01	Crankcase	1
28	45.127000.01	Oil Level Sensor	1
29	1.5789.0615	Flange bolt 6x15	2
30	1.276.6202	Bearing 6202	2
31	45.050006.00	Weight Balancer	1
32	45.050100.14	Crankshaft	1
33	46.030008.00	Gasket, Crankcase Cover	1
34	2.04.001	Dowel Pin (ø9x14)	2
35	46.080600.00	Air Guide, Right Side	1
36	1.276.6207	Bearing 6207	1
37	46.031000.01	Oil Dipstick Assembly	1
38	45.030007.00	Cover, Crankcase	1
39	1.5789.0840.0.8	Flange bolt 8x40	7
40	2.03.021.1	Washer (ø6.4xø13x1)	1
41	45.110013.00	Shaft,Governor Gear	1
42	45.110100.00	Gear, Governor	1
43	21.110011.00	Clip, Governor Gear	1
44	45.110012.00	Bushing, Governor Gear	1
45	45.050200.00	Connecting Rod	1
46	46.050005.00	Piston	1
47	2.09.004	Circlip(ø21xø1)	2
48	45.050003.00	Wrist Pin	1
49	45.050303.00	Ring, Oil	1
50	46.050302.00	Ring, Second Piston	1
51	46.050301.00	Ring,First Piston	1
52	2.04.004	Dowel Pin(ø12x20)	2
53	46.030009.01	Gasket, Cylinder Head (no asbestos)	1
54	46.080400.00	Air Guide, Lower	1
55	46.010100.00	Cylinder Head	1
56	2.01.005	Stud.Bolt (M8x49)	2
57	2.15.008	Spark Plug (F7RTC)	1
58	2.08.014	Flange bolt 10x80	4
59	46.020002.00	Gasket, Cylinder Head Cover	1

#	Part Number	Description	Qty
60	46.021000.00	Cylinder Head Cover (CPE)	1
61	45.020001.02	Breather Tube	1
62	45.020100.00	Bolt, Cylinder Head Cover	1
63	2.08.039	Bolt, Drain (M12x1.5x15)	2
64	46.041000.00	Camshaft (EPA)	1
65	45.040013.00	Lifter, Valve	2
66	45.040002.00	Valve, Intake	1
67	45.040006.00	Valve, Exhaust	1
68	46.040005.00	Push Rod	2
69	45.040015.00	Retainer, Valve Spring (Down)	2
70	45.040017.00	Oil Seal, Valve	2
71	45.040003.00	Spring, Valve	2
72	23.040010.00	Bolt, Rocker Arm	2
73	45.040001.00	Retainer, Intake Valve Spring (Up)	1
74	45.040007.00	Retainer, Exhaust Valve Spring (Up)	1
75	45.040008.00	Rotator, Exhaust Valve	1
76	46.040004.00	Guide Plate Push Rod	1
77	46.040016.00	Shaft, Rocker Arm	1
78	46.040201.00	Retainer, Rocker Arm	1
79	46.040009.00	Rocker Arm, Intake Valve	1
80	46.040018.00	Rocker Arm, Exhaust Valve	1
81	1.97.1.06	Washer 6	2
82	22.040012.00	Screw, Valve Adjustment	2
83	1.6177.1.06	Flange Nut M6	2
84	21.040021.00	Nut, Lock	2
85	2.01.008	Stud.Bolt (M6xM8x105)	2
86	46.130002.20	Gasket, Insulator (No Asbestos)	1
87	45.130001.00	Insulator, Carburetor	1
88	46.130003.20	Gasket, Carburetor (No Asbestos)	1
89	46.133000.03	Mixer	1
90	46.130004.20	Gasket, Air Cleaner (No Asbestos)	1
91	1.6177.06	Flange Nut M6	3
92	46.091100.04	Base, Air Cleaner	1
93	45.091002.20	Seal, Air Cleaner	1
94	45.091001.20	Separator, Air Cleaner	1
95	45.091003.20	Element, Air Cleaner	1
96	46.091200.04	Cover, Air Cleaner	1
97	1.5789.0835	Flange bolt M8x35	2
98	45.125100.00	Starter Motor Assembly	1
99	45.125200.03	Relay, Starter (three gear)	1
100	1.93.05	Spring Washer 5	2
101	1.16674.0516	Flange bolt M5x16	2
102	45.110001.00	Shaft, Governor Arm	1
103	2.03.019	Washer (ø8.2xø17x0.8)	1
104	2.11.006	Oil Seal (ø7xø14x5)	1
105	45.110008.00	Pin, Shaft	1
106	45.110003.00	Arm, Governor	1
107	2.08.040	Bolt, Governor Arm (M6x21)	1
108	45.110006.00	Rod Governor	1
109	45.110005.00	Spring, Throttle Return	1
110	45.110007.00	Spring, Governor	1
111	46.080300.20	Air Guide, Upper	1
112	46.133025.00	Negative Pressure Rubber Hose	1
113	46.091000.04	Air Cleaner Assembly	1
114	46.061000.00	Recoil Assembly	1
115	46.130021.02	Gas Tube (Mixer to switch)	1
116	2.06.023	Hose Clamp	2

TROUBLESHOOTING

Problem	Cause	Solution
Generator will not start	No fuel	Add fuel
	Faulty spark plug	Replace spark plug
	Unit loaded during start up	Remove load from unit
	Low oil level	Fill crankcase to the proper level
		Place generator on a flat, level surface
Generator starts but runs roughly	Choke in the wrong position	Adjust choke
	Spark plug wire loose	Attach wire to spark plug
Generator shuts down during operation	Out of fuel	Fill LPG cylinder
	Low oil level	Fill crankcase to the proper level. Place generator on a flat, level surface
Generator cannot supply enough power or overheating	Generator is overloaded	Review load and adjust. See "Power Management"
	Insufficient ventilation	Check for air restriction. Move to a well ventilated area
No AC output	Cable not properly connected	Check all connections
	Connected device is defective	Replace defective device
	Circuit breaker is open	Reset circuit breaker
	Faulty brush assembly	Replace brush assembly (Service Center)
	Faulty AVR (auto voltage regulator)	Replace AVR (Service Center)
	Loose wiring	Inspect and tighten wiring connections
	Other	Contact the help line
Generator gallops	Engine governor defective	Contact the help line
Repeated circuit breaker tripping	Overload	Review load and adjust. See "Power Management"
	Faulty cords or device	Check for damaged, bare or frayed wires. Replace defective device

For further technical support:

Technical Service

Mon – Fri 8:30 AM – 5:00 PM (PST/PDT)

Toll Free: 1-877-338-0999

tech@championpowerequipment.com

WARRANTY

CHAMPION POWER EQUIPMENT
2 YEAR LIMITED WARRANTY

Warranty Qualifications

Champion Power Equipment (CPE) will register this warranty upon receipt of your Warranty Registration Card and a copy of your sales receipt from one of CPE's retail locations as proof of purchase.

Please submit your warranty registration and your proof of purchase within ten (10) days of the date of purchase.

Repair/Replacement Warranty

CPE warrants to the original purchaser that the mechanical and electrical components will be free of defects in material and workmanship for a period of one year (parts and labor) and two years (parts) from the original date of purchase (90 days (parts and labor) and 180 days (parts) for commercial & industrial use). Transportation charges on product submitted for repair or replacement under this warranty are the sole responsibility of the purchaser. This warranty only applies to the original purchaser and is not transferable.

Do Not Return The Unit To The Place Of Purchase

Contact CPE's Technical Service and CPE will troubleshoot any issue via phone or e-mail. If the problem is not corrected by this method, CPE will, at its option, authorize evaluation, repair or replacement of the defective part or component at a CPE Service Center. CPE will provide you with a case number for warranty service. Please keep it for future reference. Repairs or replacements without prior authorization, or at an unauthorized repair facility, will not be covered by this warranty.

Warranty Exclusions

This warranty does not cover the following repairs and equipment:

Normal Wear

Generators need periodic parts and service to perform well. This warranty does not cover repair when normal use has exhausted the life of a part or the equipment as a whole.

Installation, Use and Maintenance

This warranty will not apply to parts and/or labor if this generator is deemed to have been misused, neglected, involved in an accident, abused, loaded beyond the generator's limits, modified, installed improperly or connected incorrectly to any electrical component.

Installation, Use and Maintenance Cont'd.

Normal maintenance such as spark plugs, air filters, adjustments, fuel system cleaning and obstruction due to buildup is not covered by this warranty.

Other Exclusions

This warranty excludes:

- Cosmetic defects such as paint, decals, etc.
- Wear items such as filter elements, o-rings, etc.
- Accessory parts such as starting batteries, and storage covers.
- Failures due to acts of God and other force majeure events beyond the manufacturer's control.
- Problems caused by parts that are not original Champion Power Equipment parts.

This warranty does not apply to generators used for prime power in place of a utility.

Limits of Implied Warranty and Consequential Damage

Champion Power Equipment disclaims any obligation to cover any loss of time, use of this product, freight, or any incidental or consequential claim by anyone from using this generator. THIS WARRANTY IS IN LIEU OF ALL OTHER WARRANTIES, EXPRESS OR IMPLIED, INCLUDING WARRANTIES OF MERCHANTABILITY OR FITNESS FOR A PARTICULAR PURPOSE.

A unit provided as an exchange will be subject to the warranty of the original unit. The length of the warranty governing the exchanged unit will remain calculated by reference to the purchase date of the original unit.

This warranty gives you certain legal rights which may change from state to state. Your state may also have other rights you may be entitled to that are not listed within this warranty.

Contact Information

Address

Champion Power Equipment, Inc.
Customer Service
10006 Santa Fe Springs Rd.
Santa Fe Springs, CA 90670
www.championpowerequipment.com

Customer Service

Mon – Fri 8:30 AM – 5:00 PM (PST/PDT)
Toll Free: 1-877-338-0999
info@championpowerequipment.com
Fax no.: 1-562-236-9429

Technical Service

Mon – Fri 8:30 AM – 5:00 PM (PST/PDT)
Toll Free: 1-877-338-0999
tech@championpowerequipment.com
24/7 Tech Support: 1-562-204-1188

**Champion Power Equipment, Inc. (CPE),
The United States Environment Protection Agency (U.S. EPA.) and the California Air Resources Board (CARB)
Emission Control System Warranty**

Your Champion Power Equipment (CPE) engine complies with both the U.S. EPA and state of California Air Resources Board (CARB) emission regulations.

YOUR WARRANTY RIGHTS AND OBLIGATIONS:

The US EPA, California Air Resources Board, and CPE are pleased to explain the Federal and California Emission Control Systems Warranty on your 2013 small off-road engine and engine powered equipment. In California, new, small off-road engines and new equipment that use small off-engines must be designed, built and equipped to meet the State's stringent anti smog standards. In the other states, new engines and equipment must be designed, built and equipped, at the time of sale, to meet U.S. EPA regulations for small non-road engines. CPE warrants the emission control system on your small off-road engine and equipment for the period of time listed below, provided there has been no abuse, neglect, unapproved modification, or improper maintenance of your equipment.

Your emission control system may include parts such as the carburetor, fuel-injection system, the ignition system, catalytic converter and fuel lines. Also included may be hoses, belts, connectors and other emission related assemblies. Where a warrantable condition exists, CPE will repair your small off-road engine at no cost to you including diagnosis, parts and labor. For engines less than or equal to 80cc, only the fuel tank and fuel line is subject to the evaporative emission control warranty requirements of this section.

MANUFACTURER'S EMISSION CONTROL SYSTEM WARRANTY COVERAGE:

This emission control system is warranted for two years, subject to provisions set forth below. If, during the warranty period, emission related part on your engine is defective in materials or workmanship, the part will be repaired or replaced by CPE.

OWNER WARRANTY RESPONSIBILITIES:

As the small off-road engine owner, you are responsible for the performance of the required maintenance listed in your Owner's Manual. CPE recommends that you retain all your receipts covering maintenance on your small off-road engine, but CPE cannot deny warranty solely for the lack of receipts or for your failure to ensure the performance of all scheduled maintenance.

As the small off-road engine owner, you should however be aware that CPE may deny you warranty coverage if your small, off-road engine or a part has failed due to abuse, neglect, improper maintenance or unapproved modifications.

You are responsible for presenting your small off-road engine to an Authorized CPE service outlet or alternate service outlet as described in (3)(f.) below, CPE dealer or CPE, Santa Fe Springs, Ca. as soon as a problem exists. The warranty repairs should be completed in a reasonable amount of time, not to exceed 30 days.

If you have any questions regarding your warranty rights and responsibilities, you should contact:

Champion Power Equipment, Inc.
Customer Service
10006 Santa Fe Springs Road
Santa Fe Springs, CA 90670
1-877-338-0999
tech@championpowerequipment.com

EMISSION CONTROL SYSTEM WARRANTY

The following are specific provisions relative to your Emission Control System (ECS) Warranty Coverage.

1. APPLICABILITY: This warranty shall apply to 1995 and later model year California small off-road engines (for other states, 1997 and later model year engines). The ECS Warranty Period shall begin on the date the new engine or equipment is delivered to its original, end-use purchaser, and shall continue for 24 consecutive months thereafter.

2. GENERAL EMISSIONS WARRANTY COVERAGE

CPE warrants to the original, end-use purchaser of the new engine or equipment and to each subsequent purchaser that each of its small off-road engines is:

a. Designed, built and equipped so as to conform to U.S. EPA emissions standards for spark-ignited engines at or below 19 kilowatts and all applicable regulations adopted by the California Air Resources Board and

b. Free from defects in materials and workmanship that cause the failure of a warranted part to be identical in all material respects to the part as described in the engine manufacturer's application for certification for a period of two years.

3. THE WARRANTY ON EMISSION-RELATED PARTS WILL BE INTERPRETED AS FOLLOWS:

a. Any warranted part that is not scheduled for replacement as required maintenance in the Owners Manual shall be warranted for the ECS Warranty Period. If any such part fails during the ECS Warranty Period, it shall be repaired or replaced by CPE according to Subsection "d" below. Any such part repaired or replaced under the ECS Warranty shall be warranted for any remainder of the ECS Warranty Period.

b. Any warranted, emissions-related part which is scheduled only for regular inspection as specified in the Owners Manual shall be warranted for the ECS Warranty Period. A statement in such written instructions to the effect of "repair or replace as necessary", shall not reduce the ECS Warranty Period. Any such part repaired or replaced under the ECS Warranty shall be warranted for the remainder of the ECS Warranty Period.

c. Any warranted, emissions-related part which is scheduled for replacement as required maintenance in the Owner's Manual shall be warranted for the period of time prior to the first scheduled replacement point for that part. If the part fails prior to the first scheduled replacement, the part shall be repaired or replaced by CPE according to Subsection "d" below. Any such emissions-related part repaired or replaced under the ECS Warranty, shall be warranted for the remainder of the ECS Warranty Period prior to the first scheduled replacement point for such emissions-related part.

d. Repair or replacement of any warranted, emissions-related part under this ECS Warranty shall be performed at no charge to the owner at a CPE Authorized Service Outlet.

e. The owner shall not be charged for diagnostic labor which leads to the determination that a part covered by the ECS Warranty is in fact defective, provided that such diagnostic work is performed at a CPE Authorized Service Outlet.

f. CPE shall pay for covered emissions warranty repairs at non-authorized service outlets under the following circumstances:

i. The service is required in a population center with a population over 100,000 according to U.S. Census 2000 without a CPE Authorized Service Outlet AND

ii. The service is required more than 100 miles from a CPE Authorized Service Outlet. The 100 mile limitation does not apply in the following states: Alaska, Arizona, Colorado, Hawaii, Idaho, Montana, Nebraska, Nevada, New Mexico, Oregon, Texas, Utah and Wyoming.

g. CPE shall be liable for damages to other original engine components or approved modifications proximately caused by a failure under warranty of an emission-related part covered by the ECS Warranty.

h. Throughout the ECS Warranty Period, CPE shall maintain a supply of warranted emission-related parts sufficient to meet the expected demand for such emission-related parts.

i. Any CPE Authorized and approved emission-related replacement part may be used in the performance of any ECS Warranty maintenance or repair and will be provided without charge to the owner. Such use shall not reduce CPE's warranty obligation.

j. Unapproved add-on or modified parts may not be used to modify or repair a CPE engine. Such use voids this ECS Warranty and shall be sufficient grounds for disallowing an ECS Warranty claim. CPE shall not be liable hereunder for failures of any warranted parts of a CPE engine caused by the use of such an unapproved add-on or modified part.

EMISSION-RELATED PARTS INCLUDE THE FOLLOWING: (using those portions of the list applicable to the engine)

Systems covered by this warranty	Parts Description
Fuel Metering System	Fuel regulator, Carburetor and internal parts
Air Induction System	Air cleaner, Intake manifold
Ignition System	Spark plug and parts, Magneto ignition system
Exhaust System	Exhaust manifold, catalytic converter
Miscellaneous Parts	Tubing, Fittings, Seals, Gaskets, and Clamps associated with these listed systems.
Evaporative Emissions	Fuel Tank, Fuel Cap, Fuel Line, Fuel Line Fittings, Clamps, Pressure Relief Valves, Control Valves, Control Solenoids, Electronic Controls, Vacuum Control Diaphragms, Control Cables, Control Linkages, Purge Valves, Vapor Hoses, Liquid/Vapor Separator, Carbon Canister, Canister Mounting Brackets, Carburetor Purge Port Connector

TO OBTAIN WARRANTY SERVICE:

You must take your CPE engine or the product on which it is installed, along with your warranty registration card or other proof of original purchase date, at your expense, to any Champion Power Equipment dealer who is authorized by Champion Power Equipment, Inc. to sell and service that CPE product during his normal business hours. Alternate service locations defined in Section (3)(f.) above must be approved by CPE prior to service. Claims for repair or adjustment found to be caused solely by defects in material or workmanship will not be denied because the engine was not properly maintained and used.

If you have any questions regarding your warranty rights and responsibilities, or to obtain warranty service, please write or call Customer Service at Champion Power Equipment, Inc.

**Champion Power Equipment, Inc.
10006 Santa Fe Springs Road
Santa Fe Springs, CA 90670
1-877-338-0999
Attn.: Customer Service
tech@championpowerequipment.com**