

CHAMPION

POWER EQUIPMENT™

10006 Santa Fe Springs Road
Santa Fe Springs, CA 90670 USA
Made in China

66501
Rev 66501-20090413



Owner's Manual and Operating Instructions

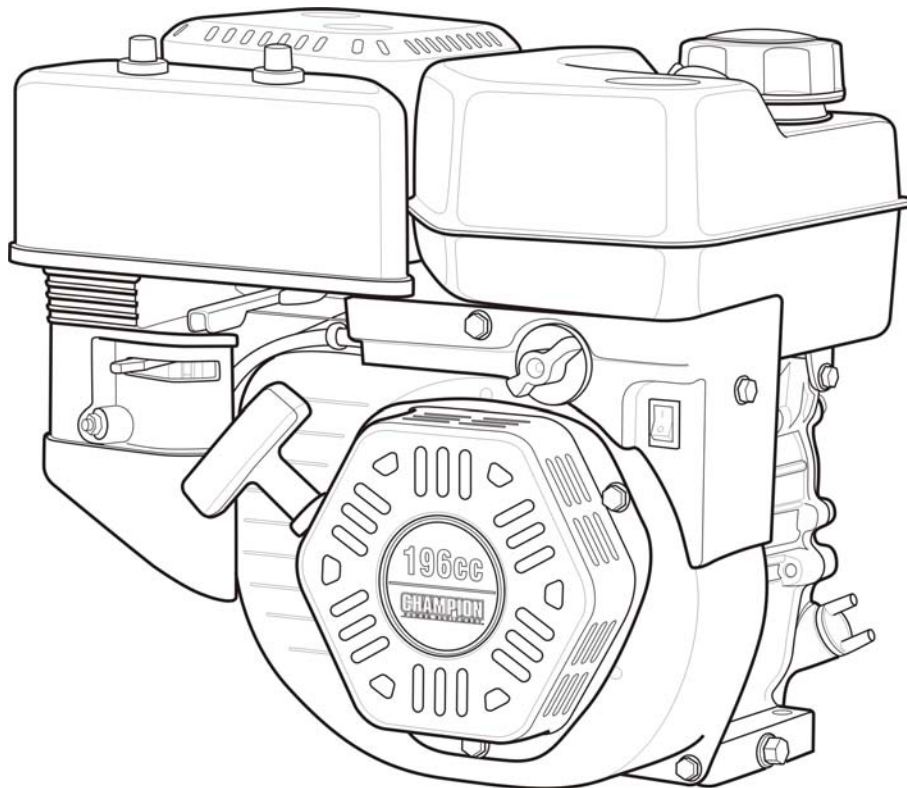

SAVE THESE INSTRUCTIONS

**Important Safety
Instructions are included in
this manual**

196cc

REPLACEMENT ENGINE

Table of Contents

Introduction	1	Specifications	12
Replacement Engine.....	1	Engine Specifications.....	12
Accessories.....	1	Fuel.....	12
This Booklet.....	1	Oil.....	12
Manual Conventions	2	Spark Plugs	12
Safety Rules	3	Valve Clearance.....	12
Controls and Features.....	5	Keyway Shaft.....	12
Replacement Engine.....	5	Dimensions	13
Assembly	7	Parts Diagram	14
Add Engine Oil	7	Parts List	15
Add Fuel.....	7	Troubleshooting	18
Operation	8	Warranty	18
Engine Location.....	8	Warranty Qualifications	18
Starting the Engine.....	8	Repair/Replacement Warranty.....	18
Stopping the Engine	8	Do not return the unit to the place of	
Maintenance	9	purchase	18
Engine Maintenance.....	9	Warranty Exclusions.....	18
Oil.....	9	Normal Wear	18
Spark Plugs	9	Installation, Use and Maintenance.....	19
Air Filter.....	9	Other Exclusions	19
Cleaning	10	Limits of Implied Warranty and	
Adjustments.....	10	Consequential Damage	19
Maintenance Schedule.....	10	Contact Information	19
Storage	11	Address.....	19
Engine Storage.....	11	Customer Service	19
		Technical Service.....	19
		Notes	23

Introduction

Congratulations on your purchase of a Champion Power Equipment engine. CPE designs and builds engines to strict specifications. With proper use and maintenance, this engine will bring years of satisfying service.

This Owner's Manual contains important safety instructions and information. **SAVE THESE INSTRUCTIONS FOR FUTURE REFERENCE.**

Replacement Engine

This unit is a gasoline driven, key-way shaft replacement engine. It is designed to supply power for air compressors, pumps, pressure washers, reel-type lawn mowers, go-carts, agricultural and construction equipment and other pulley-style applications.

Record the model and serial numbers as well as date and place of purchase for future reference. Have this information available when ordering parts and when making technical or warranty inquiries.

Champion Power Equipment Support
1-877-338-0999
Model Number
66501
Serial Number
Date of Purchase
Purchase Location

Accessories

Champion Power Equipment manufactures and sells accessories designed to help you get the most from your purchase. To find out more, please visit our web site at

www.championpowerequipment.com

This Booklet

Every effort has been made to ensure the accuracy and completeness of the information in this manual. We reserve the right to change, alter and/or improve the product and this document at any time without prior notice.

Manual Conventions

Manual Conventions

This manual uses the following symbols to help differentiate between different kinds of information. The safety symbol is used with a key word to alert you to potential hazards in operating and owning power equipment.

Follow all safety messages to avoid or reduce the risk of serious injury or death.

DANGER

DANGER indicates an imminently hazardous situation which, if not avoided, *will* result in death or serious injury.

WARNING

WARNING indicates a potentially hazardous situation which, if not avoided, *could* result in death or serious injury.

CAUTION

CAUTION indicates a potentially hazardous situation which, if not avoided, *may* result in minor or moderate injury.

CAUTION

CAUTION used without the safety alert symbol indicates a potentially hazardous situation which, if not avoided, *may* result in property damage.

NOTE

If you have questions regarding your engine, we can help. Please call our help line at 1-877-338-0999.

Safety Rules

WARNING

Read this manual thoroughly before operating your engine. Failure to follow instructions could result in serious injury or death.

WARNING

The engine exhaust from this product contains chemicals known to the state of California to cause cancer, birth defects, or other reproductive harm.

DANGER

Engine exhaust contains carbon monoxide, a colorless, odorless, poison gas. Breathing carbon monoxide will cause nausea, dizziness, fainting or death. If you start to feel dizzy or weak, get to fresh air immediately.

Operate generator outdoors only in a well ventilated area
DO NOT operate the generator inside any building, including garages, basements, crawlspaces and sheds, enclosure or compartment, including the generator compartment of a recreational vehicle.
DO NOT allow exhaust fumes to enter a confined area through windows, doors, vents or other openings.

DANGER CARBON MONOXIDE, using a generator indoors **CAN KILL YOU IN MINUTES**.

DANGER

Rotating parts can entangle hands, feet, hair, clothing and/or accessories.

Traumatic amputation or severe laceration can result.

Keep hands and feet away from rotating parts.
Tie up long hair and remove jewelry.
Operate equipment with guards in place.
DO NOT wear loose-fitting clothing, dangling drawstrings or items that could become caught.

WARNING

Sparks can result in fire or electrical shock.

When servicing the engine:

Disconnect the spark plug wire and place it where it cannot contact the plug.
DO NOT check for spark with the plug removed.
Use only approved spark plug testers.

WARNING

Running engines produce heat.
Severe burns can occur on contact.
Combustible material can catch fire on contact.

DO NOT touch hot surfaces.
Avoid contact with hot exhaust gases.
Allow equipment to cool before touching.
Maintain at least three feet of clearance on all sides to ensure adequate cooling.
Maintain at least five feet of clearance from combustible materials.

Safety Rules

DANGER

Fuel and fuel vapors are highly flammable and extremely explosive.

Fire or explosion can cause severe burns or death.

Unintentional startup can result in entanglement, traumatic amputation or laceration.

When adding or removing fuel

Turn the engine off and let it cool for at least two minutes before removing the fuel cap. Loosen the cap slowly to relieve pressure in the tank. Only fill or drain fuel outdoors in a well-ventilated area.

DO NOT overfill the fuel tank.

Always keep fuel away from sparks, open flames, pilot lights, heat and other sources of ignition.

DO NOT light or smoke cigarettes.

When starting the engine

DO NOT attempt to start a damaged engine.

Make certain that the gas cap, air filter, spark plug, fuel lines and exhaust system are properly in place.

Allow spilled fuel to evaporate fully before attempting to start the engine.

Make certain that the engine is resting firmly on level ground.

When transporting or servicing the engine:

Make certain that the fuel shutoff valve is in the off position and the fuel tank is empty.

Disconnect the spark plug wire.

When storing the engine:

Store away from sparks, open flames, pilot lights, heat and other sources of ignition.

WARNING

Rapid retraction of the starter cord will pull hand and arm towards the engine faster than you can let go.

Unintentional startup can result in entanglement, traumatic amputation or laceration.

Broken bones, fractures, bruises or sprains could result.

When starting engine, pull the starter cord slowly until resistance is felt and then pull rapidly to avoid kickback.

DO NOT start or stop the engine with electrical devices plugged in.

CAUTION

Improper treatment or use of the engine can damage it, shorten its life and void your warranty.

Use the engine only for intended uses.

Operate only on level surfaces.

DO NOT expose engine to excessive moisture, dust, or dirt.

DO NOT allow any material to block the cooling slots.

DO NOT use the engine if:

Equipment sparks, smokes or emits flames

Equipment vibrates excessively

Controls and Features

Read this owner's manual before operating your engine. Familiarize yourself with the location and function of the controls and features. Save this manual for future reference.

Replacement Engine

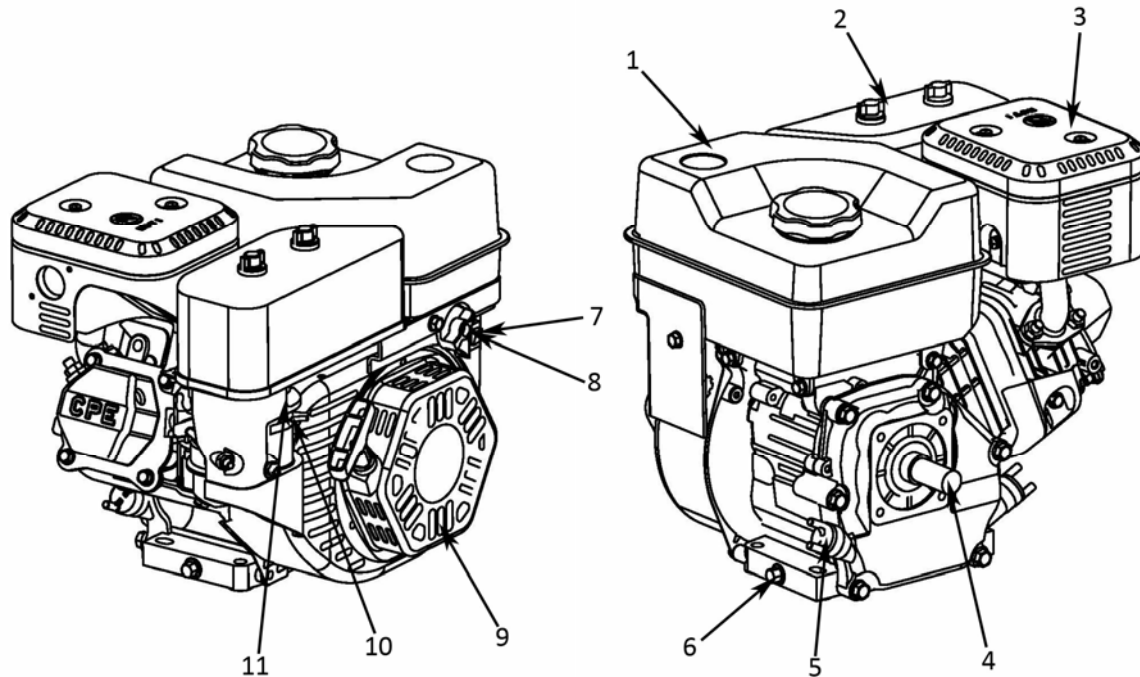

(1) Fuel Tank – 0.93 gallon capacity fuel tank.

(2) Air Cleaner – Protects the engine by filtering dust and debris from the intake air.

(3) Muffler

(4) Horizontal shaft

(5) Oil Filler Cap – Check and fill engine oil level.

(6) Oil Drain Plug – Used to drain the oil

(7) Engine Switch - Flip Switch to “On” position to start engine.

(8) Fuel Valve Knob – Turn this valve to the “On” position to supply fuel to the engine.

(9) Recoil Starter – Used to start the engine.

(10) Choke – Used to start the engine.

(11) Throttle – Controls the engine speed.

Controls and Features

Parts Included

Your 66501 Gasoline Powered Engine ships with the following parts:



Spark Plug Socket

1 piece

Assembly

This unit ships from our factory without oil. It must be properly serviced with fuel and oil before operation.

Add Engine Oil

CAUTION

DO NOT attempt to crank or start the engine before it has been properly filled with the recommended type and amount of oil. Damage to the generator as a result of failure to follow these instructions will void your warranty.

1. Place the engine on a flat, level surface.
2. Remove oil fill cap/dipstick to add oil.
3. Add 0.63 qt (0.6 L) of oil and replace oil fill cap/dipstick.
4. Check engine oil level daily and add as needed.

CAUTION

The engine is equipped with a low-oil-shutoff and will stop when the oil level in the crankcase falls below the threshold level.

NOTE

Check oil often during the break-in period. Refer to the Maintenance section for recommended service intervals.

Add Fuel

1. Use clean, fresh, regular unleaded fuel with a minimum octane rating of 85.
2. DO NOT mix oil with fuel.
3. Clean the area around the fuel cap.
4. Remove the fuel cap
5. Slowly add fuel to the tank. DO NOT overfill. Allow approximately ¼ inch of space for fuel expansion.
6. Screw on the fuel cap and wipe away any spilled fuel.

CAUTION

Use regular unleaded gasoline with a minimum octane rating of 85.

DO NOT mix oil and gasoline.
Fill tank to approximately ¼" below the top of the tank to allow for fuel expansion.
DO NOT fill fuel tank indoors.
DO NOT fill fuel tank when the engine is running or hot.
DO NOT overfill the fuel tank.
DO NOT light cigarettes or smoke when filling the fuel tank.

Operation

Operation

Engine Location

Place the engine in a well-ventilated area. DO NOT place the engine near vents or intakes where exhaust fumes could be drawn into occupied or confined spaces. Carefully consider wind and air currents when positioning engine.

Starting the Engine

1. Make certain the engine is on a flat, level surface.
2. Flip engine switch to "ON" position (Item A)
3. Rotate the fuel valve to the "ON" position (to the left) (Item B). See image below



4. Move the choke lever (Item A) to the "Choke" position (to the left).

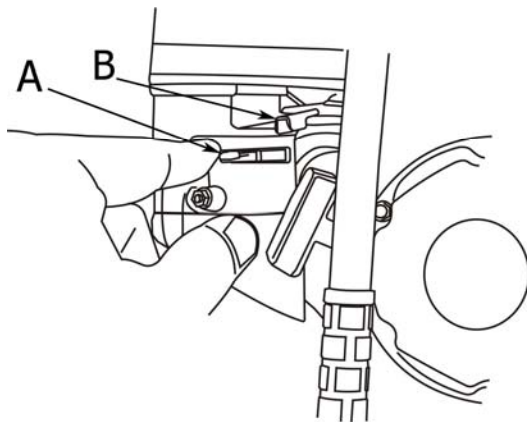

5. Pull the starter cord slowly until resistance is felt and then pull rapidly.
6. As engine warms up, move the choke lever to "Run" (to the right).

7. Move the throttle lever (Item B) to the "Fast" position.

NOTE

If the engine starts but does not run, make certain that it is on a flat, level surface. The engine is equipped with a low oil sensor that will prevent the engine from running when the oil level falls below a critical threshold.

Stopping the Engine

1. Let the engine run at no-load for several minutes to stabilize internal temperatures.
2. Turn the ignition switch to the "Off" position.
3. Turn the fuel valve to the "Off" position.

Maintenance

The owner/operator is responsible for all periodic maintenance.

WARNING

Never operate a damaged or defective engine.

WARNING

Improper maintenance will void your warranty.

Complete all scheduled maintenance in a timely manner. Correct any issue before operating the engine.

NOTE

For service or parts assistance, contact our help line at 1-877-338-0999.

Engine Maintenance

To prevent accidental starting, remove and ground spark plug wire before performing any service.

Oil

Change oil when the engine is warm. Refer to the oil specification to select the proper grade of oil for your operating environment.

CAUTION

The engine ships from the factory without oil. Before pulling the recoil start or starting the engine, fill with oil. Do not overfill.

1. Remove the oil drain plug with a 12 mm socket and extension.
2. Allow the oil to drain completely.
3. Replace the drain plug.
4. Remove oil fill cap/dipstick to add oil.
5. Add 0.63 qt (0.6 L) of oil and replace oil fill cap/dipstick.

6. Dispose of used oil at an approved waste management facility.

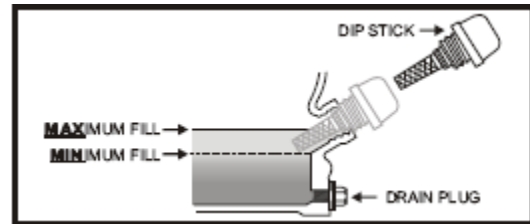

Spark Plugs

1. Remove the spark plug cable from the spark plug.
2. Use the spark plug tool that shipped with your engine to remove the plug.
3. Inspect the electrode on the plug. It must be clean and not worn to produce the spark required for ignition.
4. Make certain the spark plug gap is 0.7 - 0.8mm (0.028 - 0.031 in.).
5. Refer to the spark plug recommendation chart when replacing the plug.
6. Carefully thread the plug into the engine.
7. Use the spark plug tool to firmly install the plug.
8. Attach the spark plug wire to the plug.

Air Filter

1. Unscrew wing nut to remove the air filter cover.
2. Unscrew wing nut to remove the air filter.
3. Separate the foam element and the paper element.
4. Tap the paper filter element to remove dirt and debris. Use compressed air (25 PSI) to clear debris.
5. For the foam element: Wash in liquid detergent and water. Squeeze thoroughly dry in a clean cloth.
6. Saturate in clean engine oil.
7. Squeeze in a clean, absorbent cloth to remove all excess oil.
8. Reassemble the two elements and reattach. Tighten wing nut
9. Reattach the air filter cover and snap in place.

Maintenance

Cleaning



CAUTION

DO NOT spray engine with water.

Water can contaminate the fuel system.

Use a damp cloth to clean exterior surfaces of the engine.

Use a soft bristle brush to remove dirt and oil.

Use an air compressor (25 PSI) to clear dirt and debris from the engine.

Adjustments

The air-fuel mixture is not adjustable. CPE recommends that you contact our service line at 1-877-338-0999 for all other service and/or adjustment needs.

Maintenance Schedule

Follow the service intervals indicated in the schedule below.

Service your engine more frequently when operating in adverse conditions.

Contact our help line at 1-877-338-0999 to locate the nearest Champion Power Equipment certified service dealer for your engine maintenance needs.

Every 8 hours or daily
Check oil level
Clean around air intake and muffler
First 5 Hours
Change oil
First 10 hours
Check/Adjust Valve Clearance *
Every 50 hours or every season
Clean air filter
Change oil if operating under heavy load or in hot environments
Every 100 hours or every season
Change oil
Clean/Adjust spark plug
Check/Adjust valve clearance *
Clean spark arrester
Clean fuel tank and filter *
Every 3 years
Replace fuel line

* To be performed by knowledgeable, experienced owners or Champion Power Equipment certified service dealers

Storage

Engines stored for over 30 days need to be drained of fuel to prevent gum from forming in the fuel system, carburetor components and hoses. For long term storage, please follow these guidelines.

Engine Storage

1. Allow the engine to cool completely before storage.
2. Clean the engine according to the instructions in the Maintenance section.
3. Drain all fuel completely from the fuel line and carburetor to prevent gum from forming.
4. Add a fuel stabilizer into the fuel tank.
5. Change the oil.
6. Remove the spark plug and pour about $\frac{1}{2}$ ounce of oil into the cylinder. Crank the engine slowly to distribute the oil and lubricate the cylinder.
7. Reattach the spark plug.

Specifications

Specifications

Engine Specifications

Engine	196 cc OHV CPE
PTO Rotation	Counterclockwise
Ignition Mode	TCI (transistorized)
Displacement	196 cc
Torque (max)	8.7 ft. lbs. at 2800 RPM
Compression	8.5:1
Horizontal Shaft	$\frac{3}{4}$ " x 2 $\frac{7}{16}$ " 1.91 cm x 6.17 cm
End Hole	Tapped 5/16" 24 UNF
Fuel Capacity	0.93 gallons (3.5 L)
Weight	37.5 lbs. (17 kg)
Height	13.35 inches (33.9 cm)
Width	12.14 inches (30.8 cm)
Length	14.25 inches (36.2 cm)

Fuel

Fuel capacity is 0.93 US gallons (3.5L). Use regular unleaded gasoline with a minimum octane rating of 85.

Oil

Oil capacity is 0.63 qt (0.6 L).

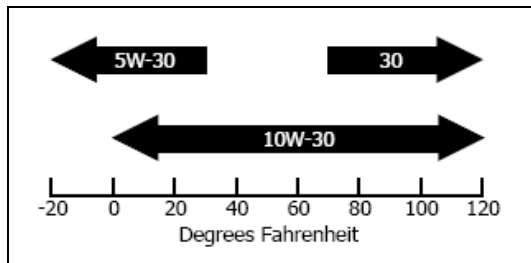

Spark Plugs

Your engine comes equipped with a $\frac{3}{4}$ " long reach plug (19mm).

Intermittent use (less than 1 hour/month) or colder temperatures (below 60°F):
NGK B6ES or equivalent

Moderate use (less than 3 hours/month) or seasonal temperatures (50-80°F):
NGK B7ES or equivalent

Extreme use (continuous) or hot climates (80-100°F):
NGK B8ES or equivalent

Make certain the spark plug gap is 0.7 - 0.8mm (0.028 - 0.031 in.).

Valve Clearance

Intake 0.10-0.12mm (0.004 - 0.005 in.)
Exhaust 0.10-0.12mm (0.004 - 0.005 in.)

Keyway Shaft

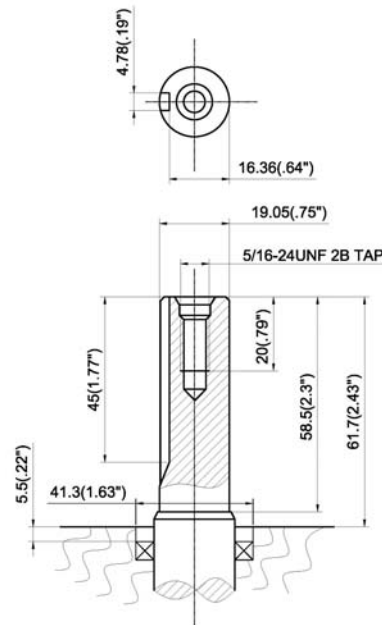

Dimensions

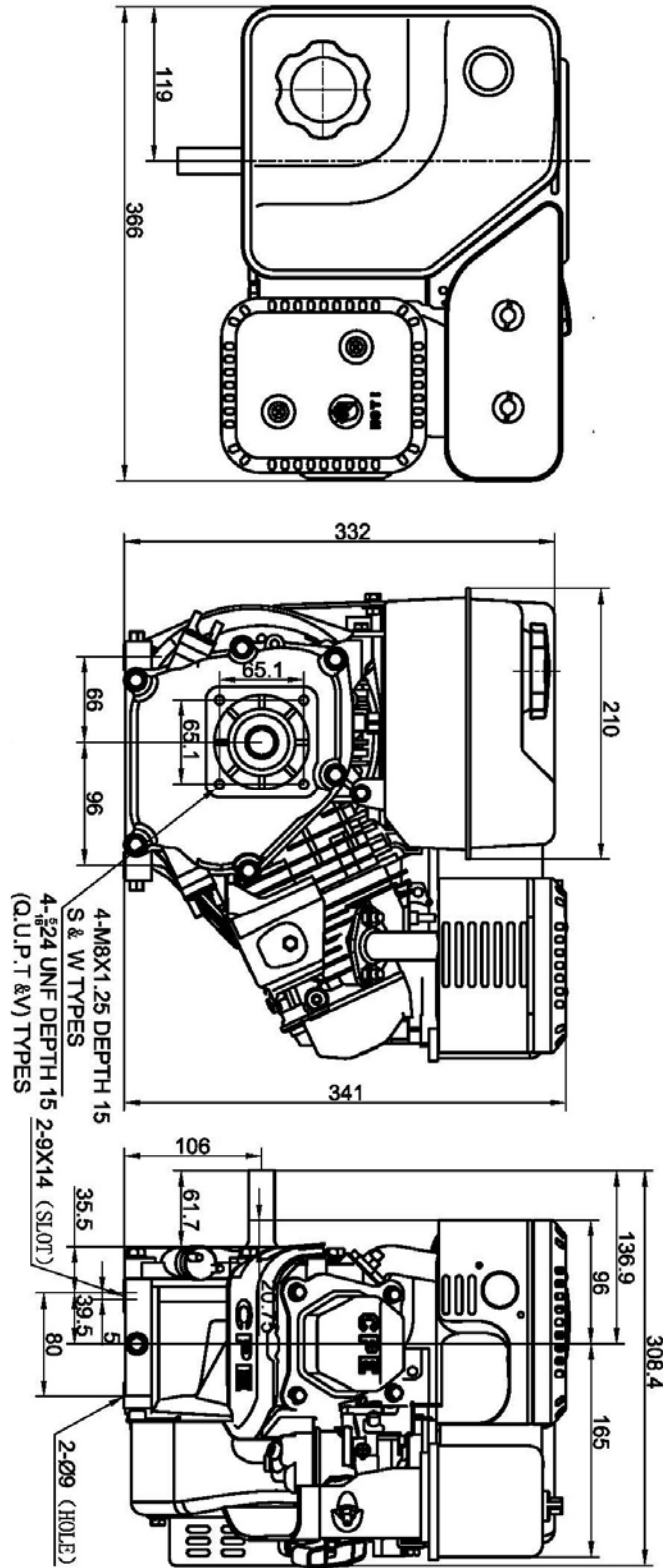

Specifications

Parts Diagram

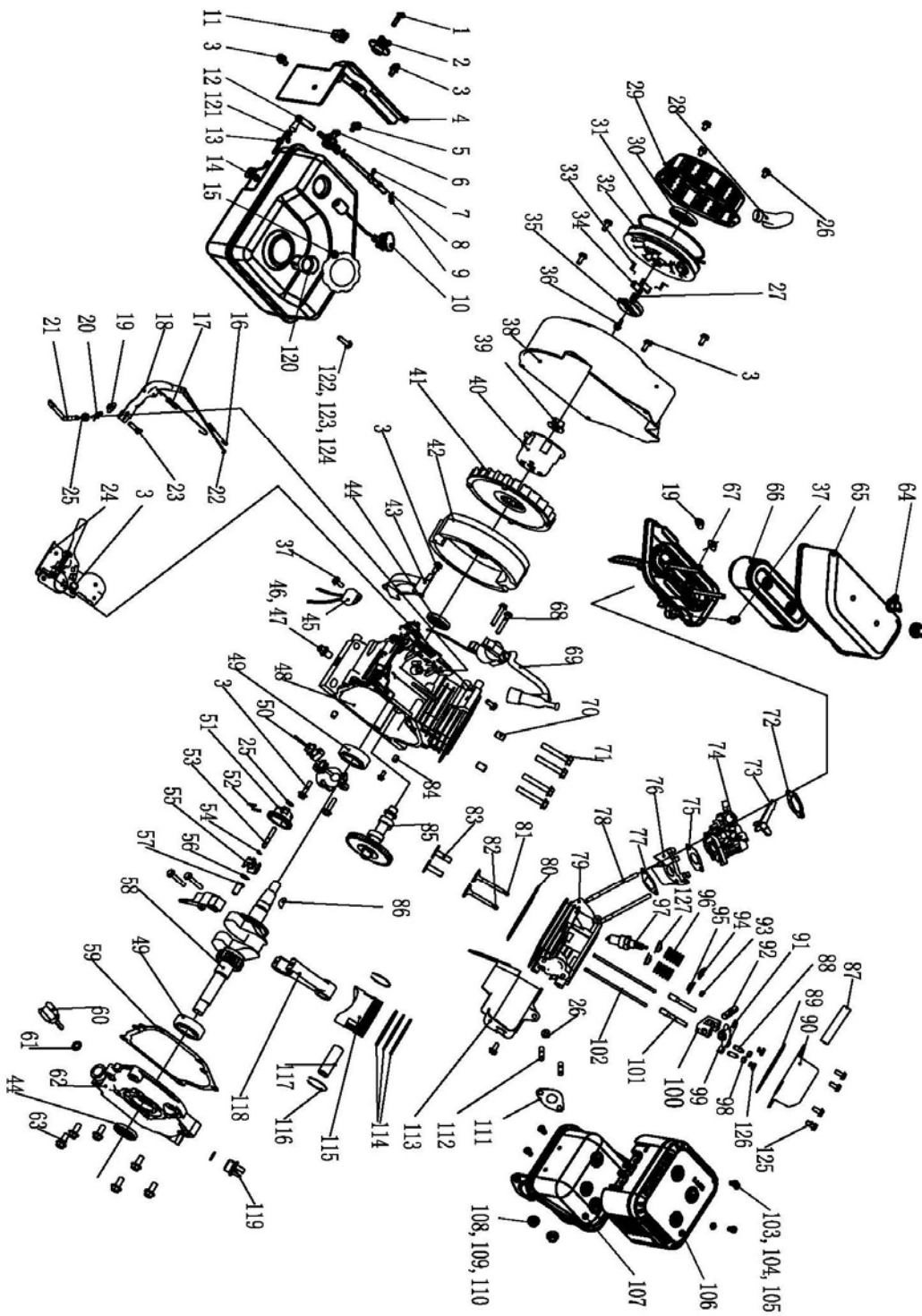

Parts List

Item	Part Number	Description	Qty
1	GB5781-B4-12	Bolt M4×12	1
2	ST168F-1070003-G	Fuel Valve Knob	1
3	GB5789-FB6-12	Flange Bolt M6×12	11
4	ST168F-1070002-G	Fuel Tank Shroud	1
5	GB5789-FB5-12	Flange Bolt M5×12	1
6	ST168F-1070200-G	Fuel Valve	1
7	ST168F-1070008-G	Tube Clip	1
8	ST168F-1070004-G	Tube, I	1
9	ST188FD-1070006A	Clip	3
10	ST168F-1071000-CARB	Fuel Meter Assembly	1
11	ST168F-1121100-C	Switch	1
12	ST168F-1070005-G	Tube, II	1
13	ST152FD-1070200	Fuel Filter	1
14	ST168F-1070100-G	Fuel Tank	1
15	ST160F-1070100H	Fuel Tank Cap	1
16	ST168F-1110005	Throttle Return Spring	1
17	ST168F-1110007	Governor Spring	1
18	ST160F-1110003	Governor Arm	1
19	GB41-N-6	Nut M6	3
20	ST160F-1110008	Lock Pin	1
21	ST160F-1110001	Governor Arm Shaft	1
22	ST168F-1110006	Governor Rod	1
23	ST160F-1110004	Governor Arm Bolt	1
24	ST168F-1111000	Control Assembly	1
25	ST160F-1110108	Governor Washer	2
26	GB5789-FB6-8	Flange Bolt M6×8	5
27	ST188F-1060004	Ratchet Guide Spring	1
28	ST160F-1061200	Recoil Starter Knob	1
29	ST160F-1061100-Q	Recoil Starter Cover	1
30	ST160F-1061005	Recoil Starter Spring	1
31	ST160F-1061009	Recoil Starter Rope	1
32	ST160F-1061001-A	Recoil Starter Reel	1
33	ST188F-1060006	Return Spring	2
34	ST188F-1060005	Starter Ratchet	2
35	ST188F-1060003	Ratchet Guide	1
36	ST188F-1060002	Setting Screw	1
37	GB5789-FB6-20	Flange Bolt M6×20	4
38	ST168F-1080100-G	Fan Cover	1
39	ST160F-1050010	Nut M14	1
40	ST160F-1060001	Start Hub	1
41	ST168F-1080001	Cooling Fan	1
42	ST168F-1120100	Flywheel	1
43	ST168F-1080200	Side Place	1
44	ST168F-1030100	Oil Seal	2
45	ST160F-1129000-G	Diode Comp	1
46	ST160F-1030003	Drain Plug Bolt	2
47	ST160F-1030004	Drain Bolt Washer	2
48	ST168F-2-1030012-G	Crankcase	1
49	GB276-BB-6205-UU	Radial Ball Bearing 6205 Unsealed	2
50	ST160F-1127000-A	Oil Level Switch	1
51	ST160F-1110101	Governor Weight Holder	1
52	ST160F-1110102	Governor Weight Pin	2
53	ST160F-1110104	Governor Shaft	1
54	ST160F-1110103	Governor Holder Clip	1
55	ST160F-1110107	Governor Weight	2
56	ST160F-1110106	Governor Shaft Washer	1
57	ST160F-1110105	Governor Cover	1
58	ST168F-1050001-Q	Threaded Crankshaft	1

Specifications

Item	Part Number	Description	Qty
59	ST168F-1030008-G	Case Cover Packing	1
60	ST160F-1030001-B	Oil Filler Cap	1
61	ST160F-1030002	Oil Filler Cap Packing	2
62	ST168F-1030007-5/16-G	Crankcase Cover	1
63	GB5789-FB8-32	Flange Bolt M8×32	6
64	ST168F-1090100	Air Cleaner Cover Nut	2
65	ST168F-1090001-G	Air Cleaner Cover	1
66	ST168F-1090200-C	Air Cleaner Element	1
67	ST168F-1090500-G	Air Cleaner Elbow	1
68	GB5789-FB6-25	Flange Bolt M6×25	2
69	ST160F-1123000	Ignition Coil	1
70	152FMD-1001007	Dowel Pin 10×16	2
71	GB5789-FB8-55	Flange Bolt M8×55	4
72	ST160F-1130004	Carburetor Washer	1
73	ST160F-1130100	Choke Lever	1
74	ST168F-2-1130000-G	Carburetor assembly	1
75	ST160F-1130003	Carburetor Packing	1
76	ST168F-1130001	Carburetor Insulator	1
77	ST160F-1130002	Insulator Packing	1
78	ST160F-1010001	Stud Bolt M6×113	2
79	ST168F-2-1010100-G	Cylinder Head	1
80	ST168F-2-1030009-G	Cylinder Head Gasket	1
81	ST168F-1040002	Intake Valve	1
82	ST168F-1040006	Exhaust Valve	1
83	ST168F-2-1040013	Valve lifter	2
84	ST168F-1030015-G	Dowel Pin 9×14	2
85	ST168F-2-1041000	Camshaft Comp	1
86	GB1099-79	Key 4×7.5×19	1
87	ST160F-1020001	Breather Tube	1
88	ST168F-1040024	Tappet Adjusting Bolt	2
89	ST160F-1020002-A	Head Over Packing	1
90	ST168F-1020100-C	Cylinder Head Cover	1
91	ST168F-1040022	Intake Rocker	1
92	ST168F-1040021	Rocker Axis	1
93	ST160F-1040008	Valve Rotator	1
94	ST160F-1040001	Intake Valve Spring Retainer	1
95	ST160F-1040007	Exhaust Valve Spring Retainer	1
96	ST160F-1040003	Valve Spring	2
97	ST160F-1124000	Spark Plug	1
98	ST168F-1040026	Lock Nut	2
99	ST168F-1040023	Exhaust Rocker	1
100	ST168F-1040026	Rocker Arm Block	1
101	ST168F-1040027	Pivot Bolt	2
102	ST168F-1040005	Push Rod	2
103	GB1667-S5-8	Screw M5×8	4
104	GB90-W-5	Washer ø5	4
105	GB93-LW-5	Lock Washer ø5	4
106	ST168F-1101100-G	Muffler Protector	1
107	ST168F-1101200-G	Muffler	1
108	GB41-N-8	Nut M8	2
109	GB90-W-8	Washer ø8	2
110	GB93-LW-8	Lock Washer ø8	2
111	ST168F-1100001-G	Muffler Packing	1
112	ST160F-1010002	Exhaust Bolt	2
113	ST168F-1080002-G	Shroud	1
114	ST168F-1050007	First Ring Set	1
	ST168F-1050006	Second Ring Set	1
	ST168F-1050200	Oil Ring Set	1
115	ST168F-2-1050005	Piston	1
116	ST168F-1050004	Piston Pin Clip	2

Specifications

Item	Part Number	Description	Qty
117	ST168F-1050003	Piston Pin	1
118	ST168F-1050100	Connecting Rod Comp	1
119	ST160F-1030005-B	Oil Filler Cap	1
120	ST160F-1070006	Fuel Filter	1
121	ST1P68F-1070006-F	Clip	1
122	GB90-W-6	Washer ø6	6
123	GB93-LW-6	Lock Washer ø6	4
124	GB5789-FB6-35	Flange Bolt M6×35	1
125	GB5789-FB6-15	Flange Bolt M6×15	4
126	GB41-N-6	Nut M6	2
127	ST168F-1040014-A	Oil Seal	2

Troubleshooting

Troubleshooting

Problem	Cause	Solution
Engine will not start	No fuel	Add fuel
	Faulty spark plug	Replace spark plug
Engine will not start; Engine starts but runs roughly	Low oil level	Fill crankcase to the proper level Place engine on a flat, level surface
	Choke in the wrong position.	Adjust choke.
	Spark plug wire loose	Attach wire to spark plug
Engine shuts down during operation	Out of fuel	Fill fuel tank
	Low oil level	Fill crankcase to the proper level. Place engine on a flat, level surface
Engine cannot supply enough power or overheating	Insufficient ventilation	Check for air restriction. Move to a well ventilated area

Warranty

CHAMPION POWER EQUIPMENT ONE YEAR LIMITED WARRANTY

Effective September 1, 2006. Replaces all undated warranties and all warranties dated before September 1, 2006.

Warranty Qualifications

Champion Power Equipment (CPE) will register this warranty upon receipt of your Warranty Registration Card and a copy of your sales receipt from one of CPE's retail locations as proof of purchase.

Please submit your warranty registration and your proof of purchase within ten (10) days of the date of purchase.

Repair/Replacement Warranty

CPE warrants to the original purchaser that the mechanical and electrical components will be free of defects in material and workmanship for a period of one (1) year from the original date of purchase (90 days for commercial & industrial use). Transportation charges on product submitted for repair or replacement under this warranty are the sole responsibility of the purchaser. This warranty only applies to the original purchaser and is not transferable.

Do not return the unit to the place of purchase

Contact CPE's Technical Service and CPE will troubleshoot any issue via phone or e-mail. If the problem is not corrected by this method, CPE will, at its option, authorize evaluation, repair or replacement of the defective part or component at a CPE Service Center. CPE will provide you with a case number for warranty service. Please keep it for future reference. Repairs or replacements without prior authorization, or at an unauthorized repair facility, will not be covered by this warranty.

Warranty Exclusions

This warranty does not cover the following repairs and equipment:

Normal Wear

Engines need periodic parts and service to perform well. This warranty does not cover repair when normal use has exhausted the life of a part or the equipment as a whole.

Installation, Use and Maintenance

This warranty will not apply to parts and/or labor if this engine is deemed to have been misused, neglected, involved in an accident, abused, loaded beyond the engine's limits, modified, installed improperly or connected incorrectly to any component. Normal maintenance such as spark plugs, air filters, adjustments, fuel system cleaning and obstruction due to buildup is not covered by this warranty.

Other Exclusions

This warranty excludes:

Cosmetic defects such as paint, decals, etc.

Wear items such as filter elements, o-rings, etc.

Accessory parts such as starting batteries, and storage covers.

Failures due to acts of God and other force majeure events beyond the manufacturer's control.

Problems cause by parts that are not original Champion Power Equipment parts.

Limits of Implied Warranty and Consequential Damage

Champion Power Equipment disclaims any obligation to cover any loss of time, use of this product, freight, or any incidental or consequential claim by anyone from using this engine. **THIS WARRANTY IS IN LIEU OF ALL OTHER WARRANTIES, EXPRESS OR IMPLIED, INCLUDING WARRANTIES OF MERCHANTABILITY OR FITNESS FOR A PARTICULAR PURPOSE**

A unit provided as an exchange will be subject to the warranty of the original unit. The length of the warranty governing the exchanged unit will remain calculated by reference to the purchase date of the original unit.

This warranty gives you certain legal rights which may change from state to state. Your state may also have other rights you may be entitled to that are not listed within this warranty.

Contact Information

Address

Champion Power Equipment, Inc.
Customer Service
10006 Santa Fe Springs Rd.
Santa Fe Springs, CA 90670

Customer Service

Mon – Fri 8:30 AM – 5:00 PM (PST/PDT)

Toll Free: 1-877-338-0999

Fax no.: 1-562-236-9429

Technical Service

Mon – Fri 8:30 AM – 5:00 PM (PST/PDT)

Toll Free: 1-877-338-0999

tech@championpowerequipment.com

Warranty

**Champion Power Equipment, Inc (CPE),
and the United States Environment Protection Agency (U.S. EPA.)
Emission Control System Warranty**

Your Champion Power Equipment (CPE) engine complies with U.S. EPA emission regulations.

YOUR WARRANTY RIGHTS AND OBLIGATIONS:

The US EPA AND CPE are pleased to explain the Federal Emission Control Systems Warranty on your 2009 small off-road engine. New engines must be designed, built and equipped, at the time of sale, to meet U.S. EPA regulations for small non-road engines. CPE must warrant the emission control system on your small off-road engine for the period of time listed below, provided there has been no abuse, neglect, unapproved modification, or improper maintenance of your small off-road engine.

Your emission control system may include parts such as the carburetor, fuel-injection system, the ignition system, catalytic converter and fuel lines. Also included may be hoses, belts, connectors and other emission related assemblies. Where a warrantable condition exists, CPE will repair your small off-road engine at no cost to you including diagnosis, parts and labor.

MANUFACTURER'S EMISSION CONTROL SYSTEM WARRANTY COVERAGE:

This emission control system is warranted for two years, subject to provisions set forth below. If, during the warranty period, emission related part on your engine is defective in materials or workmanship, the part will be repaired or replaced by CPE.

OWNER WARRANTY RESPONSIBILITIES:

As the small off-road engine owner, you are responsible for the performance of the required maintenance listed in your Owner's Manual. CPE recommends that you retain all your receipts covering maintenance on your small off-road engine, but CPE cannot deny warranty solely for the lack of receipts or for your failure to ensure the performance of all scheduled maintenance.

As the small off-road engine owner, you should however be aware that CPE may deny you warranty coverage if your small, off-road engine or a part has failed due to abuse, neglect, improper maintenance or unapproved modifications.

You are responsible for presenting your small off-road engine to an Authorized CPE service outlet, CPE dealer or CPE, Santa Fe Springs, Ca. as soon as a problem exists. The warranty repairs should be completed in a reasonable amount of time, not to exceed 30 days.

If you have any questions regarding your warranty rights and responsibilities, you should contact:

Champion Power Equipment, Inc.
Customer Service
10006 Santa Fe Springs Road
Santa Fe Springs, CA 90670
Tel: 1-877-338-0999

The emission warranty is a defects warranty. Defects are judged on normal engine performance. The warranty is not related to an in-use emission test.

EMISSION CONTROL SYSTEM WARRANTY

The following are specific provisions relative to your Emission Control System Warranty Coverage.

Emission Control System Warranty (ECS Warranty) for 1997 and later model year engines):

1. APPLICABILITY: This warranty shall apply to 1997 and later model year engines). The ECS Warranty Period shall begin on the date the new engine or equipment is delivered to its original, end-use purchaser, and shall continue for 24 consecutive months thereafter.

2. GENERAL EMISSIONS WARRANTY COVERAGE

CPE warrants to the original, end-use purchaser of the new engine or equipment and to each subsequent purchaser that each of its small off-road engines is:

- a. Designed, built and equipped so as to conform at the time of sale with applicable regulations under section 213 of the Clean Air Act, as amended, 42 U.S.C. 7401 et seq.
- b. Free from defects in materials and workmanship that cause the failure of a warranted part to be identical in all material respects to the part as described in the engine manufacturer's application for certification for a period of two years.

3. THE WARRANTY ON EMISSION-RELATED PARTS WILL BE INTERPRETED AS FOLLOWS:

a. Any warranted part that is not scheduled for replacement as required maintenance in the Owners Manual shall be warranted for the ECS Warranty Period. If any such part fails during the ECS Warranty Period, it shall be repaired or replaced by CPE according to Subsection "d" below. Any such part repaired or replaced under the ECS Warranty shall be warranted for any remainder of the ECS Warranty Period.

b. Any warranted, emissions-related part which is scheduled only for regular inspection as specified in the Owners Manual shall be warranted for the ECS Warranty Period. A statement in such written instructions to the effect of "repair or replace as necessary", shall not reduce the ECS Warranty Period. Any such part repaired or replaced under the ECS Warranty shall be warranted for the remainder of the ECS Warranty Period.

c. Any warranted, emissions-related part which is scheduled for replacement as required maintenance in the Owner's Manual shall be warranted for the period of time prior to the first scheduled replacement point for that part. If the part fails prior to the first scheduled replacement, the part shall be repaired or replaced by CPE according to Subsection "d" below. Any such emissions-related part repaired or replaced under the ECS Warranty, shall be warranted for the remainder of the ECS Warranty Period prior to the first scheduled replacement point for such emissions-related part.

d. Repair or replacement of any warranted, emissions-related part under this ECS Warranty shall be performed at no charge to the owner at a CPE Authorized Service Outlet.

e. The owner shall not be charged for diagnostic labor which leads to the determination that a part covered by the ECS Warranty is in fact defective, provided that such diagnostic work is performed at a CPE Authorized Service Outlet.

f. CPE shall be liable for damages to other original engine components or approved modifications proximately caused by a failure under warranty of an emission-related part covered by the ECS Warranty.

g. Throughout the ECS Warranty Period, CPE shall maintain a supply of warranted emission-related parts sufficient to meet the expected demand for such emission-related parts.

h. Any CPE Authorized and approved emission-related replacement part may be used in the performance of any ECS Warranty maintenance or repair and will be provided without charge to the owner. Such use shall not reduce CPE's warranty obligation.

i. Unapproved add-on or modified parts may not be used to modify or repair a CPE engine. Such use voids this ECS Warranty and shall be sufficient grounds for disallowing an ECS Warranty claim. CPE shall not be liable hereunder for failures of any warranted parts of a CPE engine caused by the use of such an unapproved add-on or modified part.

Warranty

EMISSION-RELATED PARTS INCLUDE THE FOLLOWING: (using those portions of the list applicable to the engine)

Systems covered by this warranty	Parts Description
Fuel Metering System	Fuel regulator, Carburetor and internal parts
Air Induction System	Air cleaner, Intake manifold
Ignition System	Spark plug and parts, Magneto ignition system
Exhaust System	Exhaust manifold, catalytic converter
Miscellaneous Parts	Tubing, Fittings, Seals, Gaskets, and Clamps associated with these listed systems

TO OBTAIN WARRANTY SERVICE:

You must take your CPE engine or the product on which it is installed, along with your warranty registration card or other proof of original purchase date, at your expense, to any Champion Power Equipment dealer who is authorized by Champion Power Equipment, Inc. to sell and service that CPE product during his normal business hours. Claims for repair or adjustment found to be caused solely by defects in material or workmanship will not be denied because the engine was not properly maintained and used.

If you have any questions regarding your warranty rights and responsibilities, or to obtain warranty service, please write or call the Customer service of Champion Power Equipment, Inc.

**Champion Power Equipment, Inc.
10006 Santa Fe Springs Road
Santa Fe Springs, CA 90670
1-877-338-0999
Attn: Customer Service**

Notes