



OWNER'S MANUAL & OPERATING INSTRUCTIONS



# BIKE CARRIER

**1 YEAR**  
LIMITED WARRANTY

MODEL NUMBER  
**50063**

**SAVE THESE INSTRUCTIONS**  
Important Safety Instructions  
are included in this manual.

MADE IN CHINA  
REV 50063-20110126

10006 Santa Fe Springs Road  
Santa Fe Springs CA 90670  
USA / 1-877-338-0999  
[www.championpowerequipment.com](http://www.championpowerequipment.com)

**Have questions or need assistance?**

*Do not return this product to the store!*

**WE ARE HERE TO HELP!**

Visit our website:

**[www.championpowerequipment.com](http://www.championpowerequipment.com)**

for more info:

- Product Info & Updates
- Tech Bulletins
- Frequently Asked Questions
- Product Registration

– or –

Call our Customer Care Team Toll-Free at:

**1-877-338-0999**

## Introduction

Congratulations on your purchase of a Champion Power Equipment adjustable bike carrier. With proper use and maintenance, this bike carrier will bring years of satisfying service.

→ [www.championpowerequipment.com](http://www.championpowerequipment.com)

### NOTE

If you have questions regarding your bike carrier, we can help. Please call our help line at **1-877-338-0999**

## SAFETY RULES

### WARNING

Read this manual thoroughly before installing and using your bike carrier. Failure to follow instructions could result in serious injury to person or property.

### WARNING

This rack is designed to attach securely to most automobile receiver hitches. Due to variations in automobile design and utility, we cannot guarantee this product will fit all vehicles. It is your responsibility to ensure the safe and proper use of this product.

This rack is designed for use on passenger cars, trucks and SUV's with appropriate receiver capacity. Improper use and attachment of the rack to your vehicle may be hazardous to your bicycles, vehicles or other vehicles driving behind you.

### WARNING

DO NOT exceed the rated capacity of this bike carrier. Load no more than 4 bicycles, weighing less than 200 lbs total.

DO NOT use this bike carrier for transporting or carrying other items or materials besides bicycles.

### CAUTION

ALWAYS secure your bicycles to the rack using the frame cradles and straps. Additional rope, shock cords, or cable locks may be used for additional security and stability.

If a strap appears worn or frayed, replace it immediately.

Check straps and cradles regularly during use. It's a good practice to stop your vehicle after 500 feet and check the security of the mounted bicycles.

This bike carrier was not constructed to protect bicycles from severe abuse in off-highway driving conditions. Bumpy roads may cause mounted bicycles to move and shift in transit, resulting in property damage.

DO NOT let bicycle tires hang near the exhaust pipe of your vehicle. Hot exhaust may cause damage to tires.

### WARNING

The Bicycle Carrier should not be used for TOWING or any pulling purpose. Not for use behind a 5th wheel or travel trailer.

# ASSEMBLY

This product ships from our factory partially assembled. Clear away a dry clean space on the floor or a table to assemble the bike carrier.

Remove all contents from the packing box and locate all components.

1. Insert the square hitch tube (1) into the receiver tube of your vehicle.
2. Insert the support pole (10) into the square hitch tube (1) making sure to align bolt holes.

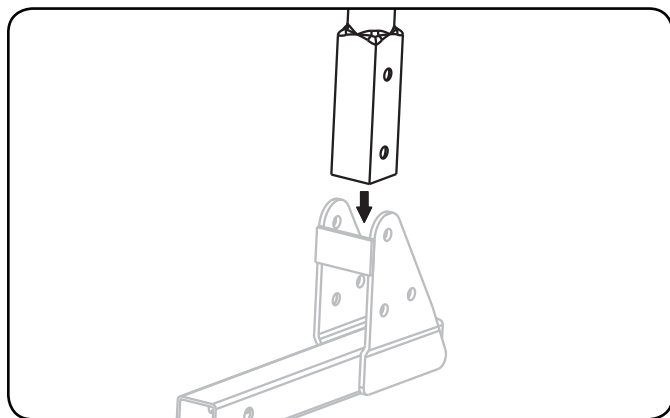

3. Secure the support pole (10) to the square hitch tube (1) using an M12 x 90 bolt (2), three M12 washers (3) and M12 lock nut (4).

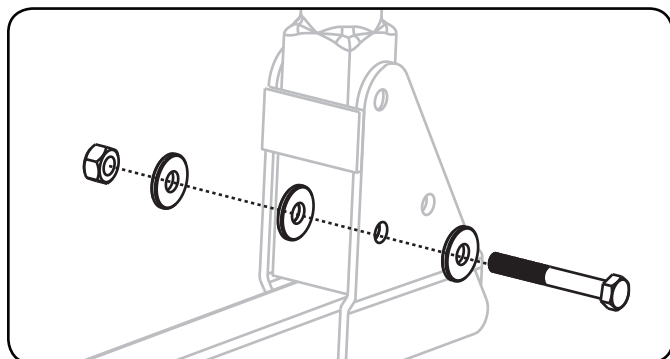

4. Secure the position of the support pole with the D-Pin (20).

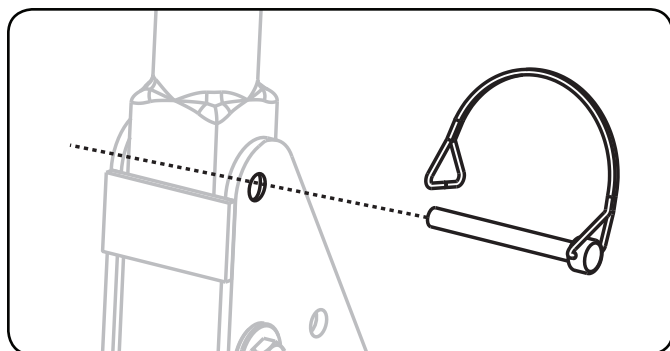

5. Install the folding stop by placing the M12 x 90 bolt (2) through the black rubber pipe (9) and securing with two M12 washers (3) and M12 lock nut (4).

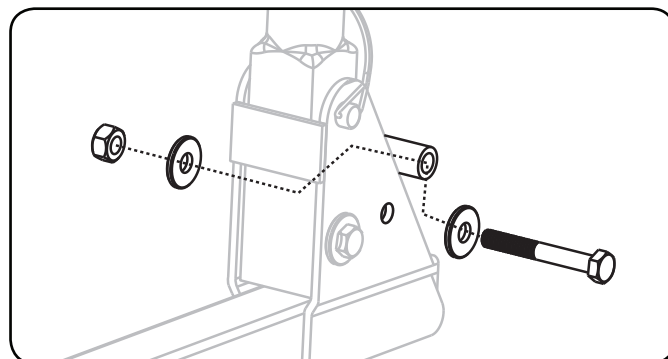

6. Slide the horizontal bar (13) over the support pole (10) and secure with M8 x 60 bolts and M8 lock nut.

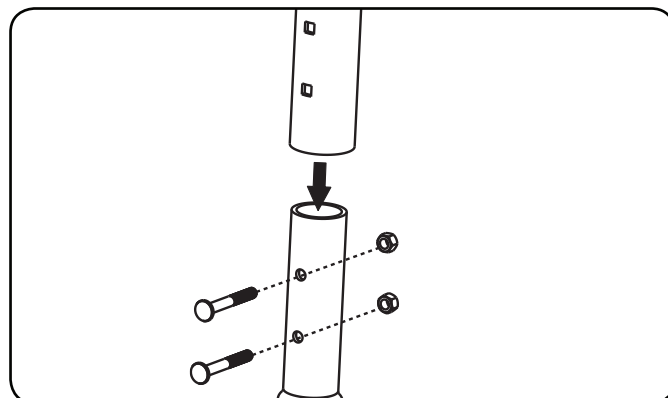

## Assembling the 1/4 Inch Adapter

For vehicles with a 1/4" hitch receiver, please use the 1/4" adapter supplied with this bike carrier.

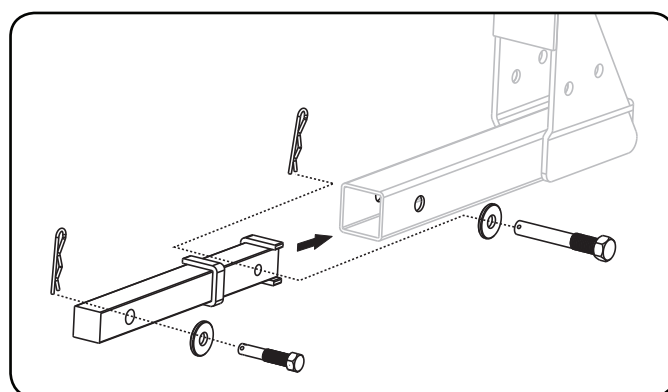

1. Align as shown in the above image and insert the 1/4" square hitch adapter (19) into the 2" square hitch tube (1) on the bike carrier.
2. Secure the adapter to the hitch tube using the M16 x 80 bolt (8), M16 washer (7) and R-Pin (5).  
**Note:** Bolt must be inserted in direction shown above.
3. Slide the 1/4" square hitch adapter into the 1/4" receiver tube of your vehicle.
4. Secure the bike carrier to your vehicle using an M12 x 58 bolt (6), M12 washer (12) and R-Pin (5).

Now that your rack is assembled, follow these instructions below for safe and proper use.

### NOTE

Before every use, verify that all components are in good working order. Secure and tighten all hardware before mounting bicycles to the rack.

1. Slide the square hitch tube into the receiver tube of your vehicle. Secure the hitch with the M16 x 80 bolt (8), M16 washer (7) and R pin (5) provided.
2. Lift a bicycle up to the horizontal bar of the rack and place the frame of the bicycle onto the cradle assembly (16). See image below.

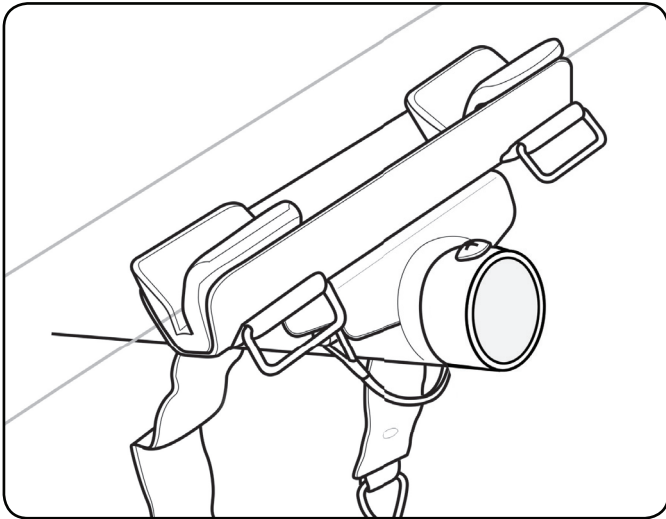

3. Take the cradle strap and wrap it over the frame of the bicycle, then through the ring on cradle. See image below.

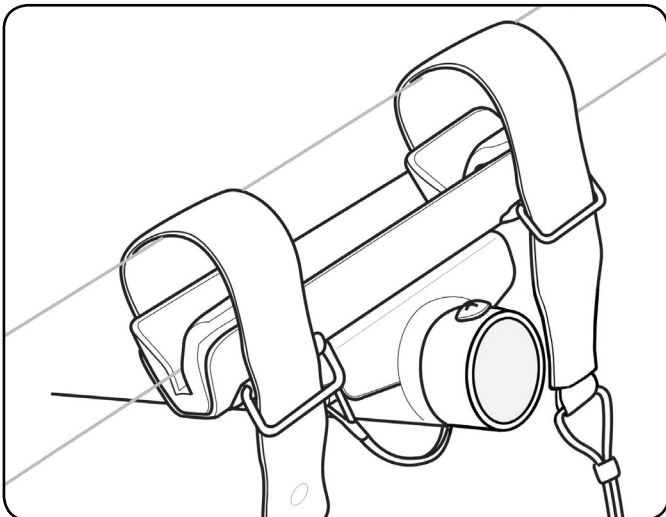

4. Double the strap over the ring and wrap back around the frame of the bicycle tightly. Wrap all the way around until the end of strap links with the tab. See image below.

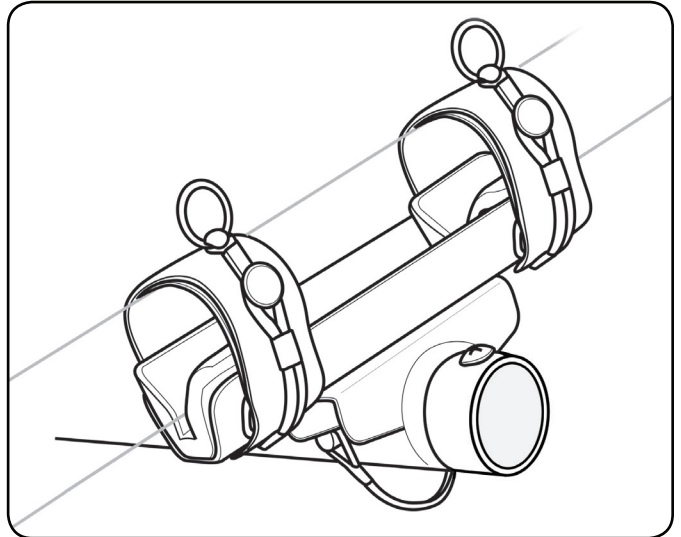

5. Repeat actions for additional bicycles.
6. Depending on the style of your bicycle frame you may need to adjust the angle of the cradle assembly. You may also need to adjust the angle of the cradle assembly to accommodate multiple bicycles. Simply remove the locking pin (14) and rotate the cradle assembly. Re-insert the locking pin to secure.

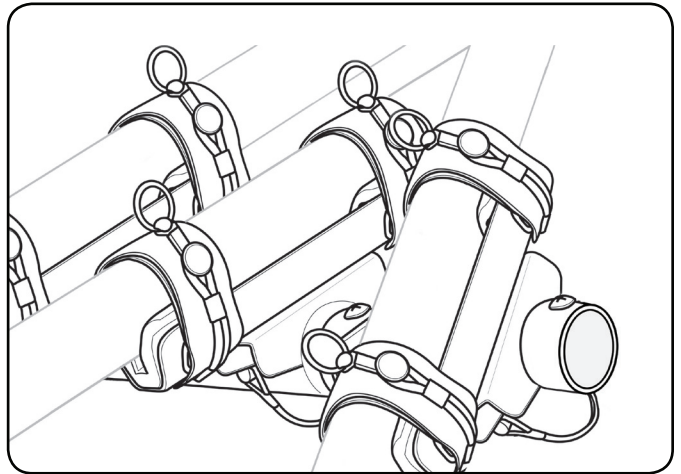

7. Use the strap located on the support bar to loop through bicycle wheels to prevent movement during transit.
8. Make sure all bicycles are secure and stable before moving the vehicle.

# SPECIFICATIONS

## Parts Diagram & List

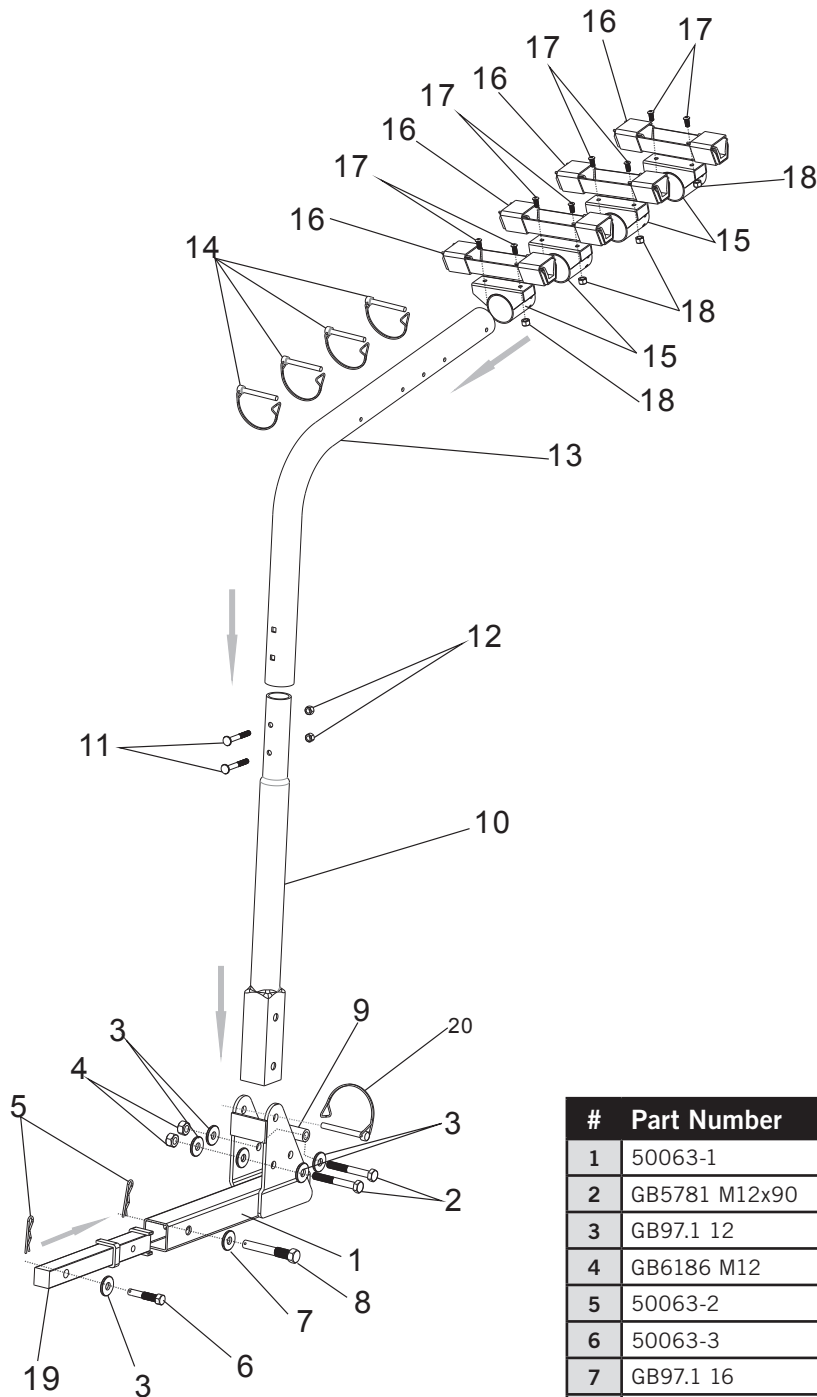

#	Part Number	Description	Qty
1	50063-1	2"X2" Square Hitch	1
2	GB5781 M12x90	Bolt M12X90	2
3	GB97.1 12	Flat Washer M12	5
4	GB6186 M12	Lock Nut M12	2
5	50063-2	R-Pin	2
6	50063-3	Bolt M12X58	1
7	GB97.1 16	Flat Washer M16	1
8	50063-4	Bolt M16X80	1
9	50063-5	Black Rubber Pipe	1
10	50063-6	Support Pole	1
11	GB/T794 M8x60	Bolt M8X60	2
12	GB6186 M8	Lock Nut M8	2
13	50063-7	Horizontal Bar	1
14	50063-8	D-Pin 8Mm	4
15	50063-9	Cradle Supporter	4
16	50063-10	Cradle Assembly	4
17	GB/T820 M6x12	Screw M6X12	8
18	GB6186 M6	Lock Nut M6	8
19	50063-11	Adapter 2"-1.25"	1
20	50063-12	D-Pin 12Mm	1

**WARRANTY****CHAMPION POWER EQUIPMENT  
1 YEAR LIMITED WARRANTY**

Effective September 1, 2006. Replaces all undated warranties and all warranties dated before September 1, 2006.

**Warranty Qualifications**

Champion Power Equipment (CPE) will register this warranty upon receipt of your Warranty Registration Card and a copy of your sales receipt from one of CPE's retail locations as proof of purchase.

Please submit your warranty registration and your proof of purchase within ten (10) days of the date of purchase.

**Repair/Replacement Warranty**

CPE warrants to the original purchaser that the components will be free of defects in material and workmanship for a period of one (1) year from the original date of purchase. Transportation charges on product submitted for repair or replacement under this warranty are the sole responsibility of the purchaser.

This warranty only applies to the original purchaser and is not transferable.

**Do Not Return The Unit To The Place Of Purchase**

Contact CPE's Technical Service and CPE will troubleshoot any issue via phone or e-mail. If the problem is not corrected by this method, CPE will, at its option, authorize evaluation, repair or replacement of the defective part or component at a CPE Service Center. CPE will provide you with a case number for warranty service. Please keep it for future reference. Repairs or replacements without prior authorization, or at an unauthorized repair facility, will not be covered by this warranty.

**Warranty Exclusions**

This warranty does not cover the following repairs and equipment:

**Normal Wear**

This warranty does not cover repair when normal use has exhausted the life of a part or the equipment as a whole.

**Installation, Use and Maintenance**

This warranty will not apply to parts and/or labor if this bicycle rack is deemed to have been misused, neglected, involved in an accident, abused, loaded beyond the rack's limits, modified, or installed improperly.

**Other Exclusions**

This warranty excludes: Cosmetic defects such as paint, decals, etc. Failures due to acts of God and other force majeure events beyond the manufacturer's control. Problems caused by parts that are not original Champion Power Equipment parts.

**Limits of Implied Warranty and Consequential Damage**

Champion Power Equipment disclaims any obligation to cover any loss of time, use of this product, freight, or any incidental or consequential claim by anyone from using this bike carrier. THIS WARRANTY IS IN LIEU OF ALL OTHER WARRANTIES, EXPRESS OR IMPLIED, INCLUDING WARRANTIES OF MERCHANTABILITY OR FITNESS FOR A PARTICULAR PURPOSE.

A unit provided as an exchange will be subject to the warranty of the original unit. The length of the warranty governing the exchanged unit will remain calculated by reference to the purchase date of the original unit.

This warranty gives you certain legal rights which may change from province to province or state to state. Your state/province may also have other rights you may be entitled to that are not listed within this warranty.

**Contact Information****Address**

Champion Power Equipment, Inc.  
Customer Service  
10006 Santa Fe Springs Rd.  
Santa Fe Springs, CA 90670  
[www.championpowerequipment.com](http://www.championpowerequipment.com)

**Customer Service**

Mon – Fri 8:30 AM – 5:00 PM (PST/PDT)  
Toll Free: 1-877-338-0999  
Fax no.: 1-562-236-9429

**Technical Service**

Mon – Fri 8:30 AM – 5:00 PM (PST/PDT)  
Toll Free: 1-877-338-0999  
[tech@championpowerequipment.com](mailto:tech@championpowerequipment.com)