

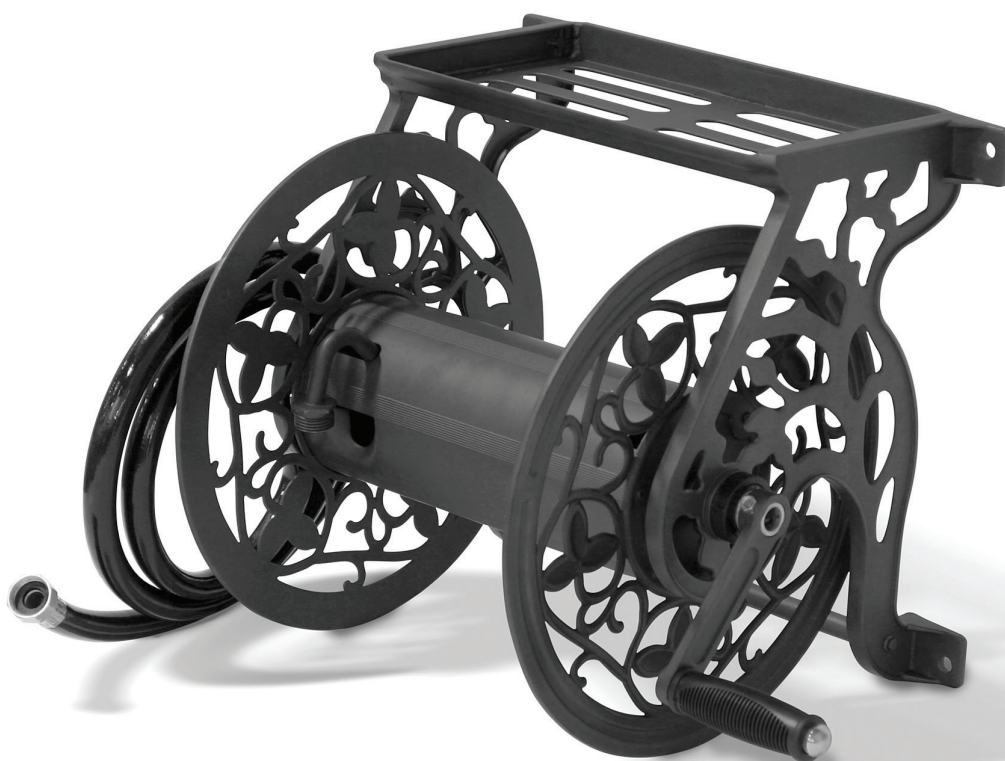

OWNER'S MANUAL  
& OPERATING INSTRUCTIONS



# METAL HOSE REEL



MODEL NUMBER  
**50052**

**SAVE THESE INSTRUCTIONS**  
Important safety instructions  
are included in this manual.

MADE IN CHINA  
REV 50052-20121025

10006 Santa Fe Springs Road  
Santa Fe Springs CA 90670  
USA / 1-877-338-0999  
[www.championpowerequipment.com](http://www.championpowerequipment.com)

**Have questions or need assistance?**

*Do not return this product to the store!*

**WE ARE HERE TO HELP!**

Visit our website:

**[www.championpowerequipment.com](http://www.championpowerequipment.com)**

for more info:

- Product Info and Updates
- Tech Bulletins
- Frequently Asked Questions
- Product Registration

– or –

Call our Customer Care Team Toll-Free at:

**1-877-338-0999**



# METAL HOSE REEL

## TABLE OF CONTENTS

---

<b>Manual Conventions</b> . . . . .	<b>1</b>
<b>Introduction</b> . . . . .	<b>2</b>
Before You Begin . . . . .	2
<b>Parts</b> . . . . .	<b>3</b>
<b>Assembly</b> . . . . .	<b>4</b>
Mounting to Concrete or Brick Masonry Construction . . . . .	4
Mounting to Flat Wood Frame Construction . . . . .	4
Handle Assembly . . . . .	4
Attaching the Leader Hose . . . . .	4
<b>Specifications</b> . . . . .	<b>5</b>
Parts Diagram . . . . .	5
Parts List . . . . .	6
<b>Warranty</b> . . . . .	<b>7</b>
Warranty Qualifications . . . . .	7
Repair/Replacement Warranty . . . . .	7
Do Not Return The Unit To The Place Of Purchase . . . . .	7
Warranty Exclusions . . . . .	7
Normal Wear . . . . .	7
Installation, Use and Maintenance . . . . .	7
Other Exclusions . . . . .	7
Limits of Implied Warranty and Consequential Damage . . . . .	7
Contact Information . . . . .	7
Address . . . . .	7
Customer Service . . . . .	7
Technical Service . . . . .	7

# MANUAL CONVENTIONS

---

This manual uses the following symbols to help differentiate between different kinds of information. The safety symbol is used with a key word to alert you to potential hazards in operating and owning power equipment.

Follow all safety messages to avoid or reduce the risk of serious injury or death.

## **WARNING**

WARNING indicates a potentially hazardous situation which, if not avoided, **could** result in death or serious injury.

## **CAUTION**

CAUTION indicates a potentially hazardous situation which, if not avoided, **may** result in minor or moderate injury.

## **NOTE**

If you have questions regarding your hose reel, we can help. Please call our help line at **1-877-338-0999**

**Before You Begin**

This product has been packaged to ensure it arrives in best possible condition. Please be careful when unpacking. Read instructions prior to assembly. This kit contains parts that can be damaged if incorrectly assembled. Please follow instructions. Champion Power Equipment is not responsible for replacing parts damaged due to incorrect assembly.

**NOTE**

Do not completely tighten bolts until assembly is completed. For easier assembly, we recommend that two people assemble this product.

**WARNING**

The coupling contains lead, a chemical known to the state of California to cause cancer and birth defects or other reproductive harm.

WASH HANDS after handling.

This hose is not for drinking water use.

**CAUTION**

Please consider carefully the appropriate method to be used in mounting this hose reel. Hardware is included for your convenience, but may not be suitable for all mounting conditions. Some surfaces like vinyl siding or stucco may require special considerations or additional hardware. Improper mounting can cause personal injury or property damage. If you are unsure, contact a home improvement professional

Record the model and serial numbers as well as date and place of purchase for future reference. Have this information available when ordering parts and when making technical or warranty inquiries.

<b>Champion Power Equipment Support</b>
<b>1-877-338-0999</b>
Model Number
<b>50052</b>
Serial Number
Date of Purchase
Purchase Location

## PARTS

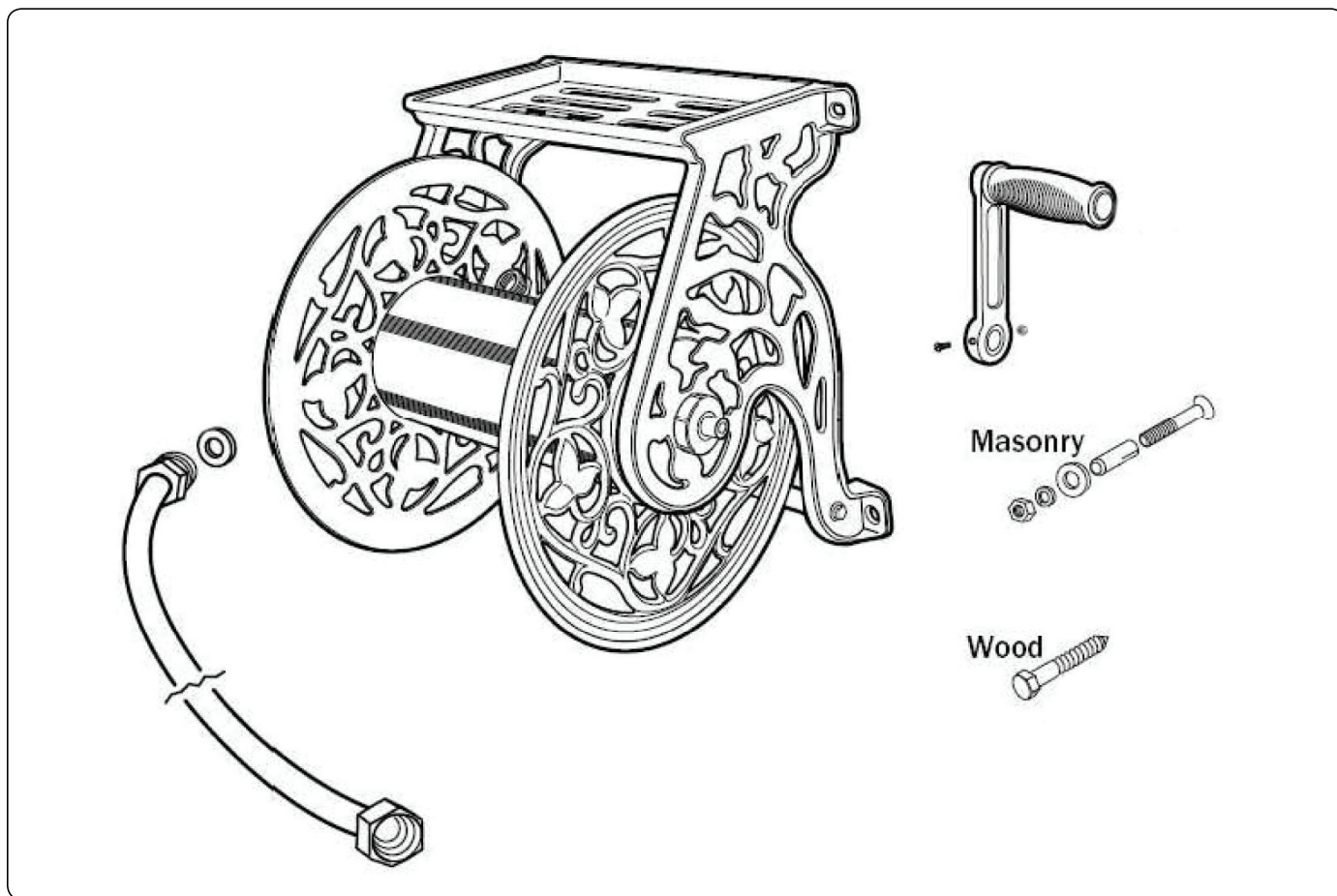
**Parts Included**

- Hose Reel . . . . . 1
- 2 m (6.5 ft.) Leader Hose . . . . . 1
- Seal Washer . . . . . 2
- Self Tapping Screw . . . . . 4
- Plastic Expand Sleeve . . . . . 4
- Inlet Base . . . . . 1
- Inlet Clip . . . . . 1
- Rewind Handle . . . . . 1

**Tools Required (Not Included)**

- Powered hand drill or hammer drill with  
13 mm (1/2 in.) masonry drill bit or 6 mm (1/4 in.)  
standard drill bit
- Small hammer or mallet
- 10 mm socket or wrench (2)

**Replacement Parts**

For replacement parts, contact:

**Address**

Champion Power Equipment, Inc.  
Customer Service  
10006 Santa Fe Springs Rd.  
Santa Fe Springs, CA 90670  
[www.championpowerequipment.com](http://www.championpowerequipment.com)

**Customer Service**

Mon – Fri 8:30 AM – 5:00 PM (PST/PDT)  
Toll Free: 1-877-338-0999  
Fax no.: 1-562-236-9429

**Technical Service**

Mon – Fri 8:30 AM – 5:00 PM (PST/PDT)  
Toll Free: 1-877-338-0999  
[tech@championpowerequipment.com](mailto:tech@championpowerequipment.com)

**NOTE**

Other components may be identified by part numbers marked on the part.  
Anchors for masonry application only.

**NOTE**

Carefully remove all parts from the packing box. Locate all hardware and components before installation.

**Mounting on masonry or brick****Tools Required (Not Included):**

- Powered hand drill or hammer drill with 13 mm (1/2 in.) masonry drill bit
- Small hammer or mallet
- 10 mm socket or wrench

**Instructions:**

1. Place the hose reel on the mounting surface and use a pencil to mark the location of the 4 mounting holes.
2. Using an electric drill, drill holes with a 13 mm (1/2 in.) diameter masonry bit no deeper than 4.1 cm (1 5/8 in.)
3. Insert the masonry wall anchors into the anchor sleeves. Insert the anchor and sleeve together into the drilled holes on the wall. The anchor sleeve must be inserted all the way into the wall. These may need to be seated by tapping with the mallet. Repeat for all 4 holes. See Diagram below.

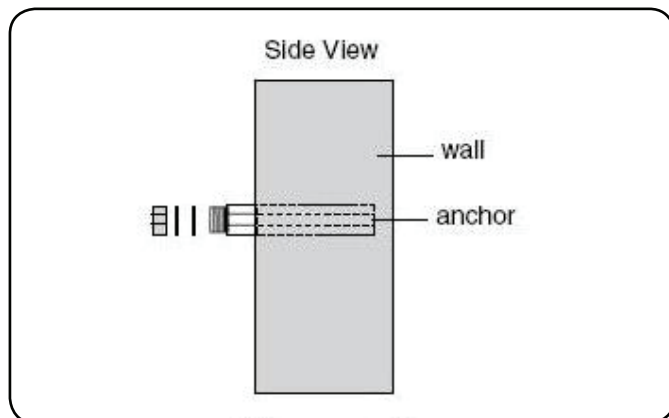

4. Place the reel onto the masonry wall anchors.
5. Place a flat washer, lock washer and nut on each masonry wall anchor. Tighten to secure.

**Mounting to Flat Wood Frame Construction****Tools Required (Not Included):**

- 10 mm socket or wrench
- Powered hand drill with 1/4 in. (6 mm) standard drill bit

**Instructions:**

1. Place the hose reel on the mounting surface and use a pencil to mark the location of the 4 mounting holes.
2. Using an electric drill, drill pilot holes 6 mm (1/4 in.) in diameter, 5 cm (2 in.) deep.
3. Place the reel on the wall, aligning the mounting holes with the pilot holes in the wall. Secure with 4 lag screws provided.

**! CAUTION**

To prevent damage or injury, be sure to verify that holes align with stud locations in the wall.

**NOTE**

Mounting on other materials may require other hardware.

**Handle Assembly****Instructions:**

1. Requires two 10 mm wrenches to assemble (not included). Place the handle on the hub of the hose reel and secure with bolt and lock nut.

**Attaching the Leader Hose****Instructions:**

1. Verify placement of rubber washers in leader hose couplings.
2. Install one end of the leader hose to the water inlet tightening the threaded coupling by hand.

# SPECIFICATIONS

## Parts Diagram

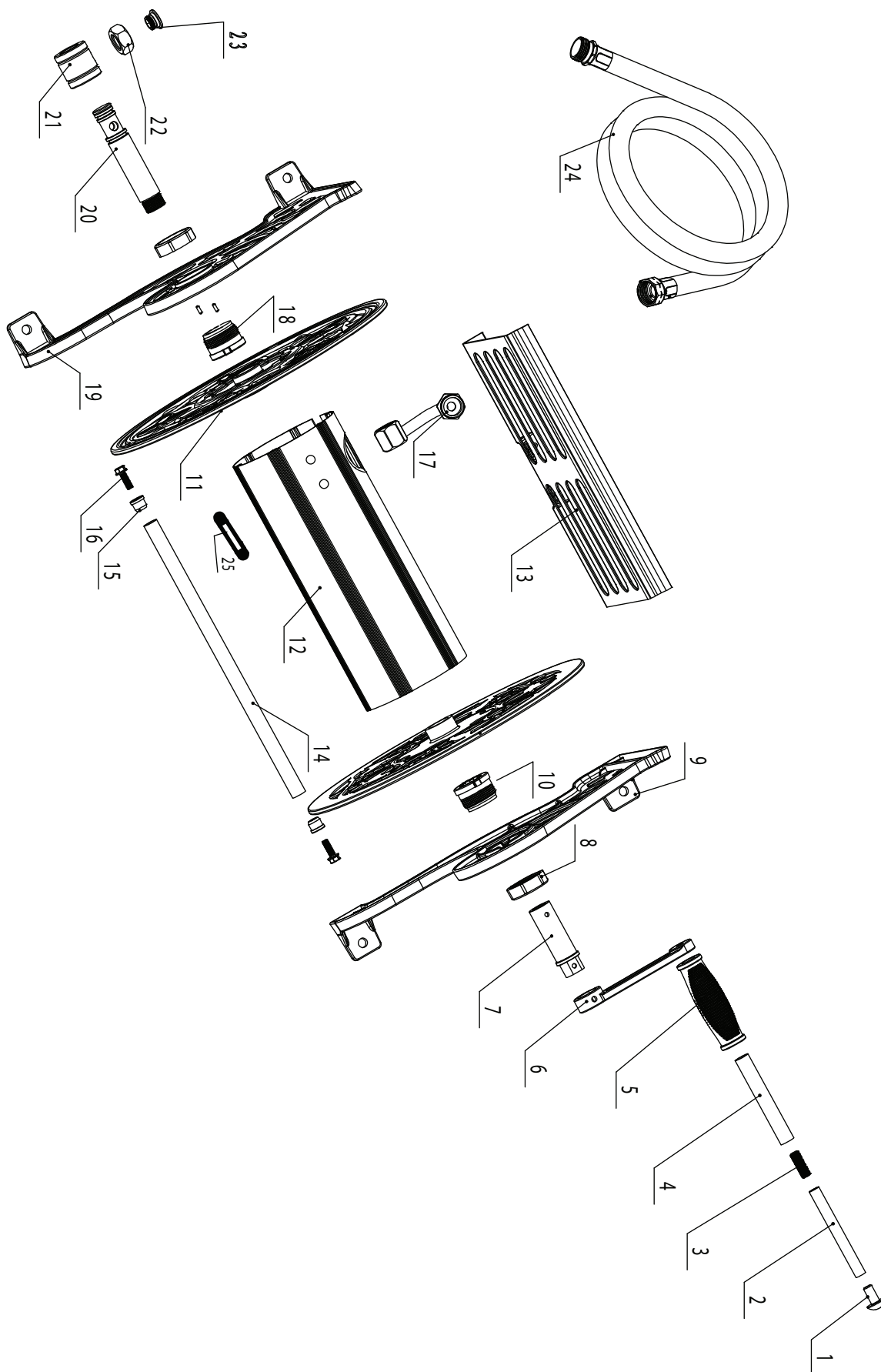



#	Part Number	Description	Qty
1	50054-01	Rivet	1
2	50054-02	Crank Inner Tube	1
3	50054-03	Crank Bolt	1
4	50054-04	Crank Outer Tube	1
5	50054-05	Crank Soft Tube	1
6	50054-06	Crank	1
7	50054-07	Short Alex	1
8	50054-08	Swivel Cover	1
9	50054-09	Right Frame	1
10	50054-10	Right Plastic Sleeve	1
11	50054-11	Right/Left Basket	2
12	50054-12	Hub	1
13	50054-13	Top Tray	1
14	50054-14	Support Tube	1
15	50054-15	End Nut (Support Tube)	2
16	50054-16	End Screw (Support Tube)	2

#	Part Number	Description	Qty
17	50054-17	Outlet Fitting	1
18	50054-18	Left Plastic Bearing	1
19	50054-19	Left Frame	1
20	50054-20	Long Alex	1
21	50054-21	Sleeve	1
22	50054-22	Inlet Brass Nut	1
23	50054-23	Inlet Brass Screw	1
24	50054-24	Leader Hose	1
25	50054-25	Hose Press	1
26	50054-26	10 mm x 30 mm Wall Anchors	4
27	50054-27	Anchor Sleeves	4
28	50054-28	10 mm Washer	4
29	50054-29	10 mm Lock Washer	4
30	50054-30	10 mm Nuts	4
31	50054-31	Lag Screw	4

# WARRANTY

## WARRANTY

CHAMPION POWER EQUIPMENT  
2-YEAR LIMITED WARRANTY

### Warranty Qualifications

Champion Power Equipment (CPE) will register this warranty upon receipt of your Warranty Registration Card and a copy of your sales receipt from one of CPE's retail locations as proof of purchase.

Please submit your warranty registration and your proof of purchase within ten (10) days of the date of purchase.

### Limited Repair/Replacement Warranty

CPE warrants to the original purchaser that the components will be free of defects in material and workmanship for a period of two (2) years from the original date of purchase.

Transportation charges on product submitted for repair or replacement under this warranty are the sole responsibility of the purchaser. This warranty applies only to the original purchaser and is not transferable.

### Do Not Return The Unit To The Place Of Purchase

Contact CPE's Technical Service and CPE will troubleshoot any issue via phone or e-mail. If the problem is not corrected by this method, CPE will, at its option, authorize evaluation, repair or replacement of the defective part or component at a CPE Service Centre. CPE will provide you with a case number for warranty service. Please keep it for future reference. Repairs or replacements without prior authorization, or at an unauthorized repair facility, will not be covered by this warranty.

### Warranty Exclusions

This warranty does not cover the following repairs and equipment:

#### Normal Wear

This warranty does not cover repair when normal use has exhausted the life of a part or the equipment as a whole.

#### Installation, Use and Maintenance

This warranty will not apply to parts and/or labour if this hose reel is deemed to have been misused, neglected, involved in an accident, abused, modified, installed improperly or connected incorrectly to any hose kit.

### Other Exclusions

This warranty excludes:

- Cosmetic defects such as paint, decals, etc.
- Failures due to acts of God and other force majeure events beyond the manufacturer's control.
- Problems cause by parts that are not original Champion Power Equipment parts.

### Limits of Implied Warranty and Consequential Damage

Champion Power Equipment disclaims any obligation to cover any loss of time, use of this product, freight, or any incidental or consequential claim by anyone from using this hose reel.

THIS WARRANTY IS IN LIEU OF ALL OTHER WARRANTIES, EXPRESS OR IMPLIED, INCLUDING WARRANTIES OF MERCHANTABILITY OR FITNESS FOR A PARTICULAR PURPOSE.

A unit provided as an exchange will be subject to the warranty of the original unit. The length of the warranty governing the exchanged unit will remain calculated by reference to the purchase date of the original unit. This warranty gives you certain legal rights which may change from province to province. Your state may also have other rights you may be entitled to that are not listed within this warranty.

### Contact Information

#### Address

Champion Power Equipment, Inc.  
Customer Service  
10006 Santa Fe Springs Rd.  
Santa Fe Springs, CA 90670  
[www.championpowerequipment.com](http://www.championpowerequipment.com)

#### Customer Service

Mon – Fri 8:30 AM – 5:00 PM (PST/PDT)  
Toll Free: 1-877-338-0999  
Fax no.: 1-562-236-9429

#### Technical Service

Mon – Fri 8:30 AM – 5:00 PM (PST/PDT)  
Toll Free: 1-877-338-0999  
[tech@championpowerequipment.com](mailto:tech@championpowerequipment.com)