

CHAMPION

POWER EQUIPMENT™

50028
Rev 50028-20080515



Owner's Manual and Operating Instructions



UNIVERSAL MOUNT

ATV BASKETS

Congratulations on your purchase of a Champion Power Equipment ATV Basket. CPE designs and builds these baskets to strict specifications. With proper use and maintenance, it will bring years of satisfying service.

Every effort has been made to ensure the accuracy and completeness of the information in this manual. We reserve the right to change, alter and/or improve the product and this document at any time without prior notice

 **WARNING**

Read, study and follow all instructions before using these devices. Failure to heed these instructions may result in personal injury and/or property damage.

 **WARNING**

When loading your basket do not exceed the ATV manufacturers rack weight carrying capacity.

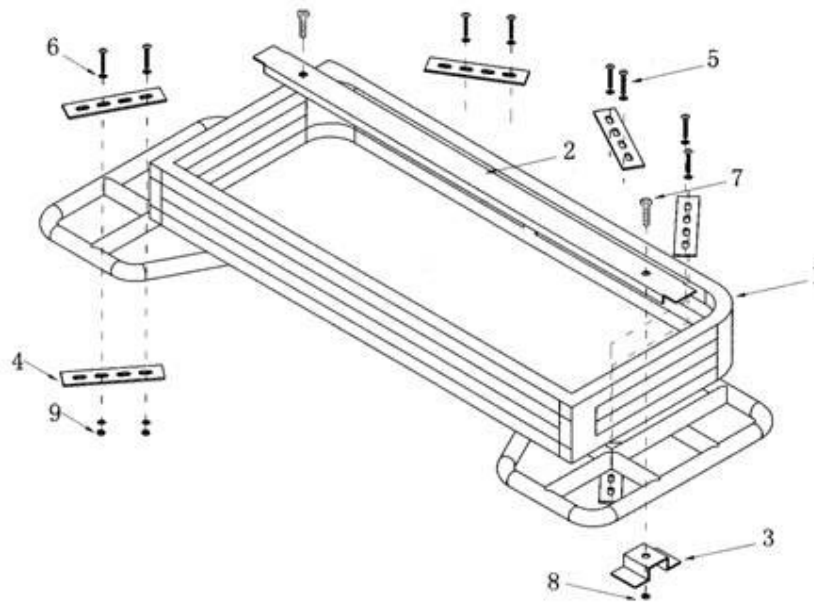
Front Basket**Assembly Instructions**

1. If mounting the basket on an ATV rack without an upright, attach filler clamps to the basket. The long clamp will lie over the opening with the flat side up, as shown. The two smaller clamps are installed from below the basket. Secure with (2) M6x15 bolts and lock nuts.
2. Center the basket over the front rack of the ATV. Note, depending on the type and size of rack upright, it may have to be removed before the basket can be installed.
3. Place self-adhesive pads (included) between basket and ATV rack to prevent scratching.

No.	Part #	Description	Qty.
1	50028-01	Front Basket	1
2	50028-02	Filler Clamp	1
3	50028-03	Filler Clamp	2
4	50028-04	Mounting Brackets	8
5	50028-05	Bolts M6x75	8
6	50028-06	SAE Washer Ø6	8
7	50028-07	Bolt M6x15	2
8	50028-08	Lock Nut M6	2
9	50028-09	Nylon Nut M6	8

Drop Basket

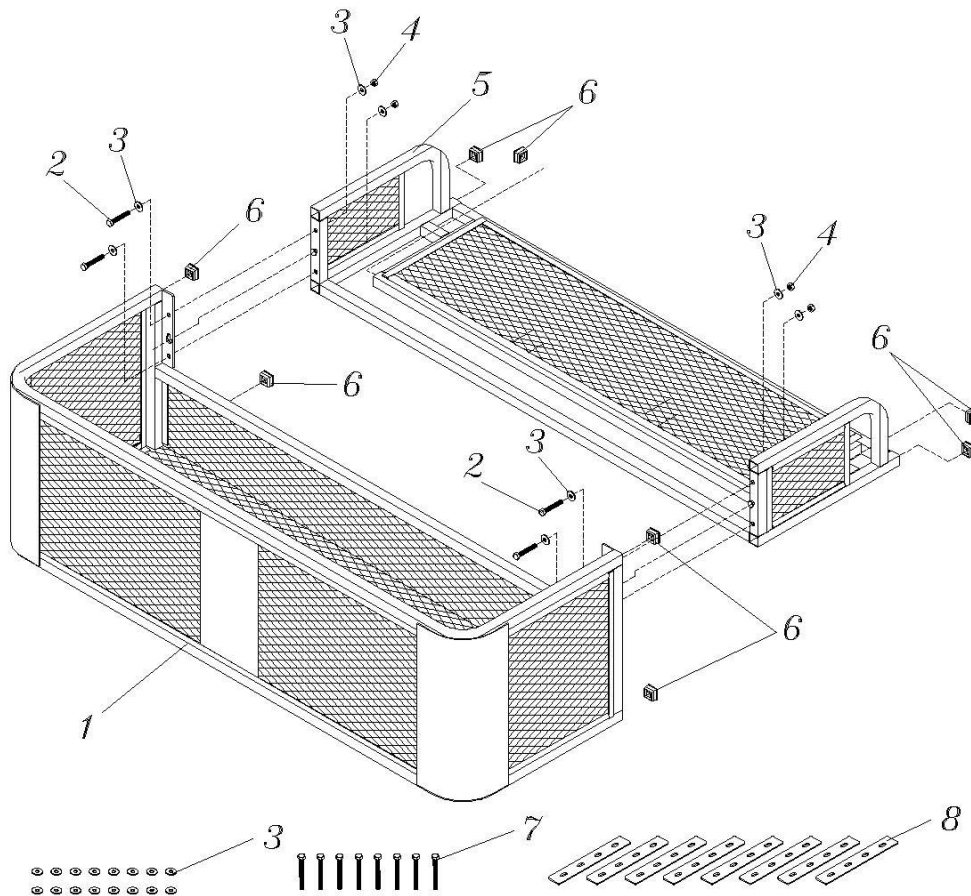

Assembly Instructions

1. Align the pin on the small basket with the hole on the large basket (Image A on the right)
2. Push down the Big Basket so that the baskets lock in place (Image B)
3. Secure the two baskets together using the hardware provided. M6x40 (#2), Washers Ø6 (#3) and Lock Nut M6 (#4).

Repeat action on both sides.

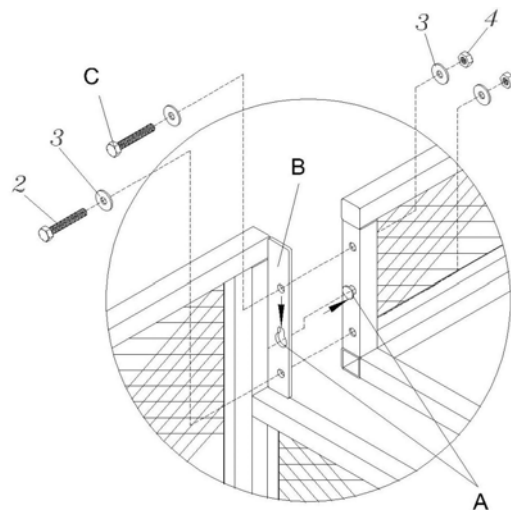

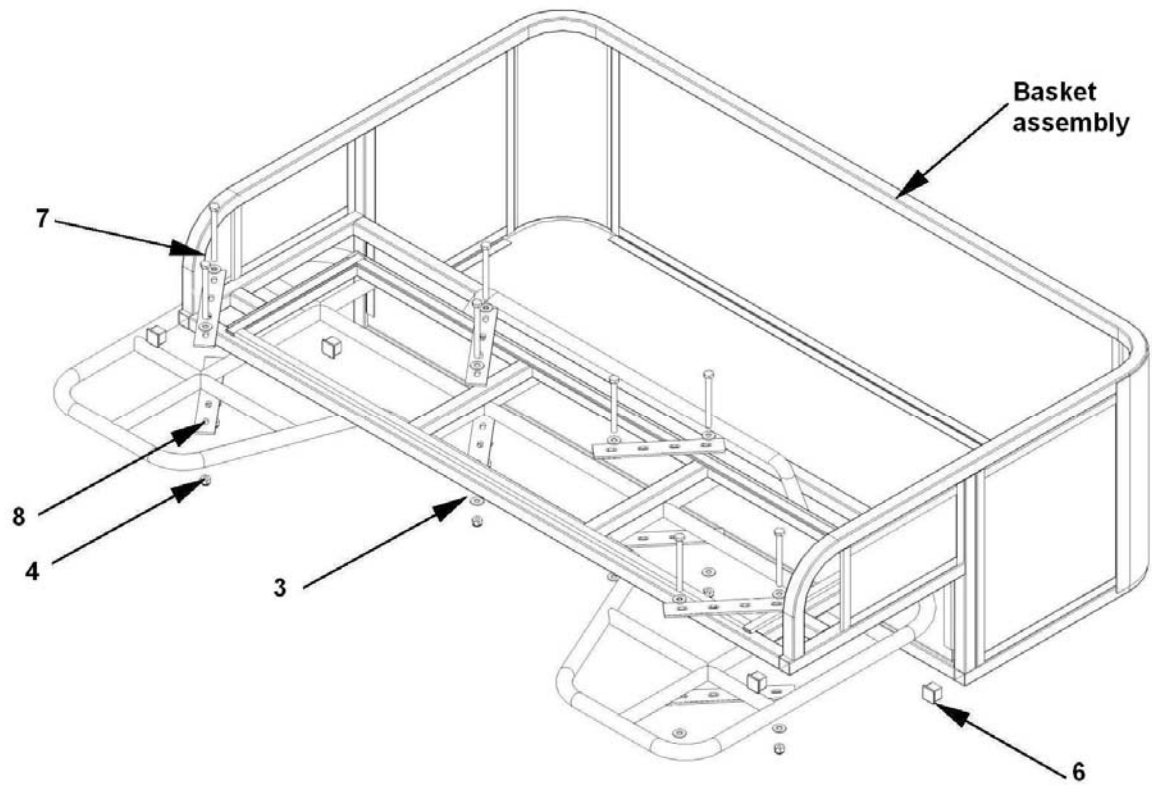

No.	Part #	Description	Qty
1	50028-10	Big Basket	1
2	50028-11	Hex Bolt M6X40	4
3	50028-12	Big Washer Ø6	24
4	50028-13	Hex Lock Nut M6	12
5	50028-14	Small Basket	1
6	50028-15	Plastic Cap	8
7	50028-16	Hex Bolt M6X65	8
8	50028-17	Mounting Brackets	8

Warranty

CHAMPION POWER EQUIPMENT ONE YEAR LIMITED WARRANTY

Effective September 1, 2006. Replaces all undated warranties and all warranties dated before September 1, 2006.

Warranty Qualifications

Champion Power Equipment (CPE) will register this warranty upon receipt of your Warranty Registration Card and a copy of your sales receipt from one of CPE's retail locations as proof of purchase.

Please submit your warranty registration and your proof of purchase within ten (10) days of the date of purchase.

Repair/Replacement Warranty

CPE warrants to the original purchaser that the mechanical and electrical components will be free of defects in material and workmanship for a period of one (1) year from the original date of purchase (90 days for commercial & industrial use). Transportation charges on product submitted for repair or replacement under this warranty are the sole responsibility of the purchaser. This warranty only applies to the original purchaser and is not transferable.

Do not return the unit to the place of purchase

Contact CPE's Technical Service and CPE will troubleshoot any issue via phone or e-mail. If the problem is not corrected by this method, CPE will, at its option, authorize evaluation, repair or replacement of the defective part or component at a CPE Service Center. CPE will provide you with a case number for warranty service. Please keep it for future reference. Repairs or replacements without prior authorization, or at an unauthorized repair facility, will not be covered by this warranty.

Warranty Exclusions

This warranty does not cover the following repairs and equipment:

Normal Wear

This warranty does not cover repair when normal use has exhausted the life of a part or the equipment as a whole.

Installation, Use and Maintenance

This warranty will not apply to parts and/or labor if this basket is deemed to have been misused, neglected, involved in an accident, abused, loaded beyond its limits, modified, or installed improperly. Normal maintenance is not covered by this warranty.

Other Exclusions

This warranty excludes:

Cosmetic defects such as paint, decals, etc.

Accessory parts such as storage covers.

Failures due to acts of God and other force majeure events beyond the manufacturer's control.

Problems caused by parts that are not original Champion Power Equipment parts.

Limits of Implied Warranty and Consequential Damage

Champion Power Equipment disclaims any obligation to cover any loss of time, use of this product, freight, or any incidental or consequential claim by anyone from using this winch. THIS WARRANTY IS IN LIEU OF ALL OTHER WARRANTIES, EXPRESS OR IMPLIED, INCLUDING WARRANTIES OF MERCHANTABILITY OR FITNESS FOR A PARTICULAR PURPOSE

A unit provided as an exchange will be subject to the warranty of the original unit. The length of the warranty governing the exchanged unit will remain calculated by reference to the purchase date of the original unit.

This warranty gives you certain legal rights which may change from state to state. Your state may also have other rights you may be entitled to that are not listed within this warranty.

Contact Information

Address

Champion Power Equipment, Inc.
Customer Service

10006 Santa Fe Springs Rd.
Santa Fe Springs, CA 90670

Customer Service

Mon – Fri 8:30 AM – 5:00 PM (PST/PDT)

Toll Free: 1-877-338-0999

Fax no.: 1-562-236-9429

Technical Service

Mon – Fri 8:30 AM – 5:00 PM (PST/PDT)

Toll Free: 1-877-338-0999

tech@championpowerequipment.com