

CHAMPION

GLOBAL POWER EQUIPMENT™

OWNER'S MANUAL & OPERATING INSTRUCTIONS



4000 Starting Watts / 3000 Rated Watts

PORTABLE GENERATOR



MODEL NUMBER

46555

SAVE THESE INSTRUCTIONS
Important Safety Instructions
are included in this manual.

MADE IN CHINA
REV 46555-20110708

10006 Santa Fe Springs Road
Santa Fe Springs CA 90670
USA / 1 (877) 338-0999
www.championpowerequipment.com

Have questions or need assistance?

Do not return this product to the store!

WE ARE HERE TO HELP!

Visit our website:

www.championpowerequipment.com

for more info:

- Product Info & Updates
- Tech Bulletins
- Frequently Asked Questions
- Product Registration

– or –

Call our Customer Care Team Toll-Free at:

1-877-338-0999

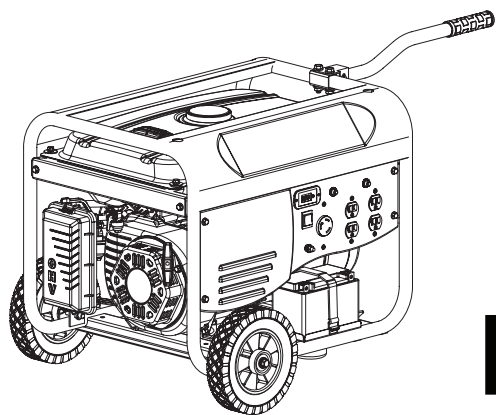

4000 Starting Watts / 3000 Rated Watts PORTABLE GENERATOR

TABLE OF CONTENTS

Introduction	1	Air Filter	14
Introduction	1	Cleaning	14
Portable Power Generator	1	Adjustments	14
Accessories	1	Maintenance Schedule	14
This Booklet	1	Generator Maintenance	14
Manual Conventions	2	Storage	15
Safety Rules	3	Generator Storage	15
Controls and Features	5	Disconnect the Battery	15
Generator	5	Charge the Battery	15
Power Panel	6	Specifications	16
Parts Included	7	Engine Specifications	16
Wheel Kit	7	Generator Specifications	16
Spark Arrester Kit	7	Fuel	16
Other	7	Oil	16
Assembly	8	Spark Plugs	16
Remove the Generator from the Shipping Carton	8	Valve Clearance	16
Install the Wheel Kit	8	Parts Diagram	17
Install the Support Leg	8	Parts List	18
Connect the Battery	8	Engine Parts Diagram	19
Add Engine Oil	8	Engine Parts List	20
Add Fuel	9	Wiring Diagram	21
Grounding	9	Troubleshooting	22
Operation	10	Warranty	23
Generator Location	10	Warranty Qualifications	23
Grounding	10	Repair/Replacement Warranty	23
Surge Protection	10	Do Not Return The Unit To	
Starting the Engine	10	The Place Of Purchase	23
Connecting Electrical Loads	11	Warranty Exclusions	23
Stopping the Engine	11	Normal Wear	23
Do Not Overload Generator	12	Installation, Use and Maintenance	23
Capacity	12	Other Exclusions	23
Power Management	12	Limits of Implied Warranty	
Wattage Reference Chart	12	and Consequential Damage	23
Maintenance and Storage	13	Contact Information	23
Engine Maintenance	13	Address	23
Oil	13	Customer Service	23
Spark Plugs	13	Technical Service	23

INTRODUCTION

Introduction

Congratulations on your purchase of a Champion Power Equipment generator. CPE designs and builds generators to strict specifications. With proper use and maintenance, this generator will bring years of satisfying service.

Portable Power Generator

This unit is a gasoline engine driven, alternating current (AC) generator. It is designed to supply electrical power for lighting, appliances, tools and similar equipment.

Accessories

Champion Power Equipment manufactures and sells accessories designed to help you get the most from your purchase. To find out more about our covers, power cables and storm kits, please visit our web site at:
→ www.championpowerequipment.com

This Booklet

Every effort has been made to ensure the accuracy and completeness of the information in this manual. We reserve the right to change, alter and/or improve the product and this document at any time without prior notice.

Record the model and serial numbers as well as date and place of purchase for future reference. Have this information available when ordering parts and when making technical or warranty inquiries.

Champion Power Equipment Support	
1 (877) 338-0999	
Model Number	
46555	
Serial Number	
Date of Purchase	
Purchase Location	
For Oil Type see 'Add Engine Oil' section. For Fuel Type see 'Add Fuel' section.	

This manual uses the following symbols to help differentiate between different kinds of information. The safety symbol is used with a key word to alert you to potential hazards in operating and owning power equipment.

Follow all safety messages to avoid or reduce the risk of serious injury or death.

 **DANGER**

DANGER indicates an imminently hazardous situation which, if not avoided, **will** result in death or serious injury.

 **WARNING**

WARNING indicates a potentially hazardous situation which, if not avoided, **could** result in death or serious injury.

 **CAUTION**

CAUTION indicates a potentially hazardous situation which, if not avoided, **may** result in minor or moderate injury.

CAUTION

CAUTION used without the safety alert symbol indicates a potentially hazardous situation which, if not avoided, **may** result in property damage.

 **NOTE**

If you have questions regarding your generator, we can help. Please call our help line at **1 (877) 338-0999**

SAFETY RULES

WARNING

Read this manual thoroughly before operating your generator. Failure to follow instructions could result in serious injury or death.

WARNING

The engine exhaust from this product contains chemicals known to the state of California to cause cancer, birth defects, or other reproductive harm.

DANGER

Generator exhaust contains carbon monoxide, a colorless, odorless, poison gas. Breathing carbon monoxide will cause nausea, dizziness, fainting or death. If you start to feel dizzy or weak, get to fresh air immediately.

Operate generator outdoors only in a well ventilated area.

DO NOT operate the generator inside any building, including garages, basements, crawlspaces and sheds, enclosure or compartment, including the generator compartment of a recreational vehicle. DO NOT allow exhaust fumes to enter a confined area through windows, doors, vents or other openings.

DANGER CARBON MONOXIDE: using a generator indoors **CAN KILL YOU IN MINUTES.**

DANGER

Rotating parts can entangle hands, feet, hair, clothing and/or accessories.
Traumatic amputation or severe laceration can result.

Keep hands and feet away from rotating parts.
Tie up long hair and remove jewelry.
Operate equipment with guards in place.
DO NOT wear loose-fitting clothing, dangling drawstrings or items that could become caught.

DANGER

Generator produces powerful voltage.

DO NOT touch bare wires or receptacles.
DO NOT use electrical cords that are worn, damaged or frayed.
DO NOT operate generator in wet weather.
DO NOT allow children or unqualified persons to operate or service the generator
Use a ground fault circuit interrupter (GFCI) in damp areas and areas containing conductive material such as metal decking.
Use approved transfer equipment to isolate generator from your electric utility and Notify your utility company before connecting your generator to your power system.

WARNING

Sparks can result in fire or electrical shock.

When servicing the generator:

Disconnect the spark plug wire and place it where it cannot contact the plug.
DO NOT check for spark with the plug removed.
Use only approved spark plug testers.

WARNING

Running engines produce heat. Severe burns can occur on contact.
Combustible material can catch fire on contact.

DO NOT touch hot surfaces.
Avoid contact with hot exhaust gases.
Allow equipment to cool before touching.
Maintain at least three feet of clearance on all sides to ensure adequate cooling.
Maintain at least five feet of clearance from combustible materials.

⚠ DANGER

Fuel and fuel vapors are highly flammable and extremely explosive.
Fire or explosion can cause severe burns or death.
Unintentional startup can result in entanglement, traumatic amputation or laceration.

When adding or removing fuel:

Turn the generator off and let it cool for at least two minutes before removing the fuel cap. Loosen the cap slowly to relieve pressure in the tank.
Only fill or drain fuel outdoors in a well-ventilated area. DO NOT overfill the fuel tank.
Always keep fuel away from sparks, open flames, pilot lights, heat and other sources of ignition.
DO NOT light or smoke cigarettes.

When starting the generator:

DO NOT attempt to start a damaged generator.
Make certain that the gas cap, air filter, spark plug, fuel lines and exhaust system are properly in place.
Allow spilled fuel to evaporate fully before attempting to start the engine.
Make certain that the generator is resting firmly on level ground.

When operating the generator:

DO NOT move or tip the generator during operation.
DO NOT tip the generator or allow fuel or oil to spill.

When transporting or servicing the generator:

Make certain that the fuel shutoff valve is in the off position and the fuel tank is empty.
Disconnect the spark plug wire.
When storing the generator:
Store away from sparks, open flames, pilot lights, heat and other sources of ignition.

⚠ WARNING

Operation of this equipment may create sparks that can start fires around dry vegetation.

A spark arrestor may be required. The operator should contact local fire agencies for laws or regulations relating to fire prevention requirements.

⚠ WARNING

Rapid retraction of the starter cord will pull hand and arm towards the engine faster than you can let go.
Unintentional startup can result in entanglement, traumatic amputation or laceration.
Broken bones, fractures, bruises or sprains could result.

When starting engine, pull the starter cord slowly until resistance is felt and then pull rapidly to avoid kickback.
DO NOT start or stop the engine with electrical devices plugged in.

⚠ CAUTION

Exceeding the generator's running capacity can damage the generator and/or electrical devices connected to it.

DO NOT overload the generator.
Start the generator and allow the engine to stabilize before connecting electrical loads.
Connect electrical equipment in the off position, and then turn them on for operation.
Turn electrical equipment off and disconnect before stopping the generator.
DO NOT tamper with the governed speed.
DO NOT modify the generator in any way.

⚠ CAUTION

Improper treatment or use of the generator can damage it, shorten its life and void your warranty.

Use the generator only for intended uses.
Operate only on level surfaces.
DO NOT expose generator to excessive moisture, dust, or dirt.
DO NOT allow any material to block the cooling slots.
If connected devices overheat, turn them off and disconnect them from the generator.
DO NOT use the generator if:

- Electrical output is lost
- Equipment sparks, smokes or emits flames
- Equipment vibrates excessively

CONTROLS AND FEATURES

Read this owner's manual before operating your generator. Familiarize yourself with the location and function of the controls and features. Save this manual for future reference.

Generator

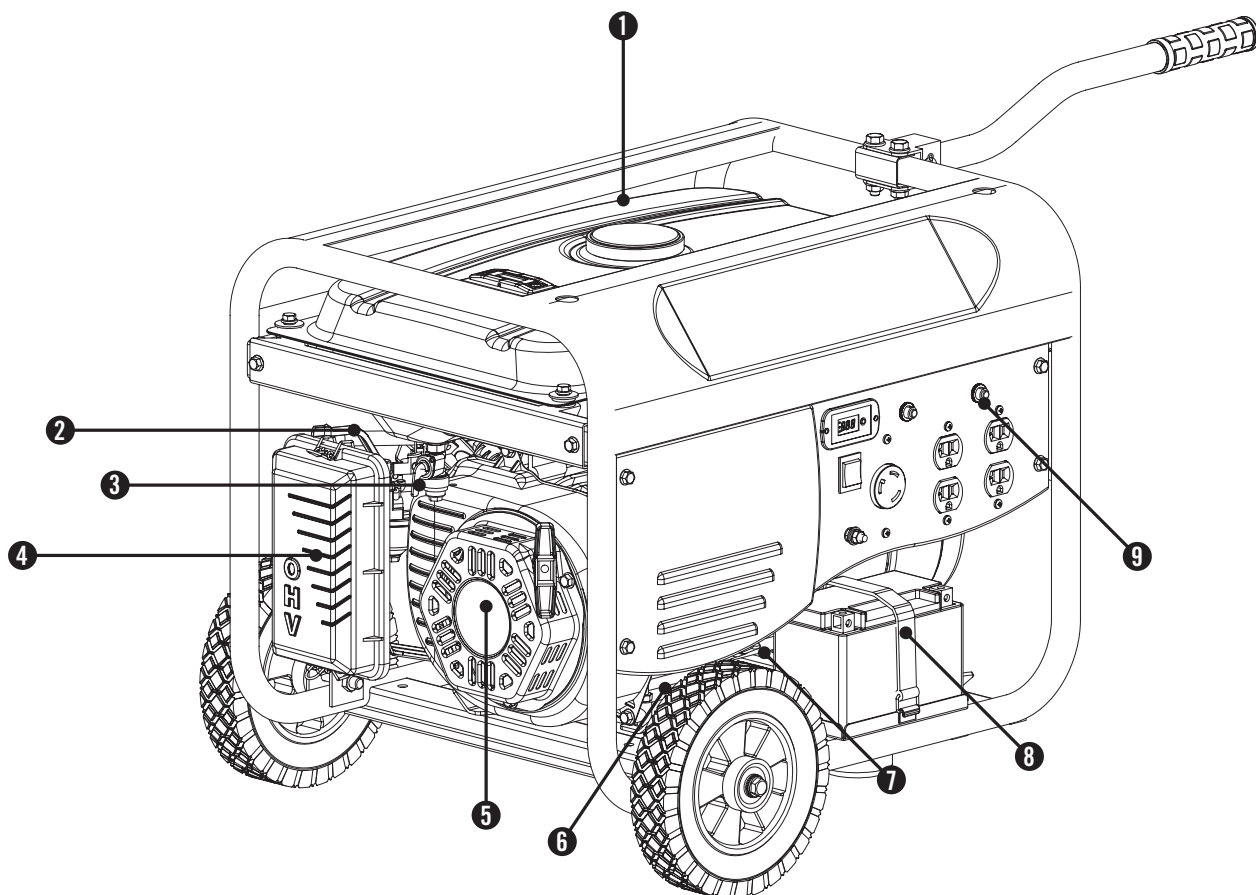

- | | |
|---|--|
| <p>(1) Fuel Tank – 4.0 gallon (15L) capacity fuel tank.</p> <p>(2) Choke Lever – Used to start the engine.</p> <p>(3) Fuel Valve – Turn this valve to the “ON” position to supply fuel to the engine.</p> <p>(4) Air Cleaner – Protects the engine by filtering dust and debris from the intake air.</p> <p>(5) Recoil Starter – Used to start the engine.</p> | <p>(6) Low Oil Sensor – Senses the level of oil in the crankcase and shuts the engine down if the level falls too low.</p> <p>(7) Oil Filler Cap – Check and fill engine oil level.</p> <p>(8) Battery – Used to start the engine.</p> <p>(9) Power Panel – See “Power Panel”.</p> |
|---|--|

Power Panel

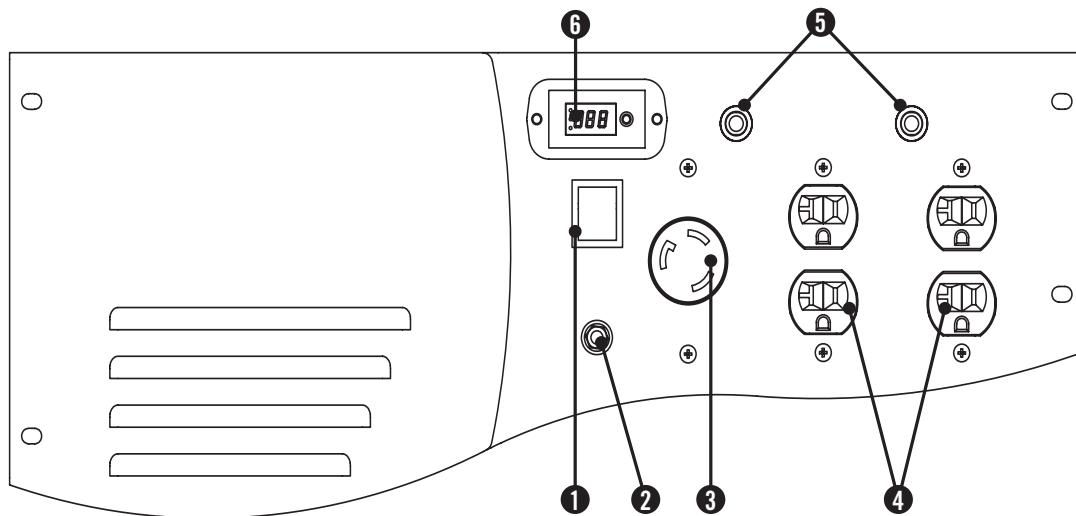

- (1) Ignition Switch** – Press the switch to the “START” position to start the generator, or to the “ON” position to start the generator manually. Flip to the “OFF” position to turn off the generator.
- (2) Ground Terminal** – Consult an electrician for local grounding regulations.
- (3) 120V / 30A Twist-Lock** – protected by a 25 Amp circuit breaker. This receptacle powers 120 Volt AC, 60 Hz, single phase loads requiring up to 25 Amps or 3000 watts of power.
- (4) 120V / 20A Duplex (2)** – Each duplex is protected by a 20 Amp circuit breaker. Use each duplex to operate 120 Volt AC, single phase, 60 Hz loads requiring up to 20 Amps Or 2400 Watts of power.
- (5) Circuit Breakers** – Protects the generator against electrical overload.
- (6) Intelligauge** – Tri-mode digital display for running hours, voltage and hertz.

CONTROLS AND FEATURES

Parts Included

Your 46555 Gasoline Powered Generator ships with the following parts:

Wheel Kit

- 8" Wheel 2
- Bushing 2
- Flange Bolt (M10x105 for Wheel) 2
- Flat Washer 10 2
- Nut (M10) 2
- Support Leg w/Vibration Mounts 1
- Flange Bolt (M8x16 for Support Leg) 2
- Handle 1
- Flange Bolt (M8x45 for Handle) 2
- Nut (M8) 4

Other

- Oil Funnel 1
- Oil 0.63 qt. (0.6 L)
- Spark Plug Socket 1
- Cap Screw (M6x10 for Battery Terminals) 2
- Nut (M6) 2
- RV Adapter Plug 1

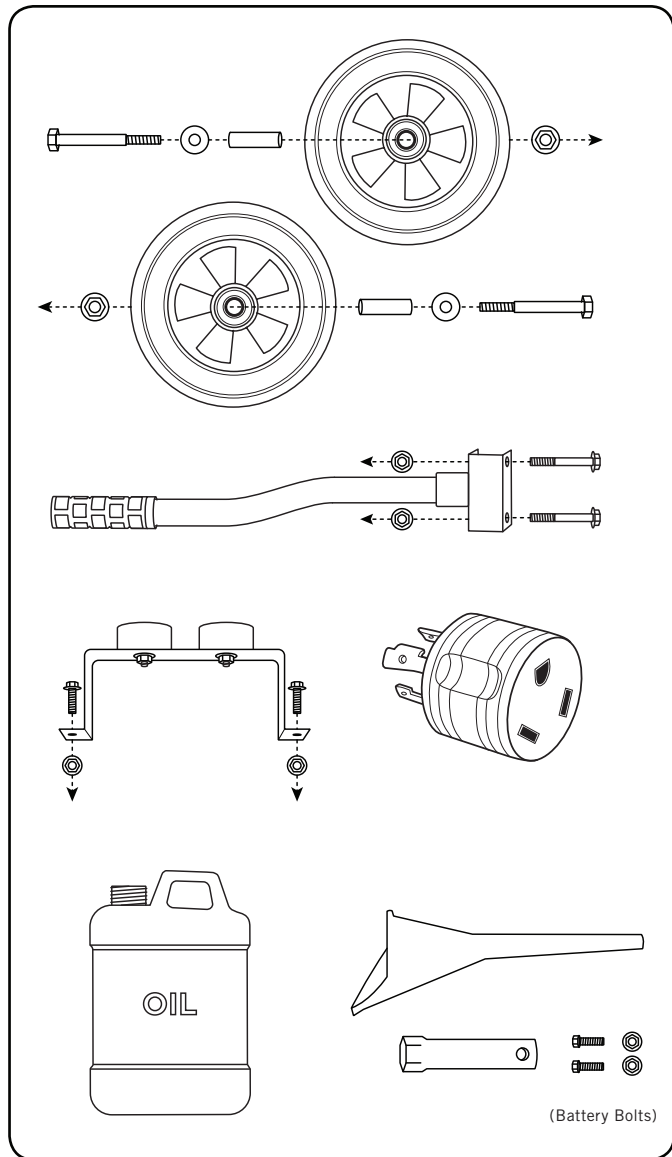

Your generator requires some assembly. This unit ships from our factory without oil. It must be properly serviced with fuel and oil before operation.

If you have any questions regarding the assembly of your generator, call our help line at 1 (877) 338-0999. Please have your serial number and model number available.

Remove the Generator from the Shipping Carton

1. Set the shipping carton on a solid, flat surface.
2. Remove everything from the carton except the generator.
3. Carefully cut each corner of the box from top to bottom. Fold each side flat on the ground to provide a surface area to install the wheel kit and support leg.

Install the Wheel Kit

! CAUTION

The wheel kit is not intended for over-the-road use.

You will need the following tools to install the wheels:

- 17 mm wrench OR adjustable wrench (not included)
- Socket wrench with a 16 mm socket (not included)
- Pliers (not included)

1. Before adding fuel and oil, tip the generator on it's side.
2. Slide the wheel bolt (M10x105) through the washer, sleeve and wheel.
3. Slide the bolt through the mount point on the frame.
4. Fasten securely with the M10 nut.
5. Repeat steps 2-4 to attach the second wheel.

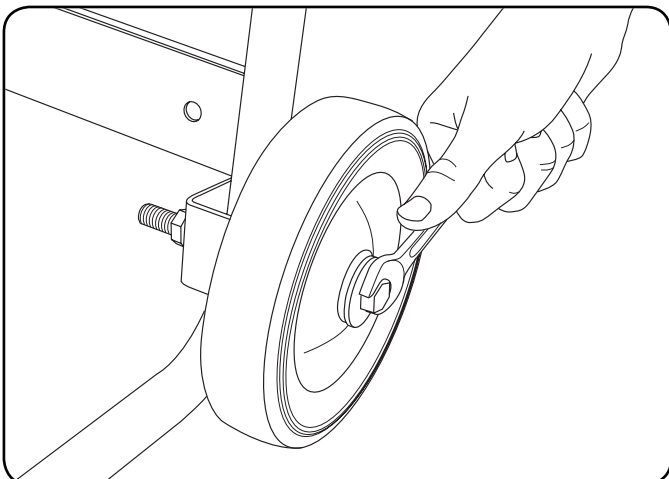

Install the Support Leg

1. Attach the support leg to the generator frame with cap screws (M8x16) and lock nuts (M8).
2. Tip the generator slowly so that it rests on the wheels and support leg.

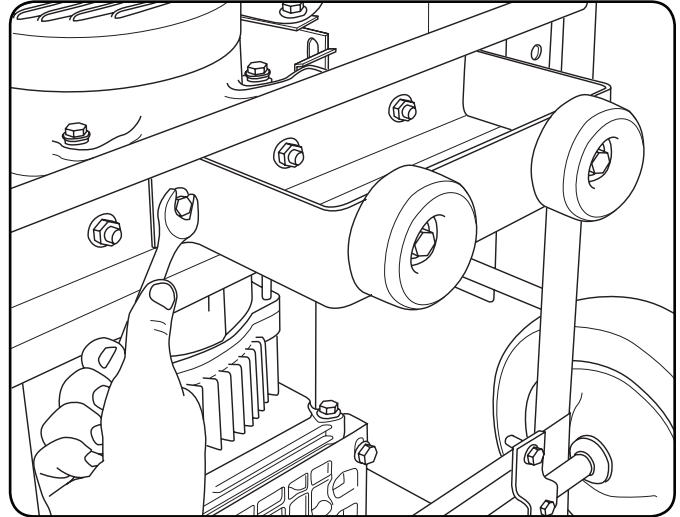

Connect the Battery

1. Remove the protective cover from the red (+) lead on the battery.
2. Attach the red (+) lead to the red (+) terminal on the battery with the cap screw (M6x10) and secure with the lock washer (M6)
3. Repeat steps 1-2 for the black (-) battery lead.

Add Engine Oil

! CAUTION

DO NOT attempt to crank or start the engine before it has been properly filled with the recommended type and amount of oil. Damage to the generator as a result of failure to follow these instructions will void your warranty.

NOTE

The recommended oil type is 10W-30 4-cycle automotive oil.

ASSEMBLY

Add Engine Oil Cont'd.

1. Place the generator on a flat, level surface.

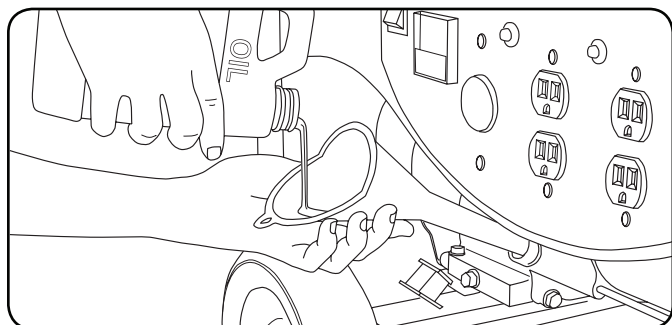

2. Remove oil fill cap/dipstick to add oil.
3. Add 0.63 qt (0.6 L) of oil and replace oil fill cap/dipstick.

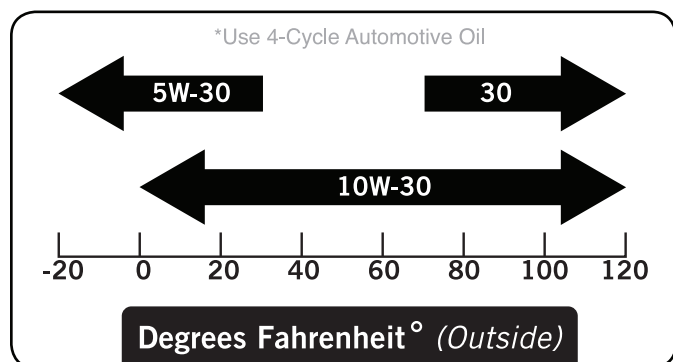

4. Check engine oil level daily and add as needed.

CAUTION

The engine is equipped with a low-oil-shutoff and will stop when the oil level in the crankcase falls below the threshold level.

NOTE

Check oil often during the break-in period. Refer to the Maintenance section for recommended service intervals.

NOTE

The generator rotor has a sealed, pre-lubricated ball bearing that requires no additional lubrication for the life of the bearing.

Add Fuel

1. Use clean, fresh, regular unleaded fuel with a minimum octane rating of 85 and an ethanol content of less than 10% by volume.
2. DO NOT mix oil with fuel.
3. Clean the area around the fuel cap.
4. Remove the fuel cap.
5. Slowly add fuel to the tank. DO NOT overfill. Fill to the top of the fuel filter inside the fuel tank.

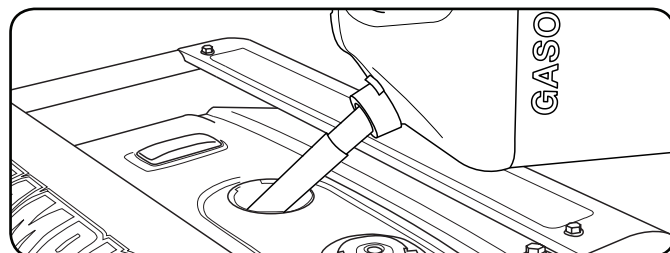

6. Screw on the fuel cap and wipe away any spilled fuel.

! CAUTION

Use regular unleaded gasoline with a minimum octane rating of 85.

Do not mix oil and gasoline.
 Fill tank to approximately ¼" below the top of the tank to allow for fuel expansion.
 DO NOT fill fuel tank indoors.
 DO NOT fill fuel tank when the engine is running or hot.
 DO NOT overfill the fuel tank.
 DO NOT light cigarettes or smoke when filling the fuel tank.

Grounding

Your generator must be properly connected to an appropriate ground to help prevent electric shock.

! WARNING

Failure to properly ground the generator can result in electric shock.

A ground terminal connected to the frame of the generator has been provided on the power panel. For remote grounding, connect a length of heavy gauge (12 AWG minimum) copper wire between the generator ground terminal and a copper rod driven into the ground. We strongly recommend that you consult with a qualified electrician to ensure compliance with local electrical codes.

Generator Location

Please consult your local authority. In some areas, generators must be registered with the local utility. Generators used at construction sites may be subject to additional rules and regulations.

This generator must have at least five feet of clearance from combustible material. Leave at least three feet of clearance on all sides of the generator to allow for adequate cooling, maintenance and servicing.

Place the generator in a well-ventilated area. DO NOT place the generator near vents or intakes where exhaust fumes could be drawn into occupied or confined spaces. Carefully consider wind and air currents when positioning generator.

Grounding

The generator system ground connects the frame to the ground terminals on the power panel.

- The generator (stator winding) is isolated from the frame and from the AC receptacle ground pin.
- Electrical devices that require a grounded receptacle pin connection will not function if the receptacle ground pin is not functional.

Surge Protection

CAUTION

Voltage fluctuation may impair the proper functioning of sensitive electronic equipment.

Electronic devices, including computers and many programmable appliances use components that are designed to operate within a narrow voltage range and may be affected by momentary voltage fluctuations. While there is no way to prevent voltage fluctuations, you can take steps to protect sensitive electronic equipment.

1. *Install UL1449, CSA-listed, plug-in surge suppressors on the outlets feeding your sensitive equipment.* Surge suppressors come in single- or multi-outlet styles. They're designed to protect against virtually all short-duration voltage fluctuations.

Starting the Engine

1. Make certain the generator is on a flat, level surface.
2. Disconnect all electrical loads from the generator. Never start or stop the generator with electrical devices plugged in or turned on.
3. Turn the Fuel Valve to the "ON" position.
4. Flip the ignition switch to the "ON" position.
5. Move the choke lever to the "CHOKE" position.
6. ELECTRIC START: Press and hold the ignition switch to the "START" position. Release as the engine begins to roll over. If the engine fails to start within five seconds, release the switch and wait at least ten seconds before attempting to start the engine again.
7. RECOIL START: Pull the starter cord slowly until resistance is felt and then pull rapidly
8. Do not over-choke. As soon as engine starts, move the choke lever to the "RUN" position.

NOTE

If the engine starts but does not run make certain that the generator is on a flat, level surface. The engine is equipped with a low oil sensor that will prevent the engine from running when the oil level falls below a critical threshold.

OPERATION

Connecting Electrical Loads

1. Let the engine stabilize and warm up for a few minutes after starting
 - DO NOT connect 3-phase loads to the generator.
 - DO NOT connect 50 Hz loads to the generator.
 - DO NOT overload the generator.

NOTE

Connecting a generator to your electric utility company's power lines or to another power source may be against the law. In addition this action, if done incorrectly, could damage your generator and appliances and could cause serious injury or even death to you or a utility worker who may be working on nearby power lines. If you plan to run a portable electric generator during an outage, please notify your electric utility company immediately and remember to plug your appliances directly into the generator. Do not plug the generator into any electric outlet in your home. Doing so could create a connection to the utility company power lines. You are responsible for ensuring that your generator's electricity does not feed back into the electric utility power lines.

If the generator will be connected to a building electrical system, consult your local utility company or a qualified electrician. Connections must isolate generator power from utility power and must comply with all applicable laws and codes.

Stopping the Engine

1. Turn off and unplug all electrical loads. Never start or stop the generator with electrical devices plugged in or turned on.
2. Let the generator run at no-load for several minutes to stabilize internal temperatures of the engine and generator.
3. Press the ignition switch to the "OFF" position.
4. Turn the Fuel Valve to the "OFF" position.

Important: If the generator will be moved or stored turn the Fuel Valve to the "OFF" position and ensure the Ignition Switch on the Power Panel is in the "OFF" position.

Do Not Overload Generator

Capacity

Follow these simple steps to calculate the running and starting watts necessary for your purposes.

1. Select the electrical devices you plan on running at the same time.
2. Total the running watts of these items. This is the amount of power you need to keep your items running.
3. Identify the highest starting wattage of all devices identified in step 1. Add this number to the number calculated in step 2. Surge wattage is the extra burst of power needed to start some electric driven equipment. Following the steps listed under “Power Management” will guarantee that only one device will be starting at a time.

Power Management

Use the following formula to convert voltage and amperage to watts:

$$\text{Volts} \times \text{Amps} = \text{Watts}$$

To prolong the life of your generator and attached devices, follow these steps to add electrical load:

1. Start the generator with no electrical load attached
2. Allow the engine to run for several minutes to stabilize.
3. Plug in and turn on the first item. It is best to attach the item with the largest load first.
4. Allow the engine to stabilize.
5. Plug in and turn on the next item.
6. Allow the engine to stabilize.
7. Repeat steps 5-6 for each additional item.

 **NOTE**

Never exceed the specified capacity when adding loads to the generator.

Wattage Reference Chart

Use the chart to determine approximate wattage requirements for your equipment.

CAUTION

Exceeding specified load capacity can result in damage to the generator.

To determine total wattage necessary to power a device, **ADD Running Watts to Starting Watts.** (A+B)

Item	Running Watts (A)	Starting Watts (B)
Essentials		
Light Bulb 100W	100	
Refrigerator/Freezer	1200	2400
Freezer	500	500
Sump Pump	600	1800
Well Pump 1 HP	2000	4000
Water Heater	4000	
Security System	180	
AM/FM Radio	300	
Garage Door Opener 1/2 HP	500	600
Battery Charger 12V DC	110	
Heating/Cooling		
Air Conditioner 12000 BTU	1700	2500
Fan	300	600
Furnace Fan 1/3 HP	1200	2000
Home Appliances		
Microwave 1000W	1000	
Electric Range - One Element	1500	
Electric Skillet	1250	
Coffee Maker	1500	
Clothes Washer	1200	
Entertainment		
CD/DVD Player / VCR	100	
Stereo Receiver	450	
Television 27"	500	
PC with 15" Monitor	800	
Job Site		
Belt Sander 3"	1000	1500
Bench Grinder 6"	700	1500
Circular Saw	1500	1500
Compressor 1 1/2 HP	2500	2500
Edge Trimmer	500	500
Hand Drill 1/2"	1000	1000
Lawn Mower	1200	1800
Paint Sprayer	600	1200
Table Saw	2000	2000

MAINTENANCE AND STORAGE

The owner/operator is responsible for all periodic maintenance.

WARNING

Never operate a damaged or defective generator.

WARNING

Tampering with the factory set governor will void your warranty.

WARNING

Improper maintenance will void your warranty.

NOTE

Maintenance, replacement, or repair of emission control devices and systems may be performed by any non-road engine repair establishment or individual.

Complete all scheduled maintenance in a timely manner. Correct any issue before operating the generator.

NOTE

For service or parts assistance, contact our help line at **1 (877) 338-0999**

Engine Maintenance

To prevent accidental starting, remove and ground spark plug wire before performing any service.

Oil

Change oil when the engine is warm. Refer to the oil specification to select the proper grade of oil for your operating environment.

1. Remove the oil drain plug with a 12 mm socket and extension.
2. Allow the oil to drain completely.
3. Replace the drain plug.
4. Remove oil fill cap/dipstick to add oil.
5. Add 0.63 qt (0.6 L) of oil and replace oil fill cap/dipstick.

Oil Cont'd.

NOTE

Once oil has been added, a visual check should show oil about 1-2 threads from running out of the fill hole. If using the dipstick to check oil level, **DO NOT** screw in the dipstick while checking.

6. Dispose of used oil at an approved waste management facility.

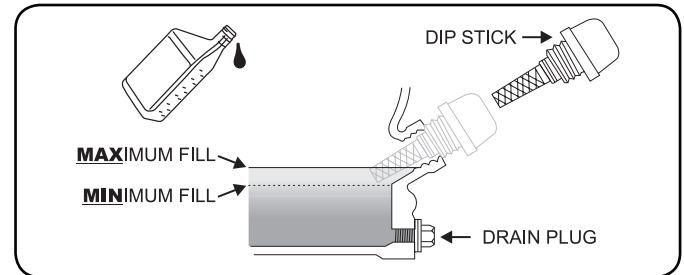

Spark Plugs

1. Remove the spark plug cable from the spark plug.
2. Use the spark plug tool that shipped with your generator to remove the plug.
3. Inspect the electrode on the plug. It must be clean and not worn to produce the spark required for ignition.
4. Make certain the spark plug gap is 0.7 - 0.8mm or (0.028 - 0.031 in.).

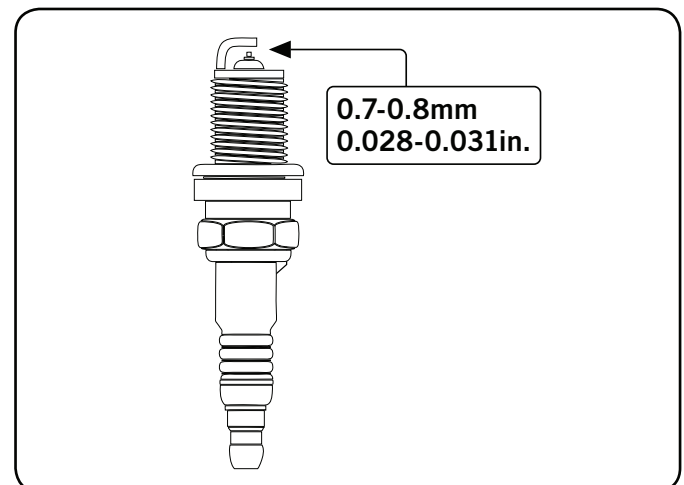

5. Refer to the spark plug recommendation in Specifications section when replacing the plug.
6. Carefully thread the plug into the engine.
7. Use the spark plug tool to firmly install the plug.
8. Attach the spark plug wire to the plug.

Air Filter

1. Remove the snap-on cover holding the air filter to the assembly.
2. Remove the foam element.
3. Wash in liquid detergent and water. Squeeze thoroughly dry in a clean cloth.
4. Saturate in clean engine oil.
5. Squeeze in a clean, absorbent cloth to remove all excess oil.
6. Place the filter in the assembly.
7. Reattach the air filter cover and snap in place.

Cleaning

! CAUTION

DO NOT spray engine with water.

Water can contaminate the fuel system.

Use a damp cloth to clean exterior surfaces of the engine.

Use a soft bristle brush to remove dirt and oil.

Use an air compressor (25 PSI) to clear dirt and debris from the engine.

Adjustments

The air-fuel mixture is not adjustable. Tampering with the governor can damage your generator and your electrical devices and will void your warranty. CPE recommends that you contact our service line at **1 (877) 338-0999** for all other service and/or adjustment needs.

Maintenance Schedule

Follow the service intervals indicated in the following maintenance schedule.

Service your generator more frequently when operating in adverse conditions.

Contact our help line at **1 (877) 338-0999** to locate the nearest Champion Power Equipment certified service dealer for your generator or engine maintenance needs.

Every 8 hours or daily	
	Check oil level
	Clean around air intake and muffler
First 5 Hours	
	Change oil
Every 50 hours or every season	
	Clean air filter
	Change oil if operating under heavy load or in hot environments
Every 100 hours or every season	
	Change oil
	Clean/Adjust spark plug
	Check/Adjust valve clearance *
	Clean spark arrester
	Clean fuel tank and filter *
Every 3 years	
	Replace fuel line

*To be performed by knowledgeable, experienced owners or Champion Power Equipment certified dealers.

Generator Maintenance

Make certain that the generator is kept clean and stored properly. Only operate the unit on a flat, level surface in a clean, dry operating environment. DO NOT expose the unit to extreme conditions, excessive dust, dirt, moisture or corrosive vapors.

! CAUTION

DO NOT use a garden hose to clean the generator.

Water can enter the generator through the cooling slots and damage the generator windings.

Use a damp cloth to clean exterior surfaces of the generator.

Use a soft bristle brush to remove dirt and oil.

Use an air compressor (25 PSI) to clear dirt and debris from the generator.

Inspect all air vents and cooling slots to ensure that they are clean and unobstructed.

MAINTENANCE AND STORAGE

Storage

The generator should be started at least once every 14 days and allowed to run for at least 20 minutes. For longer term storage, please follow these guidelines.

Generator Storage

1. Allow the engine to cool completely before storage.
2. Clean the generator according to the instructions in the Maintenance section.
3. Turn off the fuel supply at the Fuel Valve.
4. Drain all fuel completely from the fuel line and carburetor to prevent gum from forming.
5. Add a fuel stabilizer into the fuel tank.
6. Change the oil.
7. Remove the spark plug and pour about ½ ounce of oil into the cylinder. Crank the engine slowly to distribute the oil and lubricate the cylinder.
8. Reattach the spark plug.
9. Store the unit in a clean, dry place out of direct sunlight.

DANGER

Generator exhaust contains odorless and colorless carbon monoxide gas.

To avoid accidental or unintended ignition of your electric start generator during periods of storage, the following precautions should be followed:

- When **storing the generator for short periods of time** make sure that the Ignition Switch and the Fuel Valve are switched to the **OFF** position.
- When **storing the generator for extended periods of time** make sure that the Ignition Switch and the Fuel Valve are switched to the **OFF** position and the battery leads have been **disconnected** from the battery.

Disconnect the Battery

1. Remove the protective cover from the black/negative battery lead.
2. Disconnect the black/negative lead from the black/negative terminal on the battery and store the cap screw (M6x10) and lock washer (M6).
3. Repeat steps 1-2 for the red/positive battery lead.
4. Store the battery in a cool, dry place.

Charge the Battery

Proper battery maintenance and storage should be followed. A 12V automatic battery charger with automatic trickle charging capability should be used to charge the battery. Maximum charging rate should not exceed 2 amps. Follow the instructions included with the battery charger. The battery should be fully charged at least once per month.

NOTE

A Float Charger will maintain the battery condition over long storage periods.

Engine Specifications

- Engine 196cc OHV CPE (Electric Start)

Generator Specifications

- Running Wattage 3000 Watts
- Starting Wattage 4000 Watts
- AC Voltage 120 V
- Phase Single
- Frequency 60 Hz
- Fuel Capacity 4.0 gallons (15 L)
- Gross Weight 133.4 lbs. (60.5 kg)
- Net Weight 125.6 lbs. (57.1 kg)
- Height 21.1 inches (53.5 cm)
- Width 23.7 inches (60.2 cm)
- Length 24.9 inches (63.3 cm)

Fuel

Fuel capacity is 4.0 gallons (15 L). Use regular unleaded gasoline with a minimum octane rating of 85 and an ethanol content of less than 10% by volume.

Oil

Use 10W-30 4-Cycle automotive oil.
 Oil capacity is 0.63 qt (0.6 L).
 Please reference the following chart for recommended oil types for use in the generator.

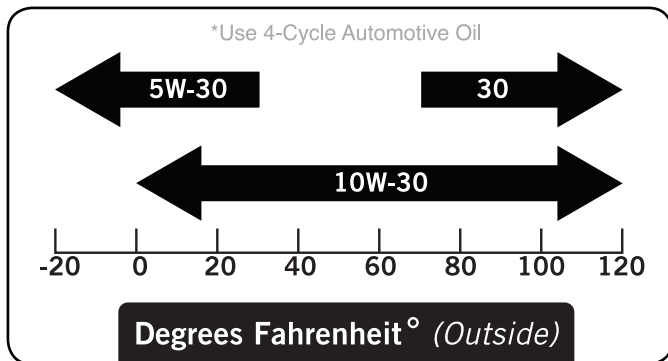

Spark Plugs

Recommended replacement spark plug:
 - **NGK BR6ES or equivalent**
 Make certain the spark plug gap is 0.7 – 0.8 mm or (0.028 – 0.031 in.).

Valve Clearance

- Intake: 0.13 – 0.15 mm (0.005 – 0.006 in.)
- Exhaust: 0.18 – 0.20 mm (0.007 – 0.008 in.)

SPECIFICATIONS

Parts Diagram

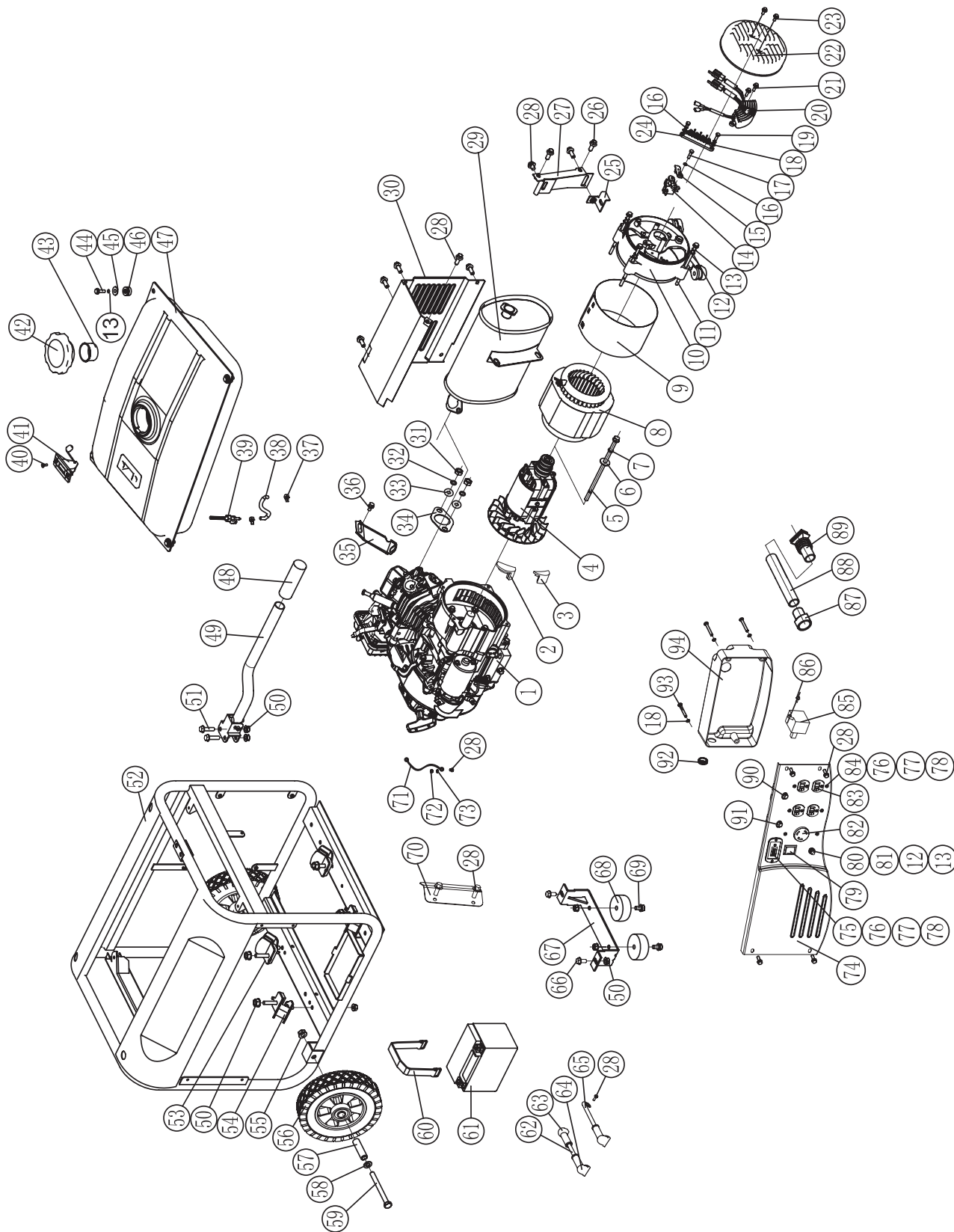

#	Part Number	Description	Qty
1	168FDE-2-G	Engine	1
2	ST02FD-02100011	Build Up B	1
3	ST02FD-02100012	Build Up A	1
4	ST02FD-02110000-2.5-CSA	Rotor Comp	1
5	ST02FD-02100005-2.5	Flange BoltM8x233	1
6	GB96 8	Washer 8	1
7	GB7244 8	Spring Washer 8	1
8	ST02FD-02120000-2.5-CSA	Stator Assy	1
9	ST02FD-02100002-2.5	Stator Cover	1
10	ST02FD-02100003	End Cover	1
11	ST02FD-02100001-2.5	Flange BoltM6x158	4
12	GB97.1 6	Washer 6	6
13	GB93 6	Spring Washer 6	10
14	ST02FD-02100009	Brush Assy	1
15	ST02FD-02100008	Plate Pinch	1
16	GB93 5	Spring Washer 5	5
17	GB5783 M5x20	Bolt M5x20	1
18	GB97.1 5	Washer 5	5
19	GB5783 M5x16	Bolt M5x16	2
20	ST02FD-02100007(CSA)	AVR	1
21	GB16674 M5X16	Flange Bolt M5x16	2
22	ST02FD-02100004(Y)	Generator End Cover	1
23	GB16674 M5X12	Flange Bolt M5x12	2
24	ST02FD-02100010	Terminal	1
25	ST02FD-1150200	Muffler Stay I	1
26	GB5789 M8X20	Flange Bolt M8x20	3
27	ST02FD-1150100	Muffler Stay II	1
28	GB5789 M6X12	Flange Bolt M6x12	14
29	ST168FD-1100000-G	Muffler	1
30	ST02FD-03030400(F)	Muffler Cover	1
31	GB6175 M8	NutM8	2
32	GB93 8	Spring washer 8	2
33	GB848 8	Washer 8	2
34	ST168F-1100200-G	Muffler Gasket	1
35	ST168FD-1090006	Air Cleaner stay	1
36	GB5789 M6x8	Flange Bolt M6x8	1
37	ST188FD-1070006A	Clip	2
38	168.070011.03	Fuel Line	1
39	ST02FD-04160000	Fuel Cock	1
40	GB819 M5X10	Screw M5x10	2
41	ST02FD-04140000	Fuel Meter Assy	1
42	ST02FD-04120000-A	Fuel Tank Cap	1
43	ST02FD-04130000	Fuel Filter	1
44	GB5789 M6x20	Flange Bolt M6x20	4
45	ST02FD-04100014	Washer 6.5	4
46	ST02FD-04100010	Tank Rubber	4
47	ST02FD-04110000(Y)	Fuel Tank	1
48	ST188FD-1741002-C	Handle sheath	1
49	ST182FD-1151110-B(F)	Handle	1

#	Part Number	Description	Qty
50	GB6177 M8	Nut M8	14
51	GB5789 M8x45	Flange Bolt M8x45	2
52	ST02FD-0211-2.5	frame	1
53	ST02FD-1151300C-1	Bottom RubberII	2
54	ST02FD-1151300D-1	Bottom RubberI	2
55	GB6182 M10	Nut M10	2
56	ST177FD-1152300(Y)	8in Wheel	2
57	ST02FD-03621001	Bush 10.5x58.5	2
58	GB96 10	Flat washer 10	2
59	GB5782 M10x105	Bolt M10x105	2
60	504.200904.00	Rubber belt	1
61	FM1290	9AH Battery	1
62	ST188FD-1750002-C3	Battery red wire(+)	1
63	ST05FD-03011112	jacket	1
64	ST168FD-1751002-A	jacket	2
65	ST188FD-1750002-C7	Battery black wire(-)	1
66	GB5789 M8x16	Flange Bolt M8x16	2
67	ST05FD-03020301-60(F)	Support leg	1
68	ST188FD-1743002-C	Vibration mount	2
69	GB5789 M8x25	Flange Bolt M8x25	2
70	ST02FD-03170001(F)	Control panel defend board	1
71	ST02FD-02100013(CSA)	Earth Line	1
72	GB6177 M6	Nut M6	1
73	GB862 6	Washer 6	1
74	2P12E(F)	Control panel	1
75	DP03-00000000	Trigita meter	1
76	GB823 M4x14	Screw M4x14	8
77	GB848 4	Washer 4	8
78	GB859 4	Spring washer 4	8
79	29.001.00	switch	1
80	GB5781 M6x22	Bolt M6x22	1
81	GB6175 M6	Nut M6	2
82	ST02FD-05502020(CSA)	Receptacle L5-30R	1
83	ST02FD-05502023(CSA)	5-20R Receptacle	2
84	GB6177 M4	Nut M4	6
85	OV02-00000000	Transition	1
86	GB823 M5x14	Screw M5x14	1
87	ST02FD-05212001	build up	1
88	ST02FD-05212006	Conduit	1
89	ST02FD-05212002	Build Up	1
90	ST02FD-05302001-L20(CSA)	AC.20A CIRCUIT BREAKERS	1
91	ST02FD-05302001-L25(CSA)	AC.25A CIRCUIT BREAKERS	1
92	ST188FD-1020001	grommet	1
93	GB823 M5x38	Screw M5x38	3
94	504.210002.00(CSA)	Control Box	1

SPECIFICATIONS

Engine Parts Diagram

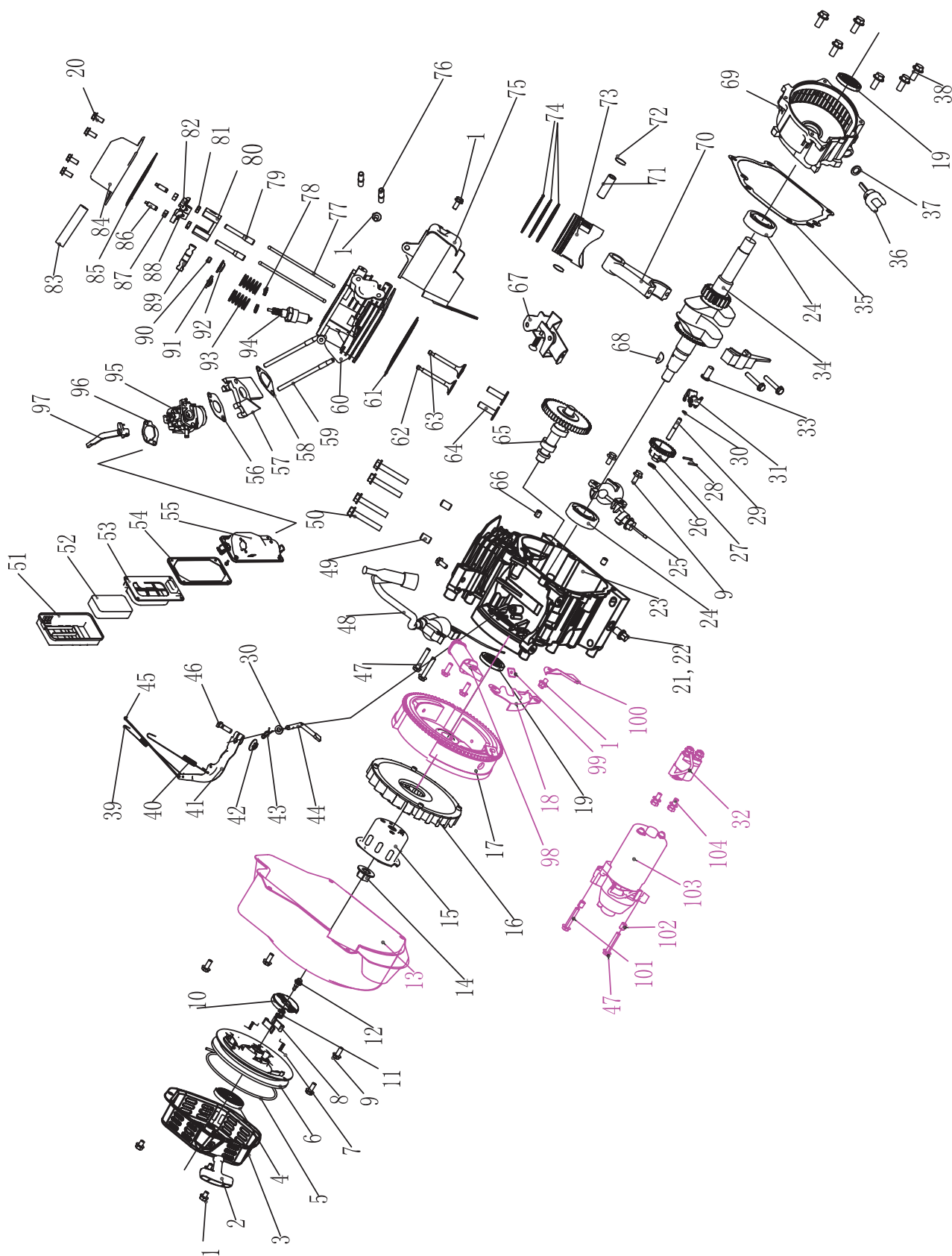

#	Part Number	Description	Qty
1	GB5789--86-FB6-8	Flange bolt 6*8	5
2	ST160F--1061200	Recoil starter knob	1
3	ST160F--1061100-Q	Recoil starter comp	1
4	ST160F--1061005	Recoil starter spring	1
5	ST160F--1061009	Recoil starter rope	1
6	ST160F--1061001-A	Recoil starter reel	1
7	ST188F--1060006	Return spring	2
8	ST188F--1060005	Starter ratchet Metal	2
9	GB5789--86-FB6-12	Flange bolt M6*12	8
10	ST188F--1060003	Ratchet guide	1
11	ST188F--1060004	Ratchet guide spring	1
12	ST188F-1060002	Setting screw	1
13	ST168F--1080100-G(Y)	Fan cover comp	1
14	ST160F--1050010	Nut M14	1
15	ST160F--1060001	Start hub	1
16	ST168F--1080001	Cooling fan	1
17	ST168F--1120100-A	Fly wheel	1
18	ST168F--1080200-A	Side place (II)	1
19	ST168F--1030100	Oil seal	2
20	GB5789--86-FB6-15	Flange bolt M6*15	4
21	ST160F--1030003	Drain plug bolt	2
22	ST160F--1030004	Drain bolt washer	2
23	ST168F-2-1030012-G-E	Crankcase for USA	1
24	GB/T--276--94	Radial ball bearing 6205	2
25	ST160F-1127000-A	Oil level switch assy	1
26	ST160F--1110108	Governor washer (II)	1
27	ST160F--1110101	Governor weight holder	1
28	ST160F--1110102	Governor weight pin	2
29	ST160F--1110104	Governor shaft	1
30	ST160F--1110103	Governor holder clip	1
31	ST160F--1110107	Governor weight	2
32	ST168F-1126000	relay	1
33	ST160F--1110105-A	Governor cover	1
34	ST168FD-2-1050001-A	Crankshaft comp	1
35	ST168F-1030008-G	Case over packing no asbestos)	1
36	ST160F--1030001-B	Oil filler cap assembly	1
37	ST160F--1030002	Oil filler cap packing	2
38	GB5789--86-FB8-32	Flange bolt 8*32	6
39	ST168F--1110005	Throttle return spring	1
40	ST168F--1110007	Governor spring	1
41	ST160F--1110003	Governor arm	1
42	GB6177--86	Nut M6	3
43	ST160F--1110008	Lock pin	1
44	ST160F--1110001	Governor arm shaft	1
45	ST168F--1110006	Governor rod	1
46	ST160F--1110004	Governor arm bolt	1
47	GB5789--86-FB6-25	Flange bolt 6*25	5
48	ST160F--1123000-G	ignition	1
49	152FMD--1001007	Dowel pin 10*16	2
50	GB5789--86-FB8-55	Flange bolt 8*55	4
51	ST168FD--1090200-G	Air cleaner cover comp	1
52	ST168FD--1090004	Element	1
53	ST168FD--1090003	Separator	1
54	ST168FD--1090002	Air cleaner seal	1
55	ST168FD-1091000-G	Air cleaner case comp	1
56	ST160F--1130003-CPE	Carburetor packing no asbestos)	1
57	ST168F--1130001	Carburetor insulator	1
58	ST168F--1130002-CPE	Insulator packing no asbestos)	1

#	Part Number	Description	Qty
59	ST160F--1010001	Stud bolt 6*110	2
60	ST168F-2-1010100-G	Cylinder head comp	1
61	ST168F-2-1030009-G	Cylinder head gasket	1
62	ST168F--1040002	Intake valve	1
63	ST168F--1040006	Exhaust valve	1
64	ST168F-2-1040013	Valve lifter	2
65	ST168F-2-1041000	Camshaft assembly	1
66	ST168F--1030015-G	Dowel pin 9*14	2
67	ST168FD--1111100	Control assy	1
68	GB1099--79	Key	1
69	ST168FD--1030007-G	Crankcase cover	1
70	ST168F--1050100	Connecting rod comp	1
71	ST168F--1050003	Piston pin	1
72	ST168F--1050004	Piston pin clip	2
73	ST168F-2-1050005	Piston	1
74	ST168F--1050007	First ring set	1
	ST168F--1050006	Second ring set	1
	ST168F--1050200	Ring comp	1
75	ST168F--1080002-G	Shroud comp (I)	1
76	GB900--88	Stud bolt	2
77	ST168F--1040005	Push rod	2
78	ST168-1040014-A	oil seal	2
79	ST168F--1040027	Pivot bolt	2
80	ST168F--1040026	Valve rocker arm	1
81	GB6177--86-N6	nut M6	2
82	ST168F--1040023	exhaust rocker	1
83	ST160F--1020001	Breather tube	1
84	ST168F--1020100-C	Head over comp	1
85	ST160F--1020002-A	Head over packing	1
86	ST168F--1040024	rectify bolt	2
87	ST168F--1040025	locknut	2
88	ST168F--1040022	entrance rocker	1
89	ST168F--1040021	rocker axes	1
90	ST160F--1040008	Valve rotator	1
91	ST160F--1040001	Intake valve spring retainer	1
92	ST160F--1040007	Exhaust valve spring retainer	1
93	ST160F--1040003	Valve spring	2
94	ST160F--1124000	Spark plug	1
95	ST168FD-2-1131000	Carburetor	1
96	ST168FD--1130005-CPE	Packing	1
97	ST02FD-1151201A	Choke lever comp	1
98	ST188F-1123000	Electrify coil	1
99	ST168F-1180104	Grommet	1
100	ST168F-1180002	Wire flat	1
101	GB5789--86-FB6-29	Flange bolt 6*29	1
102	ST168F-1180001	Dowel pin 8x10	2
103	ST168F-1181100	Start motor	1
104	GB29.2-88-FB5-16	Flange boltM5x16	2
	GB93-87-SW5	Spring washer 5	2

SPECIFICATIONS

Wiring Diagram

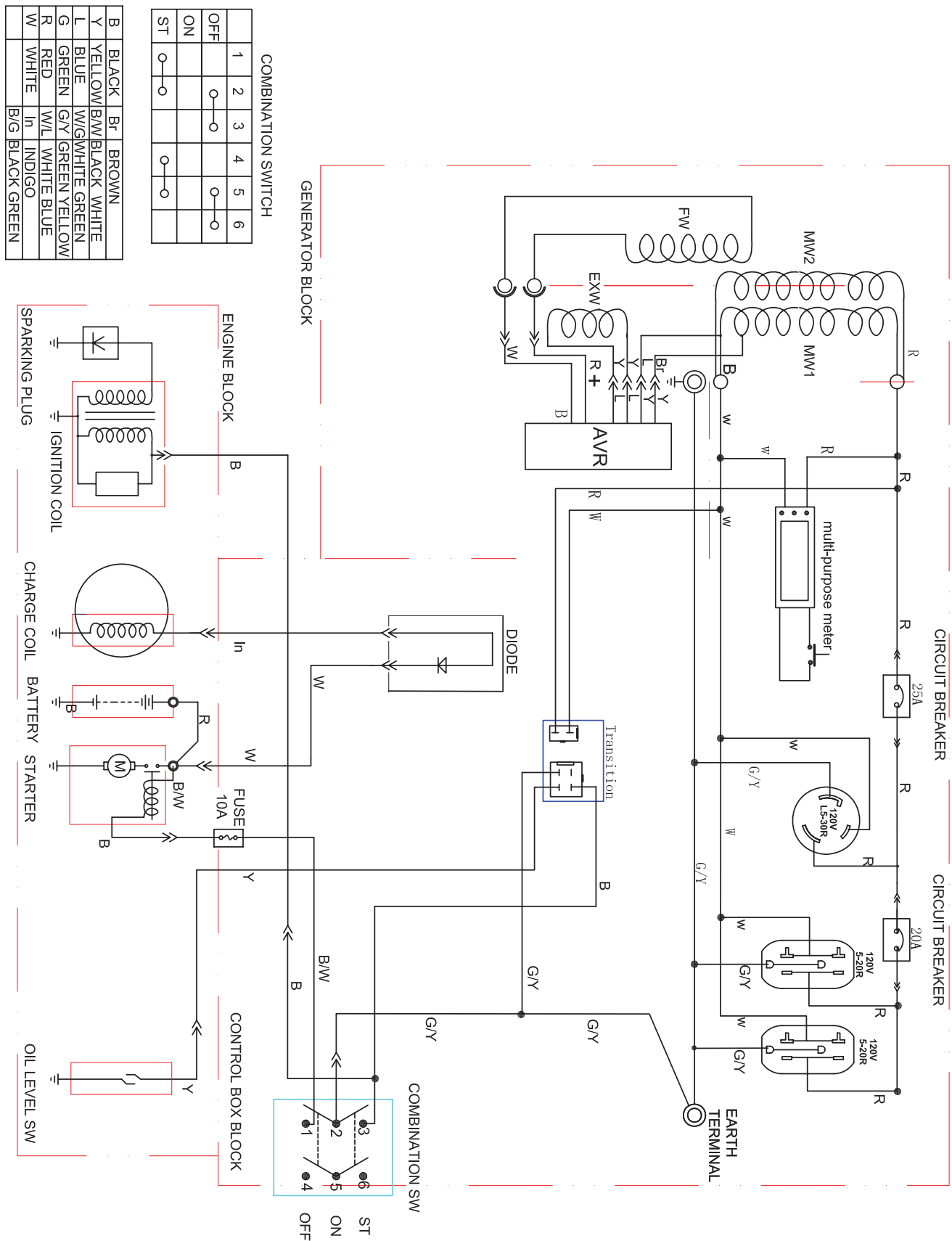

Problem	Cause	Solution
Generator will not start	No fuel	Add fuel
	Faulty spark plug	Replace spark plug
	Unit loaded during start up	Remove load from unit
Generator will not start;	Low oil level	Fill crankcase to the proper level
		Place generator on a flat, level surface
Generator starts but runs roughly	Choke in the wrong position.	Adjust choke.
	Spark plug wire loose	Attach wire to spark plug
Generator shuts down during operation	Out of fuel	Fill fuel tank
	Low oil level	Fill crankcase to the proper level. Place generator on a flat, level surface
Generator cannot supply enough power or overheating	Generator is overloaded	Review load and adjust. See "Power Management"
	Insufficient ventilation	Check for air restriction. Move to a well ventilated area
No AC output	Cable not properly connected	Check all connections
	Connected device is defective	Replace defective device
	Circuit breaker is open	Reset circuit breaker
	Faulty brush assembly	Replace brush assembly (Service Center)
	Faulty AVR (auto voltage regulator)	Replace AVR (Service Center)
	Loose wiring	Inspect and tighten wiring connections
Generator gallops	Engine governor defective	Contact the help line
	Other	Contact the help line.
Repeated circuit breaker tripping	Overload	Review load and adjust. See "Power Management"
	Faulty cords or device	Check for damaged, bare or frayed wires. Replace defective device

For further technical support:

Technical Service

Mon – Fri 8:30 AM – 5:00 PM (PST/PDT)

Toll Free: 1 (877) 338-0999

tech@championpowerequipment.com

WARRANTY

WARRANTY

CHAMPION POWER EQUIPMENT
2 YEAR LIMITED WARRANTY

Warranty Qualifications

Champion Power Equipment (CPE) will register this warranty upon receipt of your Warranty Registration Card and a copy of your sales receipt from one of CPE's retail locations as proof of purchase.

Please submit your warranty registration and your proof of purchase within ten (10) days of the date of purchase.

Repair/Replacement Warranty

CPE warrants to the original purchaser that the mechanical and electrical components will be free of defects in material and workmanship for a period of one year (parts and labor) and two years (parts) from the original date of purchase (90 days (parts and labor) and 180 days (parts) for commercial & industrial use). Transportation charges on product submitted for repair or replacement under this warranty are the sole responsibility of the purchaser. This warranty only applies to the original purchaser and is not transferable.

Do Not Return The Unit To The Place Of Purchase

Contact CPE's Technical Service and CPE will troubleshoot any issue via phone or e-mail. If the problem is not corrected by this method, CPE will, at its option, authorize evaluation, repair or replacement of the defective part or component at a CPE Service Center. CPE will provide you with a case number for warranty service. Please keep it for future reference. Repairs or replacements without prior authorization, or at an unauthorized repair facility, will not be covered by this warranty.

Warranty Exclusions

This warranty does not cover the following repairs and equipment:

Normal Wear

Generators need periodic parts and service to perform well. This warranty does not cover repair when normal use has exhausted the life of a part or the equipment as a whole.

Installation, Use and Maintenance

This warranty will not apply to parts and/or labor if this generator is deemed to have been misused, neglected, involved in an accident, abused, loaded beyond the generator's limits, modified, installed improperly or connected incorrectly to any electrical component.

Installation, Use and Maintenance Cont'd.

Normal maintenance such as spark plugs, air filters, adjustments, fuel system cleaning and obstruction due to buildup is not covered by this warranty.

Other Exclusions

This warranty excludes:

- Cosmetic defects such as paint, decals, etc.
- Wear items such as filter elements, o-rings, etc.
- Accessory parts such as starting batteries, and storage covers.
- Failures due to acts of God and other force majeure events beyond the manufacturer's control.
- Problems caused by parts that are not original Champion Power Equipment parts.

This warranty does not apply to generators used for prime power in place of a utility.

Limits of Implied Warranty and Consequential Damage

Champion Power Equipment disclaims any obligation to cover any loss of time, use of this product, freight, or any incidental or consequential claim by anyone from using this generator. THIS WARRANTY IS IN LIEU OF ALL OTHER WARRANTIES, EXPRESS OR IMPLIED, INCLUDING WARRANTIES OF MERCHANTABILITY OR FITNESS FOR A PARTICULAR PURPOSE.

A unit provided as an exchange will be subject to the warranty of the original unit. The length of the warranty governing the exchanged unit will remain calculated by reference to the purchase date of the original unit.

This warranty gives you certain legal rights which may change from state to state. Your state may also have other rights you may be entitled to that are not listed within this warranty.

Contact Information

Address

Champion Power Equipment, Inc.
Customer Service
10006 Santa Fe Springs Rd.
Santa Fe Springs, CA 90670
www.championpowerequipment.com

Customer Service

Mon – Fri 8:30 AM – 5:00 PM (PST/PDT)
Toll Free: 1 (877) 338-0999
Fax no.: 1 (562) 236-9429

Technical Service

Mon – Fri 8:30 AM – 5:00 PM (PST/PDT)
Toll Free: 1 (877) 338-0999
tech@championpowerequipment.com

**Champion Power Equipment, Inc (CPE),
Emission Control System Warranty**

Your Champion Power Equipment (CPE) engine complies with Environment Canada (EC) emission regulations.

YOUR WARRANTY RIGHTS AND OBLIGATIONS:

CPE is pleased to explain the Emission Control Systems Warranty on your 2011 small off-road engine. New engines must be designed, built and equipped, at the time of sale, to meet EC regulations for small non-road engines. CPE must warrant the emission control system on your small off-road engine for the period of time listed below, provided there has been no abuse, neglect, unapproved modification, or improper maintenance of your small off-road engine.

Your emission control system may include parts such as the carburetor, fuel-injection system, the ignition system, catalytic converter and fuel lines. Also included may be hoses, belts, connectors and other emission related assemblies. Where a warrantable condition exists, CPE will repair your small off-road engine at no cost to you including diagnosis, parts and labor.

MANUFACTURER'S EMISSION CONTROL SYSTEM WARRANTY COVERAGE:

This emission control system is warranted for two years, subject to provisions set forth below. If, during the warranty period, emission related part on your engine is defective in materials or workmanship, the part will be repaired or replaced by CPE.

OWNER WARRANTY RESPONSIBILITIES:

As the small off-road engine owner, you are responsible for the performance of the required maintenance listed in your Owner's Manual. CPE recommends that you retain all your receipts covering maintenance on your small off-road engine, but CPE cannot deny warranty solely for the lack of receipts or for your failure to ensure the performance of all scheduled maintenance.

As the small off-road engine owner, you should however be aware that CPE may deny you warranty coverage if your small, off-road engine or a part has failed due to abuse, neglect, improper maintenance or unapproved modifications.

You are responsible for presenting your small off-road engine to an Authorized CPE service outlet, CPE dealer or CPE, Santa Fe Springs, CA., USA as soon as a problem exists. The warranty repairs should be completed in a reasonable amount of time, not to exceed 30 days.

If you have any questions regarding your warranty rights and responsibilities, you should contact:

Champion Power Equipment, Inc.
Customer Service
10006 Santa Fe Springs Road
Santa Fe Springs, CA 90670
USA
Tel: 1-877-338-0999

The emission warranty is a defects warranty. Defects are judged on normal engine performance. The warranty is not related to an in-use emission test.

EMISSION CONTROL SYSTEM WARRANTY

The following are specific provisions relative to your Emission Control System Warranty Coverage.

Emission Control System Warranty (ECS Warranty):

1. APPLICABILITY: The ECS Warranty Period shall begin on the date the new engine or equipment is delivered to its original, end-use purchaser, and shall continue for 24 consecutive months thereafter.

2. GENERAL EMISSIONS WARRANTY COVERAGE

CPE warrants to the original, end-use purchaser of the new engine or equipment and to each subsequent purchaser that each of its small off-road engines is:

- a. Designed, built and equipped so as to conform at the time of sale with applicable regulations under the Canadian Environmental Protection Act, 1999 (CEPA 1999).
- b. Free from defects in materials and workmanship that cause the failure of a warranted part to be identical in all material respects to the part as described in the engine manufacturer's application for certification for a period of two years.

3. THE WARRANTY ON EMISSION-RELATED PARTS WILL BE INTERPRETED AS FOLLOWS:

a. Any warranted part that is not scheduled for replacement as required maintenance in the Owners Manual shall be warranted for the ECS Warranty Period. If any such part fails during the ECS Warranty Period, it shall be repaired or replaced by CPE according to Subsection "d" below. Any such part repaired or replaced under the ECS Warranty shall be warranted for any remainder of the ECS Warranty Period.

b. Any warranted, emissions-related part which is scheduled only for regular inspection as specified in the Owners Manual shall be warranted for the ECS Warranty Period. A statement in such written instructions to the effect of "repair or replace as necessary", shall not reduce the ECS Warranty Period. Any such part repaired or replaced under the ECS Warranty shall be warranted for the remainder of the ECS Warranty Period.

c. Any warranted, emissions-related part which is scheduled for replacement as required maintenance in the Owner's Manual shall be warranted for the period of time prior to the first scheduled replacement point for that part. If the part fails prior to the first scheduled replacement, the part shall be repaired or replaced by CPE according to Subsection "d" below. Any such emissions-related part repaired or replaced under the ECS Warranty, shall be warranted for the remainder of the ECS Warranty Period prior to the first scheduled replacement point for such emissions-related part.

d. Repair or replacement of any warranted, emissions-related part under this ECS Warranty shall be performed at no charge to the owner at a CPE Authorized Service Outlet.

e. The owner shall not be charged for diagnostic labor which leads to the determination that a part covered by the ECS Warranty is in fact defective, provided that such diagnostic work is performed at a CPE Authorized Service Outlet.

f. CPE shall be liable for damages to other original engine components or approved modifications proximately caused by a failure under warranty of an emission-related part covered by the ECS Warranty.

g. Throughout the ECS Warranty Period, CPE shall maintain a supply of warranted emission-related parts sufficient to meet the expected demand for such emission-related parts.

h. Any CPE Authorized and approved emission-related replacement part may be used in the performance of any ECS Warranty maintenance or repair and will be provided without charge to the owner. Such use shall not reduce CPE's warranty obligation.

i. Unapproved add-on or modified parts may not be used to modify or repair a CPE engine. Such use voids this ECS Warranty and shall be sufficient grounds for disallowing an ECS Warranty claim. CPE shall not be liable hereunder for failures of any warranted parts of a CPE engine caused by the use of such an unapproved add-on or modified part.

EMISSION-RELATED PARTS INCLUDE THE FOLLOWING: (using those portions of the list applicable to the engine)

Systems covered by this warranty	Parts Description
Fuel Metering System	Fuel regulator, Carburetor and internal parts
Air Induction System	Air cleaner, Intake manifold
Ignition System	Spark plug and parts, Magneto ignition system
Exhaust System	Exhaust manifold, catalytic converter
Miscellaneous Parts	Tubing, Fittings, Seals, Gaskets, and Clamps associated with these listed systems.

TO OBTAIN WARRANTY SERVICE:

You must take your CPE engine or the product on which it is installed, along with your warranty registration card or other proof of original purchase date, at your expense, to any Champion Power Equipment dealer who is authorized by Champion Power Equipment, Inc. to sell and service that CPE product during his normal business hours. Claims for repair or adjustment found to be caused solely by defects in material or workmanship will not be denied because the engine was not properly maintained and used.

If you have any questions regarding your warranty rights and responsibilities, or to obtain warranty service, please write or call Customer Service at Champion Power Equipment, Inc.

**Champion Power Equipment, Inc.
10006 Santa Fe Springs Road
Santa Fe Springs, CA 90670
USA
1-877-338-0999
Attn: Customer Service**